



**PPU** College of  
Engineering and Technology

The Home of Competent Engineers and Researchers

**Electrical and Computer Engineering Department**

**Industrial Automation and Biomedical  
Engineering Program**

**Bachelor Thesis**

**Graduation Project**

**Lower Limb Rehabilitation System After Stroke And Spinal  
Cord Injury**

**Project Team**

**Nidal M. Shahateet**

**Ayed Z. Zahran**

**Abd Alfatah Botma**

**Project Supervisor**

**Eng. Nassim Iqteit**

**Hebron – Palestine**

**2011 – 2012**

## **DEDICATION**

This project is for our magnified martyrs who  
sacrificed their selves for the sake of liberated  
Palestine and Jerusalem

To my parents who dedicated their lives for me and  
for my brother as well

To my lectures who have done their best to the  
whole generations

And to the supervisor and lecture Nassim Iqteit

**Work Team**

## الإهداء

إلى فلسطين الحبيبة ..... إلى فلسطين الجريحة ..... إلى فلسطين الحرة الأبية .... إلى القدس عاصمة الدولة  
الفلسطينية .....

إلى من ضحوا بأرواحهم في سبيل الله والوطن ..... إلى شهدائنا الأبرار  
إلى أبطال الحرية إلى رموز الأمعاء الخاوية ..... إلى أسرانا البواسل

إلى النور الذي يُنيرُ لي درب النجاح ..... إلى من علّمني معنى العلم ..... إلى من علّمني الصمودَ مهما تبدلت  
الظروف..... \*\*\* إلى أبي العزيز \*\*\*

إلى من تتسابقُ الكلماتُ لتخرجَ مُعبِرةً عن مكنون ذاتِها ..... إلى من دودتني بالحنان والمحبة ..... إلى من  
سهرت الليالي لراحتي ..... إلى من لم تألُ جهداً في تربيّتي وتنقيفي .....  
\*\*\* إلى أمي الحبيبة \*\*\*

إلى من أضاء لي الطريق ..... إلى من قادني إلى النجاح .... إلى من لا أكونَ بدونهم ..... إلى من رخصت  
لهمُ الحياة .....  
إلى أخوتي الأعزاء .....

إلى من كان لي الأخ .... إلى من شاركني فرحي وقاسمني حزني ..... إلى أصدقائي الأعزاء ....

إلى من تتحنني لهم الرؤوس احتراماً وتقديراً ..... إلى من أضاء بعلمه عقل غيره .... إلى أساتذتي الأفاضل

إلى من هدى بالجواب الصحيح حيرةً سائلة ... فأظهر بسماعته تواضع العلماء وبرحابته سماحة العارفين ...  
إلى مشرف هذا العمل .... إلى من كان لنا الأخ والصديق ..... المهندس نسيم اقطيط

..... نهدي لهم ثمار اجتهادنا.....

فريق العمل

## **ACKNOWLEDGMENT**

We like to express our thank and gratitude to Allah, the most beneficent, the most merciful who granted us the ability and willing to start and completed this research.

We wish express our deep and sincere thank and gratitude to Palestine Polytechnic University, the Department of Electrical and Computer Engineering, College of Engineering and Technology.

We wish to express our Thank and gratitude to Eng. Nassim Iqteit, for available help, encouragement, supervision and guidance in solving the problem that we face from time to time during this research.

**Work Team**

## شكر وتقدير

نتوجه بالشكر والامتنان إلى الله الرحمن الرحيم ، الذي منحنا القدرة على إتمام هذا العمل.. .. ف سبحانه الله العظيم عدد خلقه و زنة عرشه..

كما و نتوجه بالشكر الجزيل مع فائق الاحترام لجامعة بوليتكنك فلسطين، لدائرة الهندسة الكهربائية والحاسوب، لكلية الهندسة والتكنولوجيا..... .

ولن ننسى أيضا أن نتوجه بالشكر والعرفان للمهندس نسيم اقطيط، مشرف العمل لما قدم لنا من مساعدة وإشراف وتشجيع وتوجيهنا لحل المشاكل المعترضة من وقتٍ لآخر .. .. .

وإلى كل من المستشفى الأهلي والجمعية العربية للتأهيل وجمعية الإحسان ومركز الورود للعلاج الطبيعي

....والى كل من ساهم في إنجاز هذا العمل ...

فريق العمل

## ABSTRACT

### "System of rehabilitation of the lower limbs post-stroke and spinal cord injury"

By

**Nidal M. Shahateet**

**Ayed Z. Zahran**

**Abed Alfatah Botma**

**Palestine Polytechnic University**

**S**troke is Classified as the third cause of death in the world, as every four minutes a person is infected with stroke in the world .The treatment of patients with stroke by giving him a Anti blood clotting to prevent the occurrence of stroke again , Where a high percentage of physical therapy in the treatment of patients , Where the ratio is about 80 % .

The walking stage is the most important stage of physiotherapy of the lower limbs in cases of paralysis resulting from stroke or spinal cord injuries resulting from several factors such as traffic accidents or incidents falling , As the lower limbs is one of the most important organs in the human body because they help him to do everyday tasks , walking and training Help the muscles to stimulate the nerve centers in the lower limbs . From here show the importance of system rehabilitation of lower limbs after injury, stroke and spinal cord injuries .

From here show the importance of *lower limb rehabilitation system after stroke and spinal cord injury* post-stroke and spinal cord injuries, Which is based on maintaining the balance of the patient and assist in the process of walking and to reduce the weight of his body so he Able to walk on his feet , and move easily Because the patient has Paraplegic or total paralysis., It also helps the therapist during the treatment process, as it eases the burden of carrying the weight of the patient during the lift and hold it and help him walk.

Rehabilitation system is divided into two parts : the first – "a walking Treadmill" , the second "Body weight support (BWS)", where the system helps the patient to walk easily and safely , And generate a sense of relief to the patient.

The system is also equipped with instruments that medical help in improving the level of treatment planning, such as a muscle "EMG" and a stimulating muscles in the idle state (inability to move) , and heart rate , which helps in monitoring the condition of the patient during the process of walking.

# بسم الله الرحمن الرحيم

## الملخص

" نظام إعادة تأهيل الأطراف السفلية ما بعد الجلطة الدماغية وإصابات الحبل الشوكي "

إعداد

عائد زايد زهران

نضال محمود شحاتيت

عبد الفتاح بطمة

جامعة بوليتكنك فلسطين

تصنف الجلطة الدماغية كثالث مرض مسبب للوفاة على مستوى العالم، حيث أن كل أربعة دقائق يصاب شخص بالجلطة الدماغية في العالم. ويتمثل علاج المريض بإعطائه جرعات من مميعات الدم المانعة للتخثر وذلك للوقاية في ما بعد الجلطة حيث يمثل العلاج الطبيعي ما يقارب 80% من العلاج في حالات الجلطة الدماغية .

وتعتبر مرحلة المشي من أهم مراحل العلاج الطبيعي للإطراف السفلية في حالات الشلل الناتجة من الجلطة الدماغية أو إصابات الحبل الشوكي الناتجة من عدة عوامل مثل حوادث السير أو حوادث السقوط وذلك لاعتبار الأطراف السفلية من أهم الأطراف من الناحية الوظيفية في جسم الإنسان وذلك لأنها تساعد بدرجة كبيرة للقيام بمهامه اليومية الضرورية، عوضاً عن وجود مراكز عصبية في الأطراف السفلية والتي ومن خلال المشي تساعد على تحفيز ونشيط خلايا الدماغ التالفة .

من هنا تظهر أهمية نظام إعادة تأهيل الأطراف السفلية ما بعد الجلطة الدماغية وإصابات الحبل الشوكي، والذي يقوم على أساس مسك المريض ومساعدته في عملية المشي وتخفيف وزن جسمه ليستطيع الضغط على أقدامه وتحريكهما بسهولة لكونهما مصابتان بالشلل الكلي أو النصفى. كما يساعد هذا النظام أخصائي العلاج الطبيعي أثناء عملية العلاج، حيث يخفف عنه عبئ تحمل وزن المريض أثناء رفعه ومسكه ومساعدته في المشي.

ينقسم نظام إعادة التأهيل إلى قسمين رئيسيين : الأول- نظام المشي " Treadmill " ، الثاني – نظام دعم وزن الجسم " Body weight support (BWS) " ، حيث يساعد نظام الركض المريض على المشي بسهولة وأمان وهو في مكانه كما يساهم نظام دعم وزن الجسم بتوفير الحماية والأمان للمريض وتحمل جزء من وزنه أثناء عملية المشي وتوليد الشعور بالراحة لدى المريض.

كما أن النظام مزود بأدوات طبية تساعد في تحسين مستوى العلاج مثل جهاز تخطيط العضلات " EMG " وجهاز تحفيز العضلات في حالة الخمول الوظيفي وجهاز قياس نبض القلب الذي يساعد في عملية مراقبة حالة المريض أثناء عملية المشي.

## LISTE OF FIGUERS

<b>Fig. No.</b>	<b>Description</b>	<b>Page No.</b>
Fig.(1-1)	Novel Mechatronic	3
Fig.(1-2)	Force and Torque	4
Fig.(1-3)	Equivalent mechanical parts of human body	5
Fig.(1-4)	Equivalent mechanical parts of human body	5
Fig.(1-5)	BWS System	7
Fig.(1-6)	Motor unit	10
Fig.(1-7)	physiological processes	11
Fig.(2-1)	two main types of stroke	15
Fig.(3-1)	Over all structure	19
Fig.(3-2)	Profile rods	20
Fig.(3-3)	Profile rods	20
Fig.(3-4)	Side Handle	20
Fig.(3-5)	overall structure	21
Fig.(3-6)	The over all structure	22
Fig.(3-7)	treadmill structure	23
Fig.(3-8)	Treadmill	24
Fig.(3-9)	PM-DC motor	25
Fig.(3-10)	timing gear	26
Fig.(3-11)	walking belt	26
Fig.(3-12)	rear roller	27
Fig.(3-13)	active BWS system	28
Fig.(3-14)	Pulley System	29
Fig.(3-15)	BWS System	30
Fig.(3-16)	Induction motor	31
Fig.(3-17)	converting 3phase induction motor to 1 phas	31
Fig.(3-18)	electrical break	33
Fig.(3-19)	Winch Drum	33
Fig.(3-20)	Position sensor	34
Fig.(3-21)	Tension Sensor	35
Fig.(3-22)	Accelerometer	36
Fig.(3-23)	load cell	36
Fig.(3-24)	Magnetic encoder	37
Fig.(3-25)	BWS load	37
Fig.(3-26)	pulley	38
Fig.(3-27)	System Flow Chart	40
Fig.(3-28)	Block diagram of EMG	41
Fig.(3-29)	Electrodes Placements Sites	42
Fig.(3-30)	EMG circuit	43
Fig.(3-31)	control circuit	43
Fig.(3-32)	EMG circuit	44
Fig.(3-33)	AD620	44
Fig.(3-34)	HPF	45
Fig.(3-35)	Inverting amplifier	46

Fig.(3-36)	The 555 timer Monostable Circuit	47
Fig.(3-37)	NPN transistor	47
Fig.(3-38)	Wave Form of The Output Signal	48
Fig.(3-39)	Block diagram of EMS	48
Fig.(3-40)	Circuit of The EMS	49
Fig.(3-41)	EMS circuit	50
Fig.(3-42)	Wave Form of The Output Signal	51
Fig.(3-43)	Pre-gelled electrode	52
Fig.(3-44)	Block diagram of heart rate	53
Fig.(3-45)	photocell transmitter and received sensor	53
Fig.(3-46)	chopper circuit	54
Fig.(3-47)	chopper circuit	55
Fig.(3-48)	Chopper output voltage	56
Fig.(3-49)	AC –DC converter	57
Fig.(3-50)	DC-DC convertor	58
Fig.(3-51)	MOSFET	58
Fig.(3-52)	Virstor	59
Fig.(3-53)	freewheeling Diode	60
Fig.(3-54)	PID controller	61
Fig.(3-55)	motor output voltage	62
Fig.(3-56)	3-ph squirrel cage IM	63
Fig.(3-57)	control panel	65
Fig.(3-58)	control panel	66
Fig.(3-59)	Explanation of connecting external systems with control panel.	67
Fig.(3-60)	switching on / off control panel	68
Fig.(3-61)	PLC connection	69
Fig.(3-62)	PLC	70
Fig.(3-63)	primary power circuit	71
Fig.(3-64)	DC power supply circuit	72
Fig.(3-65)	program Logo	73
Fig.(3-66)	flowcode the PWM	74
Fig.(3-67)	Kit K150	75
Fig.(3-68)	Touch screen	76
Fig.(3-69)	Example of reversing induction motor	77
Fig.(3-70)	Example of touch screen program	77
Fig.(3-71)	PLC program	78
Fig.(3-72)	priority triangle	79

## LISTE OF TABLES

<b>Table No.</b>	<b>Description</b>	<b>Page No.</b>
Table.(1-1)	Project Cost	13
Table(3-1)	PM DC motor name plate	25
Table.(3-2)	IM name plate	32
Table.(3-2)	Winch drum dimention	33

## LISTE OF EQUATIONS

<b>Fig. No.</b>	<b>Description</b>	<b>Page No.</b>
Eq.(3-1)	Force Equation	38
Eq.(3-2)	Force Equation	38
Eq.(3-3)	Load Torque Equation	38
Eq.(3-4)	Output torque Equation	39
Eq.(3-5)	Critical frequency Equation	45
Eq.(3-6)	Time equation for timer 555	47
Eq.(3-7)	Frequency for timer 555	50
Eq.(3-8)	Duty cycle	55
Eq.(3-9)	Peak Voltage	56
Eq.(3-10)	Peak Current	56
Eq.(3-11)	Capacitance	58

## TABLE OF CONTENTS

Subject	Page
Title	
Description	
Knowledge	
Abstract	
List of Figure	
List of Table	
Table of Contents	
<hr/>	
<b>CH.1 INTRODUCTION</b>	<b>Page</b>
<hr/>	
1.1- General Background	2
1.2- Project Aims	2
1.3- Literature Review	3
1.4- Project Description	8
1.5- Project Parts	13
1.6- Project Cost	13
<hr/>	
<b>CH.2 REHABILITATION AND DISEASE</b>	<b>Page</b>
<hr/>	
2.1- Stroke	15
2.2- A Spinal Cord Injury	16
2.3- Rehabilitation	16
2.4- Physiology Physiotherapist	17
<hr/>	
<b>CH.3 ELECTRICAL AND MECHNICAL DESIGN</b>	<b>Page</b>
<hr/>	
3.1- Introduction	19
3.2- Overall Structure	19
3.3- Treadmill	22
3.4- Body Weight Support "BWS" System	27
3.5- System Flow Chart	39
3.6- Biomedical Part Design	41
3.7- The Automation Part	54

---

3.8- Software	73
3.9- Safety and Protection	79

---

#### CH.4 SUMMARY

---

---

4.1 Marketing	82
4.2 Conclusion	82
4.3 Recommendations	82

---

---

REFERENCES	84
------------	----

APPENDIX A .Table of standard

APPENDIX B . Datasheet

# CHAPTER "1"

## INTRODUCTION

---

- 1.1- General Background
- 1.2- Project Aims
- 1.3- Literature Review
- 1.4- Project Description
- 1.5- Project Parts
- 1.6- Project Cost

## **1.1 General Background :**

Stroke is the third most frequent cause of death worldwide and the leading cause of permanent disability [1] , Every 4- minutes someone dies in the world of stroke [2].

Stroke is sometimes called a “brain attack.” A stroke injures the brain like a heart attack injures the heart. A stroke occurs when a part of the brain doesn't get the blood it needs. Strokes in the brain stem are very harmful because the brain stem controls all our body's functions that we don't have to think about, such as eye movements, breathing, hearing, speech, and swallowing. Since impulses that start in the brain must travel through the brain stem on their way to the arms and legs, patients with a brain stem stroke may also develop paralysis, or not be able to move or feel on one or both sides of the body. In many cases, a stroke weakens the muscles, and makes it hard to walk, eat, or dress without help. Some symptoms may improve with time and rehabilitation or therapy.[3] Restoration of walking ability is the major goal in the rehabilitation of patients with acquired brain damage "Stroke" and after spinal cord injury. Accordingly, the primary goal of therapeutic efforts should be to restore independent walking ability [4].

Therefore, Rehabilitation stage is the most important stages during the treatment period. Lower Limb Rehabilitation System is the system that help the patient and Physiotherapist during the treatment period Through providing the safety to the patient and the physiotherapist from the electrical and mechanical system can be used . This system consists of many parts to help the patient in walking and moving their legs and provide a comfort ability through treatment period. Treadmill system provides moving up ground for the walking, and the "Lokolift" weight support system "BWS" can be reduces the load that is needed to be overcome by the patient and facilitate stepping movements. In addition, the BWS system ensures safety and stability of the patient walking on the treadmill.

## **1.2 Project Aims :**

The idea of the study comes from the suffering of the patients with stroke and spinal cord injury , the suffering endured by the physical therapist and the parent of patient and the length of treatment period, especially with the small number of specialists in this field of physical therapy, for that the project tries to achieve the following objective :

- 1- To help the patient at the process of walking and provide him safety and correct position while walking.
- 2- To save time, effort and material cost in the rehabilitation of stroke and spinal cord injuries.
- 3- To ensure the protection for the specialist from the diseases during the treatment process, such as slipped discs.
- 4- To Provide safety and security of the patient from common errors committed by Physiotherapist
- 5- To stimulate the muscle movement and Increase the patient's ability to do moving activities .
- 6- To improve the level of treatment, especially on the level of Palestine.



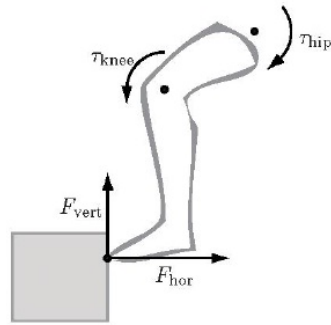

Fig.(1-2) Force and Torque

- 3- a paper describes the control strategy for an active body suspension system for treadmill based neural rehabilitation or training devices. And analysis the equivalent mechanical parts Which to human body, Fig.(1-3) [9] .

Results:

Reduced the dynamic load on the trainee's for supporting leg or legs depending on whether one or two feet touching the ground in the exercise simulation results demonstrated the effectiveness of the active system in comparison with the corresponding reduced mass system and a passive counter-weight balance system.

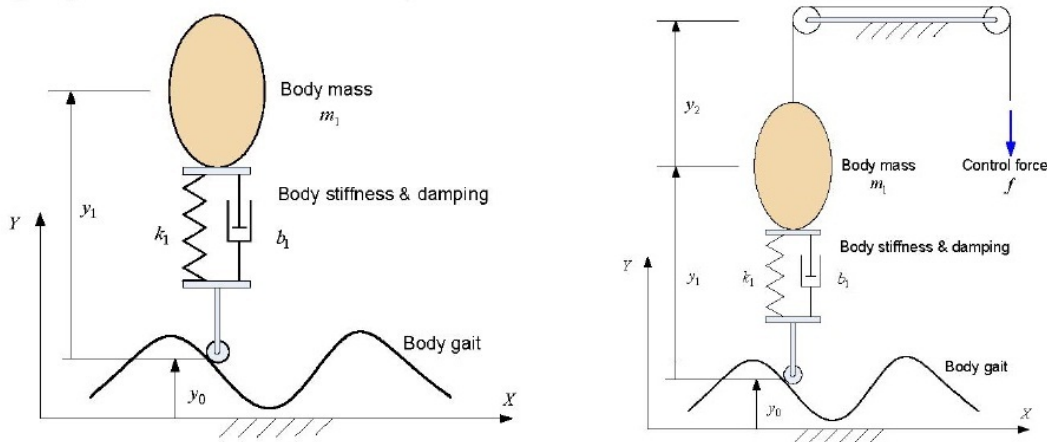

Fig.(1-3) passive counter-weight balance system.

- 4- paper reports on the main characteristics and results to the gain understanding in the current status of Robotics in healthcare [10] .

Results:

Since the overall sector of robotics in healthcare is still an emerging area with successes and failures, a final conclusion about the future trajectory cannot be made at present.

More than the development of new applications, the field also needs the further enhancement of the "Robotics for Healthcare" network to establish a sound multidisciplinary community. Researchers, industry, medical professionals and users themselves should all be included to enhance user oriented research. The fact that there is already a network will be helpful in this.

- The field is still in its infancy, but some products are already commercialised. This supports the conclusion that there is a market, but that this market has just entered its growth phase. It will take a lot of time before important innovations find their way into regular healthcare. Some ideas will not even be realised within the study's time horizon of 2025.

- Because the field is very new, acceptance and implementation will be complicated. To raise awareness and promote involvement of stakeholders, awareness activities should accompany any innovation program.

5- The aim of one study was to understand and measure the lower limbs muscular activation patterns both in healthy and spinal cord injured (SCI) subjects during robot assisted locomotor exercise [11] .

#### Results:

After the rehabilitation robot-assisted treatment, the SCI patients analyzed in this study show an increased bilateral muscular activity. Improvements in their locomotion function were observed, as well. These results provide evidence in support of the benefic patient-robot interaction.

For each subject, the proposed analysis lets to identify (1) which muscles require additional rehabilitation treatment and (2) the optimal conditions of the training. Such approach may lead to a personalization of the treatment, adjusting the percentage of BWS, treadmill speed and modality of cooperation, according to the changes occurring during the motor recovery of each subject.

6- paper describes the EMG pattern variations of Gastrocnemius and Soleus muscles with the help of surface EMG. The EMG is classified on the basis of RMS amplitude values and frequency analysis [12] .

#### Results:

The variation in amplitude and median frequency of EMG signal can be used to identify the speed of walk of a normal human .

7- This paper presents a novel active body weight support (BWS) method, which is capable of virtually offloading full or partial body mass for a potential application of enhancing treadmill-based locomotion rehabilitation [13] .

Results:

In the simulation study, the mass-offload BWS system including the attached human body was modeled as a multi body dynamical system. Thus, it can make the attached human feel exactly as if he/she had a reduced body mass.

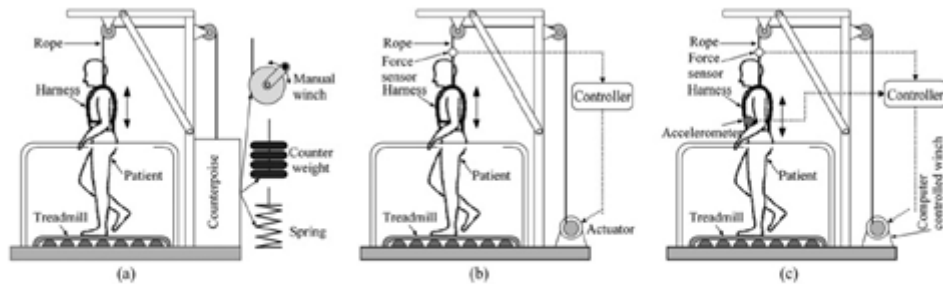

BWS systems for treadmill-based locomotion training. (a) A passive BWS. (b) An existing active weight-off load BWS. (c) The proposed mass-offload BWS.

Fig.(1-5) BWS System

8- a new type of gait rehabilitation training robot system driven by pneumatic actuators is designed, which can guide the patient legs to move in a preprogrammed gait pattern on the special treadmill [14] .

Results:

The gait rehabilitation trammg robot system driven by pneumatic actuators has good flexibility and security .In the next step we will focus on perfecting the prototype, expanding and optimizing the function of the system, studying and assessing the effect of rehabilitation in the clinical trial and so on.

## 1.4 Project Description

### General Description :

As a solution of losing the ability of walking that was caused by a stroke we propose a mechanism to help the patients to retain their ability to walk as possible . This mechanism consists of a structure and a robe handle from the top of the structure that fix the patient in a vertical position .The length of the robe can be adjusted with an electrical winch to adapt the system with different sizes of different patient . At the ground there is a treadmill that train legs to walk in position of unloading , at the legs of patient we fix actuators that combined with a mechanism to stimulate the walking Operation . The system is automatic controlled by plc and other assistive devices .

### Biomedical Description :

#### 1.4.1 Electrical Muscle Stimulation (EMS)

We will use an electronic muscle stimulator (EMS) circuit that stimulates nerves of that part of your body where electrodes are attached. It is useful to muscle pain and revive frozen muscles that impair movement. EMS is applied by positioning electrodes on the skin. EMS devices offer a very convenient, effective and low cost method of exercising muscles. In most cases, EMS applications can be personally applied.

Electronic muscle stimulator is used to :

- 1- Increase sensory input to the brain .
- 2- Induce relaxation.
- 3- Arousal stimulation for awake from lethargy.
- 4- The performance of body movements with paralyzed muscles. Intelligent input of complex walking signals could enable a paraplegic to stand and walk.
- 5- To enable a quadriplegic to turn the page of a book For functional exercise to be effective, the reflex arc of a paralyzed muscle must be intact. I.e. The damage to the nerve cells must be in the brain or in spinal segment above the damaged nerve cells in order for EMS to be effective.[15]

### Physiological Basis of EMS

When we make the decision to contract a muscle voluntarily, our brain sends the order to the muscle in the form of a flow of nervous electrical impulses, called the action potential. This moves at high speed along the motor nerve by inverting the polarity of the cells across which it travels. At the end of the path, the information is communicated to the inside of the muscle cell by a neurotransmitter (acetylcholine) to trigger a complex process that finally

results in the shortening of the fiber. Contrary to common wisdom, the electricity used in the electrical stimulation process has no intrinsically beneficial effect on our muscles. The truth is that the process of electrostimulation stimulates the muscle via the motor nerve. This is most efficient and effective for two reasons. First, electrical stimulation of a motor neuron requires much less current than would be needed for direct stimulation of the muscle fiber and, second, the surface excitation effect achieved by using the nerve to distribute the current to all muscle fibers transmits the flow deep into the muscle. The physiology of muscle contraction and effort supplies us with very precise values of how the various muscle fiber types (slow, fast, intermediate, etc.) work and gives us a fairly detailed understanding of how different work rates correspond to the development of special types of muscle performance. The programs offered by the Complex Sport are particularly well suited to the physical quality the user wants to enhance. The pulse repeat frequency, the duration of each contraction, the rest time between contractions and the duration of each training program can all contribute to tailoring the training program to suit the precise objectives of the user

Electricity acts on the muscle by provoking muscle work and the muscle progress is nothing but the result of that work. The electrical pulses excite the motor nerve, which transmits to the muscle the order to respond mechanically. These pulses must be prepared to pass through the skin without getting deformed and arrive practically “clean” to specifically excite, without producing burning or electrical pain. Though each current pulse corresponds to an elementary work order, the muscle fibers responding to this order do a muscle response (a work unit).

The number of working fibers, meaning the amount of progressing fibers, depends on the power of the pulse. Powerful pulses are needed in order to work the maximum number of fibers and get the overcompensation phenomenon on the highest possible percentage of muscle fibers. To achieve this result, an efficient electro stimulation must produce very powerful contractions. Normally, when we talk about powerful electrical pulses, we think of electrical danger and pain. So an innovative solution was required to provide powerful pulses and at the same time, comfort, with no electrical pain (burning, electrical discharges, etc.). [16]

### **Function of The Stimulator**

- 1) Impose a considerable amount of work to the muscles, not limited by the mental and general physical fatigue.
- 2) Recruit an amount of muscle fibers bigger than the one obtained by voluntary contractions.
- 3) Improve the proprioceptive control.
- 4) Modify the fibers' typology.
- 5) Impose some beneficial work that the fibers cannot do with a voluntary contraction.
- 6) Improve the muscle elasticity.
- 7) Increase the strength.
- 8) Develop the explosive strength.
- 9) Have a much better and faster warm-up.

## 1.4.2 Electromyography (EMG) –Signals :

EMG is the profile of the electric signal detected by an electrode on a muscle.

### Physiological Basis of EMG

In the study of muscle physiology, neural control of excitable muscle fibers is explained on the basis of the action potential mechanism. The electrical model for the motor action potential reveals how EMG signals provide us with a quantitative, reliable, and objective means of accessing muscular information. When an alpha motoneuron as we see in the Fig.(1-6) cell is activated (induced by the central nervous system or as a result of a reflex action), the conduction of this excitation travels along the motor nerve's axon and neurotransmitters are released at the motor endplates. An endplate potential is formed at the muscle fibers and innervates the motor unit (the smallest functional unit where neural control over muscular contraction occurs).

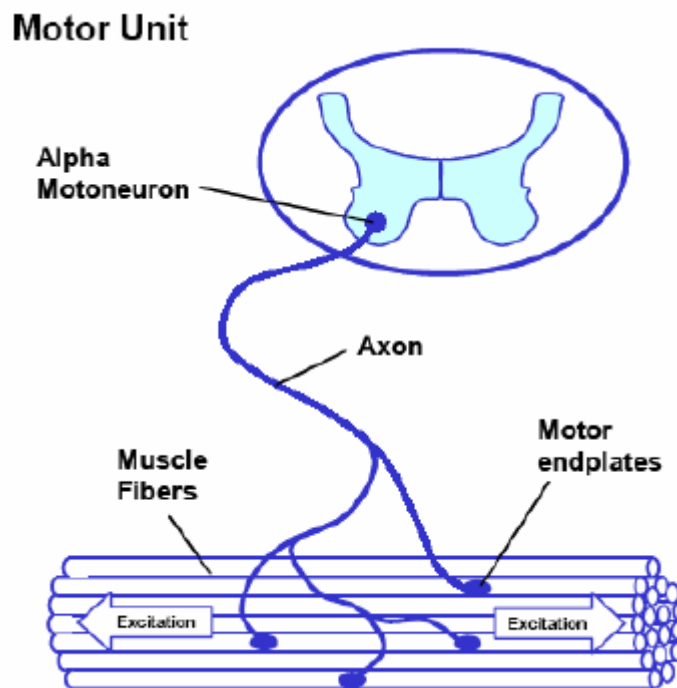

Fig.(1-6) Motor unit

Muscle fibers are composed of muscle cells that are in constant ionic equilibrium and also ionic flux. The semi-permeable membrane of each muscle cell forms a physical barrier between intracellular (typically negatively charged compared to external surface) and extracellular fluids, over which an ionic equilibrium is maintained. These ionic equilibriums form a resting potential at the muscle fiber membrane (sarcolemma), typically -80 to -90mV (when not contracted). This potential difference is maintained by physiological processes as we see in the Fig.(1-7) found within the cell membrane and are called ion pumps. Ion pumps passively and actively regulate the flow of ions within the cell membrane. When muscle fibers

become innervated, the diffusion characteristics on the muscle. Fiber membrane are briefly modified, and  $\text{Na}^+$  flows into muscle cell membranes resulting in depolarization. Active ion pumps in the muscle cells immediately restore the ionic equilibrium through the repolarization process which lasts typically 2-3ms.

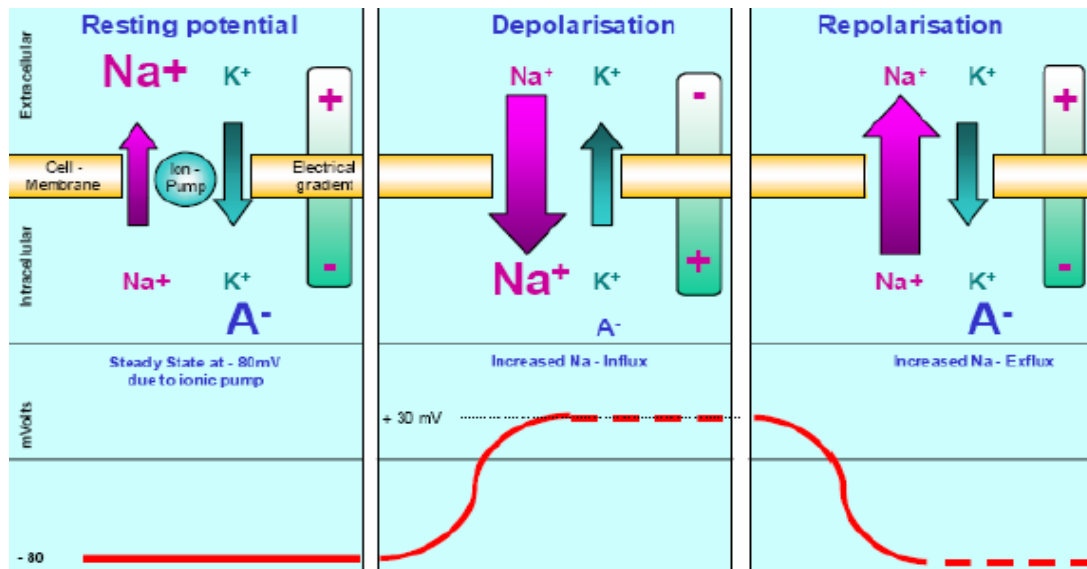

Fig.(1-7) physiological processes

EMG signals provide us with a viewing window into the electrical signals presented by multiple muscle fibers and are in fact a superposition of multiple action potentials. Electromyography (EMG) activity of four leg's muscles (rectus and biceps femoris, tibialis interiors and gastrocnemius) was recorded and analyzed. Electromyogram is the measurement of electrical current generated upon muscle contraction. When muscle fibers contract, there is an exchange of ions in the muscle fiber membranes, this flow of ions generates an electrical current. Flow of ions within muscle fiber membranes can be measured on the surface of the skin by using Argentum Chloride ( $\text{Ag}/\text{Ag}-\text{Cl}$ ) surface electrodes which convert ion flow into electron flow. [17]

From his normal gait. In order to assess the exact cause and find a solution to correct an individual's gait, an accurate and quantitative assessment of deviation is required. Dynamic electromyography (EMG) offers means of direct tracking muscle activity. The myo-electric signal sufficiently parallels the intensity of muscle action to serve a useful indicator of its mechanical effect. Amplitude of EMG signals derived during gait may also be interpreted as a measure of relative muscle tension. Data seem to support that, the linear envelope of the EMG signal reflects the relative amount of muscle tension. It has been concluded that the relationship is influenced by technique and physiological factors. Delineating the changes in phasing, duration, or magnitude of muscle action associated with a person's pathological gait pattern, however, is difficult due to the complexity of the EMG record. Its multi-spike, random amplitude quality defies simple interpretation. The timing and intensity of the EMG during a phase or the entire gait cycle inform about neurological control and muscle integration.

## **Application of EMG In Project :**

- 1- Muscle force EMG relationship : the relationship between muscle force and EMG activity is relatively linear.
- 2- Operation the stimulator circuit in the idle state .

## **Benefits of EMG In The Project**

Stroke victims and individuals diagnosed with incontinence (lack of voluntary control of excretory functions) typically undergo training regimens that enable them to regain functional control over specific muscles. The electrical activity normally present during a patient's muscle contraction and relaxation cycle is often characteristically different or much weaker and harder to detect on damaged muscle sites. Through careful and skilled placement of certain electrodes onto specific electrode sites, biofeedback provides the patient and therapist with objective information about the subject's muscle activity in real-time. The EMG user directly benefits from the instant feedback increasing his/her self-awareness of the muscular activity under direct conscious control, and accelerates the therapist's and stimulator to improve the patient's ability to complete specific movements. The patient initiates the muscle contraction and when a specific EMG threshold is not reached an electrical stimulation burst is delivered and the muscle and the patient is stimulated to complete the contraction. This technique provides the possibility of "getting the best of both worlds" in that it utilizes both passive and active rehabilitation techniques to aid and motivate the patient.

### **1.4.3 Human Heart rate :**

Heart rate is the number of heartbeats per unit of time, typically expressed as beats per minute (bpm). Heart rate can vary as the body's need to absorb oxygen and excrete carbon dioxide changes, such as during exercise or sleep.

The measurement of heart rate is used by medical professionals to assist in the diagnosis and tracking of medical conditions. It is also used by individuals, such as Patients with stroke, who are Walking in monitoring their heart rate to gain maximum efficiency from their training. Heart rate measurement is one of the very important parameters of the human cardiovascular system to indicate on a stress.

The resting heart rate ( $HR_{rest}$ ) is a person's heart rate when they are at rest, that is lying down but awake, and not having recently exerted themselves. The typical resting heart rate in adults is 60-90 bpm, with rates below 60 bpm referred to as bradycardia, and rates above 100 bpm referred to as tachycardia. Conditioned athletes often have resting heart rates below 60 bpm, with values of below 40 bpm not unheard of. For instance, cyclist Lance Armstrong has been known to have resting heart rates to as low as around 32 bpm, cyclist Miguel Indurain had a resting heart rate of 28 bpm. The low pulse in conditioned athletes is due to hypertrophy of

the cardiac muscles, therefore enabling a higher volume of blood being pumped at each beat .Your "safe heart rate" is a heart rate that is prescribed to help moderate and supervise your exercise training so that you don't over do it. This range is typically about 60% of the maximum heart rate and helps to reduce the amount of stress on the heart while gaining good effects of exercise. This is especially important if you have a heart condition or just starting an exercise regime. [18]

### 1.5 - Project Parts :

- 1- Mechanical overall structure
- 2- Electrical Control System

Both side consisting the following :

- Special Treadmill.
- Lokolift " Body weight support system (BWS).
- Lokomotor " Lower Limb moving assistance ".

### 1.6 Project Cost :

Table (1-1) project cost

No.	description	Amount "NIS"
1.	System Body	2500
2.	PLC	1500
3.	Touch Screen	1200
4.	Motors and controller	2500
5.	Sensors	3000
6.	Medical Equipments	1200
7.	Control Panel Element	1300
8.	Harness	600
9.	Other expenses	1000
Total Amount		16000 NIS

# CHAPTER "2"

## REHABILITATION AND DISEASE

---

2.1- Stroke

2.2- A Spinal Cord Injury

2.3- Rehabilitation

2.4- Physiology Physiotherapist

## 2.1 - Stroke:

### 2.1.a - Introduction

A stroke is a condition where a blood clot or ruptured artery or blood vessel interrupts blood flow to an area of the brain. A lack of oxygen and glucose (sugar) flowing to the brain leads to the death of brain cells and brain damage, often resulting in an impairment in speech, movement, and memory.[19]

The two main types of stroke include ischemic stroke and hemorrhagic stroke. Ischemic stroke accounts for about 75% of all strokes and occurs when a blood clot, or thrombus, forms that blocks blood flow to part of the brain. If a blood clot forms somewhere in the body and breaks off to become free-floating, it is called an embolus. This wandering clot may be carried through the bloodstream to the brain where it can cause ischemic stroke. A hemorrhagic stroke occurs when a blood vessel on the brain's surface ruptures and fills the space between the brain and skull with blood (subarachnoid hemorrhage) or when a defective artery in the brain bursts and fills the surrounding tissue with blood (cerebral hemorrhage). Both result in a lack of blood flow to the brain and a buildup of blood that puts too much pressure on the brain. show the Fig. ( 2-1 ) . [20]

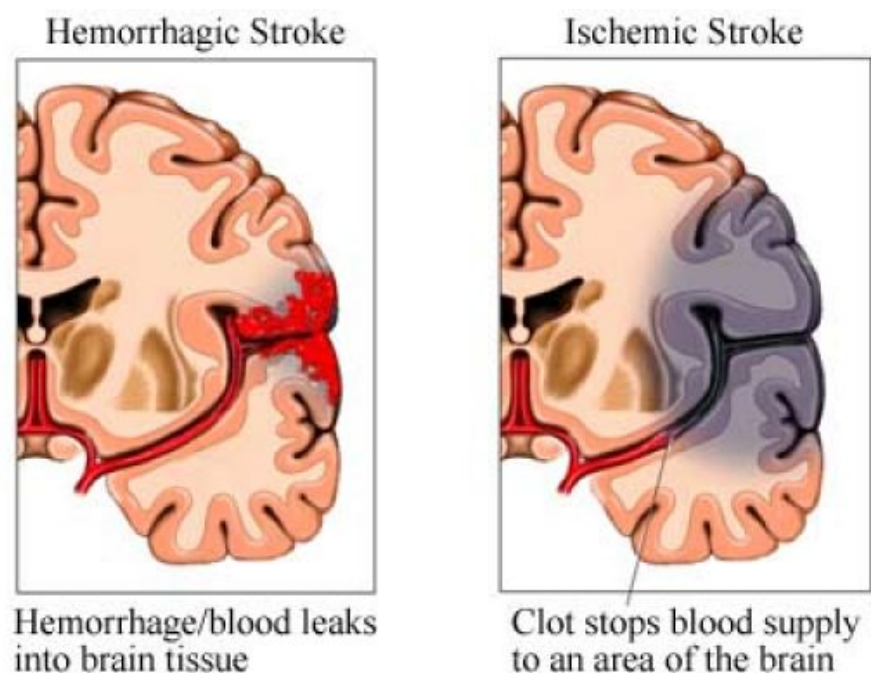

Fig. ( 2-1 ) The two main types of stroke

The outcome after a stroke depends on where the stroke occurs and how much of the brain is affected. Smaller strokes may result in minor problems, such as weakness in an arm or leg. Larger strokes may lead to paralysis or death. Many stroke patients are left with weakness on one side of the body, difficulty speaking, incontinence, and bladder problem.

### **2.1.b - Effects of a Stroke**

- 1) Weakness (hemiparesis) or paralysis (hemiplegia) on one side of the body that may affect the whole side or just the arm or leg. The weakness or paralysis is on the side of the body opposite the side of the brain affected by the stroke.
- 2) Spasticity, stiffness in muscles, painful muscle spasms
- 3) Problems with balance and/or coordination
- 4) Problems using language, including having difficulty understanding speech or writing (aphasia); and knowing the right words but having trouble saying them clearly
- 5) Being unaware of or ignoring sensations on one side of the body (bodily neglect or inattention)
- 6) Pain, numbness or odd sensations
- 7) Problems with memory, thinking, attention or learning
- 8) Trouble swallowing
- 9) Fatigue
- 10) Difficulties with daily tasks

### **2.2 - A Spinal Cord Injury**

A spinal cord injury damage to any part of the spinal cord or nerves at the end of the spinal canal often causes permanent changes in strength, sensation and other body functions below the site of the injury. If you've recently experienced a spinal cord injury, it might seem like every aspect of your life will be affected.

Many scientists are optimistic that advances in research will someday make the repair of spinal cord injuries possible. Research studies are ongoing around the world. In the meantime, treatments and rehabilitation allow many people with a spinal cord injury to lead productive, independent lives. [21]

### **2.3 - Rehabilitation For Lower Limb**

stroke affects everybody differently, and it is difficult to say how much of a recovery is possible. Many stroke survivors experience the most dramatic recovery during their stay under the physical therapy in the weeks after their stroke.

rehabilitation for lower limb help to restore physical functioning by evaluating and treating problems with movement, balance, and coordination and to provide exercises and practice to help patient perform activities of daily living.

## **2.4 - Physiology Physiotherapist**

Physicians have the primary responsibility for managing and coordinating the long-term care of stroke survivors, including recommending which rehabilitation programs will best address individual needs. Physicians also are responsible for caring for the stroke survivor's general health and providing guidance aimed at preventing a second stroke [22].

Physical therapists specialize in treating disabilities related to motor and sensory impairments. They are trained in all aspects of anatomy and physiology related to normal function, with an emphasis on movement. They assess the stroke survivor's strength, endurance, range of motion, gait abnormalities, and sensory deficits to design individualized rehabilitation programs aimed at regaining control over motor functions. Strategies used by physical therapists to encourage the use of impaired limbs include selective sensory stimulation. Both methods training on a body-weight supported treadmill or working on strength and balance exercises at home with a physical therapist resulted in equal improvements in the individual's ability to walk by the end of one year.[23]

# CHAPTER "3"

## ELECTRICAL AND MECHANICAL DESIGN

---

- 3.1- Introduction
- 3.2- Overall Structure
- 3.3- Treadmill
- 3.4- Body Weight Support "BWS" System
- 3.5- System Flow Chart
- 3.6- Biomedical Part Design
- 3.7- The Automation Part
- 3.8- Software
- 3.9- Safety and Protection

### 3.1- Introduction :

Lower Limb Rehabilitation System consist from mechanical and electrical components. The Mechanical side design from square metal " Profile " and some pulley and gear, all this component to support the electrical component and provide the safety to patent.

Electrical side is the main side in Lower Limb System, this section consist from two part :  
1-Motion and Movement Part , 2- Control Part .

Motion and Movement Part consist from Treadmill Motor two move the belt of treadmill to help the patent in training, Winch motor to move and support the patent body.

Control part consist from PLC and Touch screen and some control and protection element and motor controller and sensors.

### 3.2 - Over all structure (shown in Fig.(3-1)) Description :

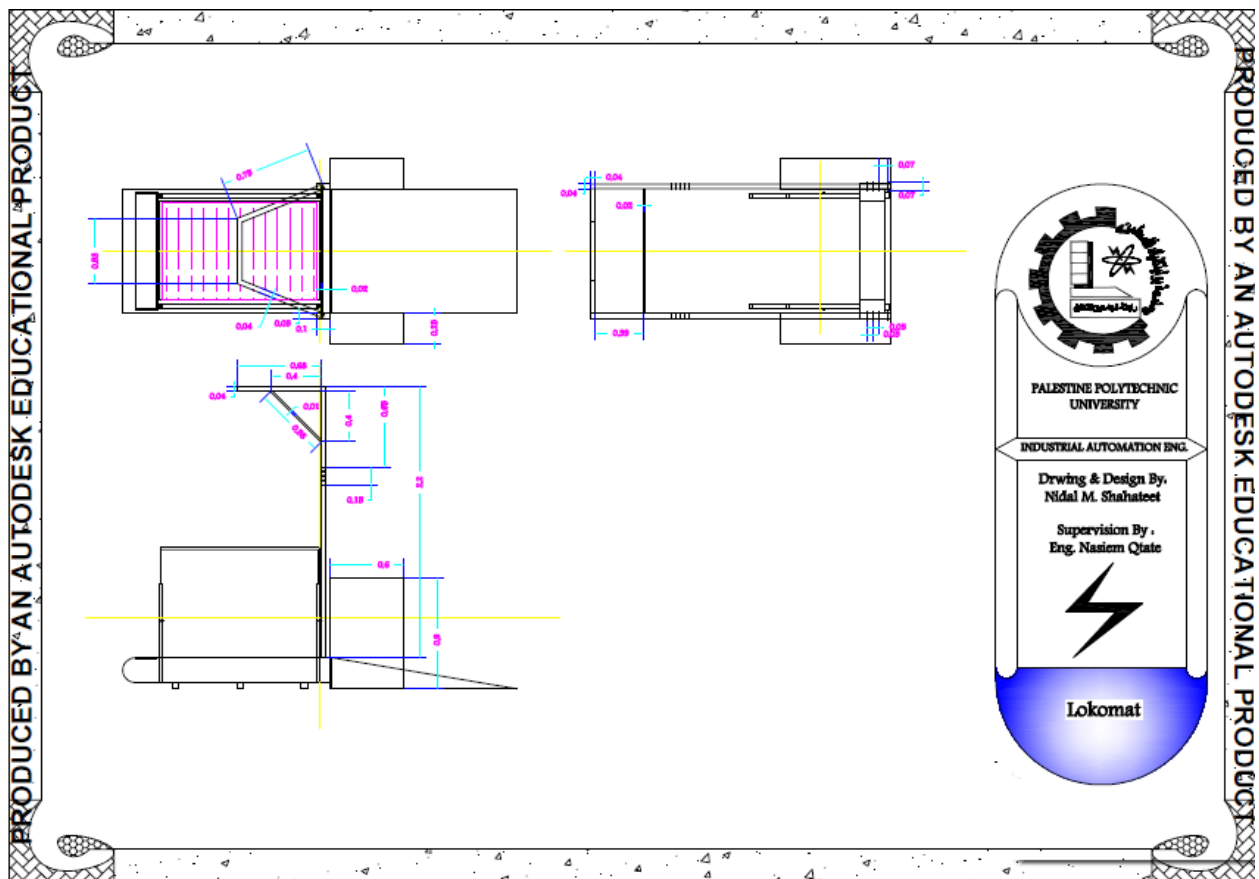

Fig.( 3-1 ) Over all structure

Overall structure width designed based on standard wheelchair dimensions because the patient come to treadmill on wheelchair, the oblique section is designed to facilitate the process of the rise of the patient on the wheelchair to the treadmill .System Length was divided into two section, oblique section of the part can be separated from the parts of the system by linking and the high designed To fit the length of the human body is designed to cut easily separated. Connections designed upon overlapping pieces of profile iron with deferent dimensions , pieces enter to each other and fixed by using tighten screws .

Iron profile which used to built the project have a dimensions ( 50x50mm) in Fig.(3-1)and ( 20x20mm) in Fig.(3-2), with thickness (2mm ) , and screws using to fix the connections have a diameter ( 13mm ) .

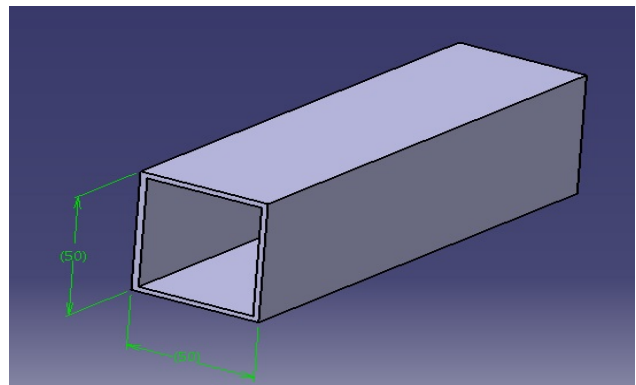
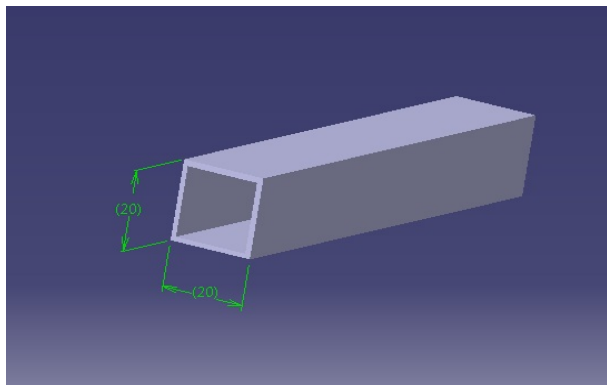

Fig.(3-2).Profile rods with dimensions (20x20 mm)

Fig.(3-3).Profile rods with dimensions (50x50 mm)

building structure of treadmill based upon specific design in order to give strength and durability to hold the max expected weight that put over treadmill without any danger on patient and structure .two sides metal pipes with diameters (3/4 )" and (1/2 )" form a side handle , shown in Fig.(3-4)



Fig.(3-4) Side Handle

This handle used to help patient standing up and maintain the equilibrium of patient body while training on this system , we can lift and install this handle by a very simple movement based upon overlapping pipes and use control screws to adapt the high of handle. cut these Pieces upon measurements we do and compound with each other by welding and tensile bolts as designed. Then we have the overall structure with dimensions based on our design , shown in Fig.(3-5) :

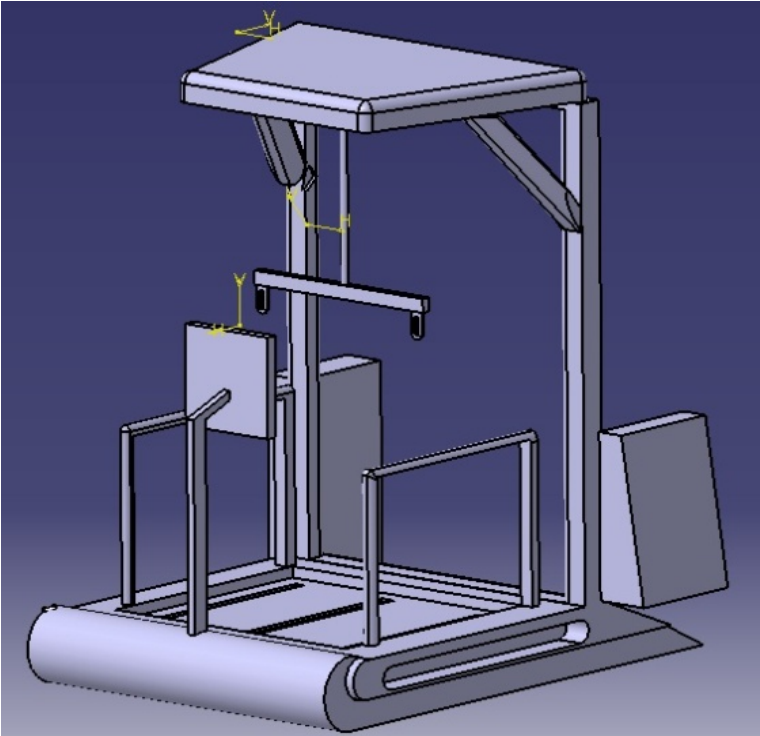

Fig.(3-5) overall structure

The over all structure which we build shown in Fig.(3-6)



Fig.(3-6) The over all structure

### 3.3 – Treadmill

A treadmill is an exercise machine for running or walking while staying in one place. The machine provides a moving platform with a wide conveyor belt and an electric motor or a flywheel. The belt moves to the rear allowing a person to walk or run an equal, and necessarily opposite velocity. The rate at which the belt moves is the rate of walking or running. Thus, the speed of walking may be controlled and measured.

## Treadmill Design :

Treadmill is an electromechanical device consist of a permanent magnet dc motor connected through a timing gear with a rear roller that move a walking belt upon treadmill deck and controlled by a suitable controller, it's contain a weight sensor under walking belt to measure the weight of person .The dimensions of treadmill chosen to allow the wheel chair stand on it before lockolift hold the patient, also one of side surfaces designed as a slant to enable wheel chair climb on the treadmill , the gap closed by a door over motor position designed to facilitate the maintenance of some treadmill parts.

Is Built treadmill structure as shown bellow in Fig.(3-7) with dimensions (160\*100cm) by welding Pieces of iron with different lengths then we have Truss shown below that will cover by iron sheets:

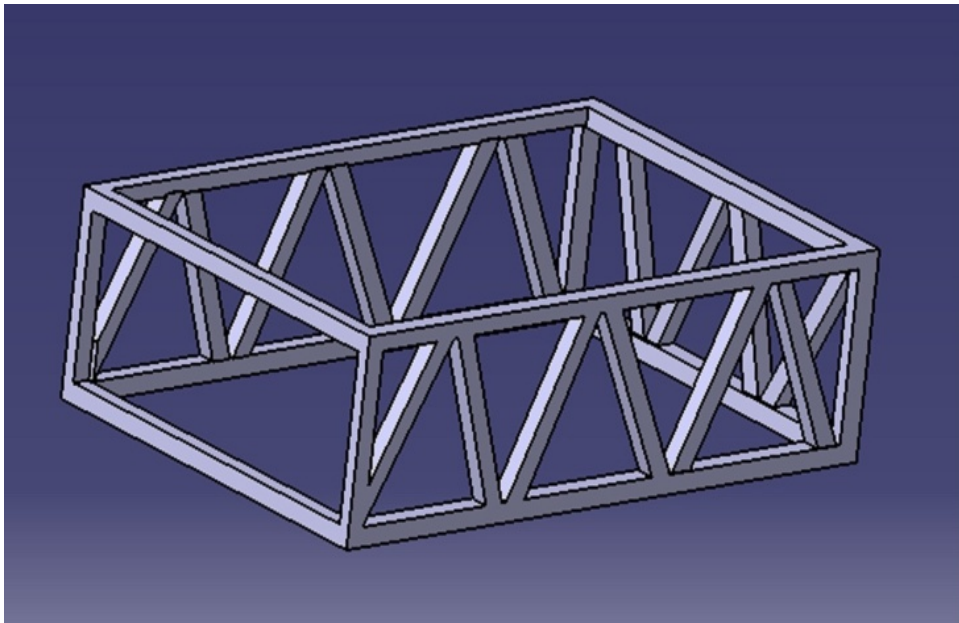

Fig.(3-7) treadmill structure

Treadmill which is built shown in Fig.(3-8)



Fig.(3-8) Treadmill

### **Treadmill Parts**

- 1) Permanent magnet DC motor " PM "
- 2) Timing gear
- 3) Weight sensor
- 4) Controller
- 5) Rear roller
- 6) Walking belt
- 7) Treadmill deck

**1) Permanent Magnetic (PM-DC) motor :**

permanent magnet dc motor used in project to move treadmill belt .Speed controlling of this motor based upon voltage changing to have the required speed , for that a chopper circuit is use and it's explained in control section .permanent magnet dc motor shown in Fig.( 3-9)



Fig.(3-9) PM-DC motor

Table(3-1) : PM-DC motor name plate

P.M.D.C . motor model :	C3364B3487
P/NM –	243340
2.8 HP @	130 VDC / 2089W
1.75HP cont. Duty @	100VDC / 1305W
E6	2788
INS .	Class H
OPEN	CONST
EXTERNAL	FAN
MATERIAL	UL RECOGNIZED

This PM-DC Motor operate at 100V DC in continuous mode operation and generate 1.75 HP output mechanical power and the nominal speed of this motor 2000 rpm and the

isolation coiled paper class H , and should be run the external motor fan to cooling the motor coils .

## 2) Timing Belts gear :

Synchronous / Timing belts are basically endless flat belts which pass over pulleys- the belts having grooves which mate with teeth on the pulleys, show Fig.(3-10). These belt drives, unlike flat and vee belt drives are positive. Any slip of the belt relative to the pulleys is minor in degree and is due to belt stretch, or erosion of the grooves. These belts are used for power transfer and for synchronized drives to ensure that the driven pulley is always rotating at a fixed speed ratio to the driving pulley .

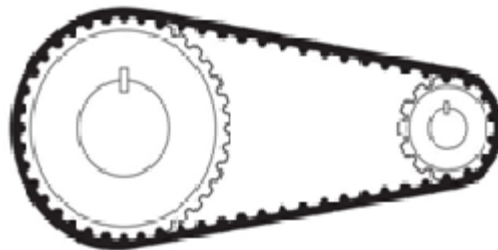

Fig.(3-10) timing gear

Treadmill system should be use the timing gear to translate the motor rotation to the treadmill belt through the roller, and to constant speed control and high response [24] .

## 3) Treadmill deck :

The treadmill deck, which is the treadmill's floor frame that holds the belt in place, should be completely smooth and free from exposure to wood, pits or grooves. It must with a string to hold the person and the wheel chair.

## 4) Walking belt

Walking belt is the moving part of treadmill where the person walking on , it's made basically from strong rubber, show Fig.(3-11) . The running belt for motorized treadmill is with structure of double cloth bases and double PVC rubber ,that makes the running belt with lower ductility and excellent physical character , belt positioned over a deck and moved by rear roller that connected with a motor through timing belt , with a time ; belt will lose their strength and tenacity and it must replaced with a new , belt movement must synchronized with a roller and it's not allowed any slip between them .

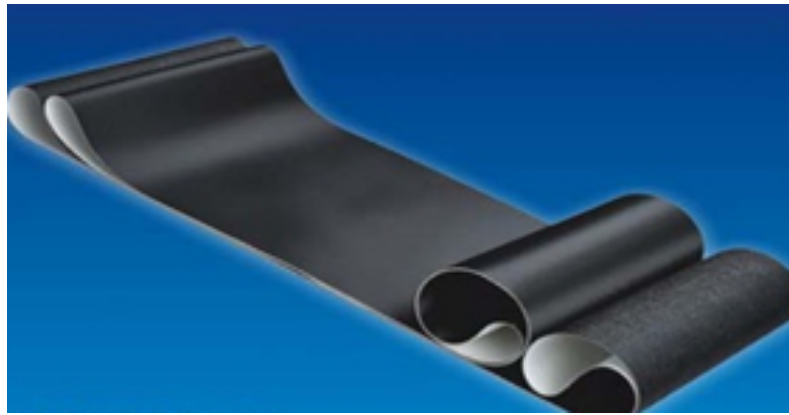

Fig.(3-11) walking belt

### 5) Rear roller :

Roller is a cylindrical rode made from steel , it's fixed between the two edges of treadmill and connected with motor throw timing belt gear, treadmill belt warped around rear roller and it must in standard tension , so when the motor rotate it move the roller and the roller move the belt, Fig.(3-12) .

Roller diameter is one of the most overlooked features of a treadmill , Basically, the larger the diameter of the rollers and the fewer revolutions will be required to make at any given belt speed. This significantly reduces wear and tear on the roller and its bearings not to mention the belt. Larger rollers allow a manufacturer to use larger bearings, allowing them to handle more belt stress and suffer less shaft deflection. A larger roller also means longer tread-belt life, since there is less stretching of the belt [25] .



Fig.(3-12) rear roller

### **3.4 Body Weight Support "BWS" System**

#### **3.4.1- BWS Description :**

Lokolift or Body weight support (BWS) system are increasingly being used in conjunction with treadmills to assist therapists in gait training of patients with neurological impairments.

Paralysis of the leg muscles often prevents patients from supporting their own body weight during stance phase. Reducing the gravitational forces acting on the legs by a BWS system would reduce the load that needs to be overcome by the patient and facilitate stepping movements. In addition, the BWS system ensures safety and stability of the patient walking on the treadmill [26] .

Body weight support systems applied to gait therapy normally consist of a harness system worn by the patient, ropes and pulleys, and a counterpoise to unload the patient.

### 3.4.2 - BWS Design

the active BWS system designed to achieve the natural gait of human, show in the Fig.(3-13).

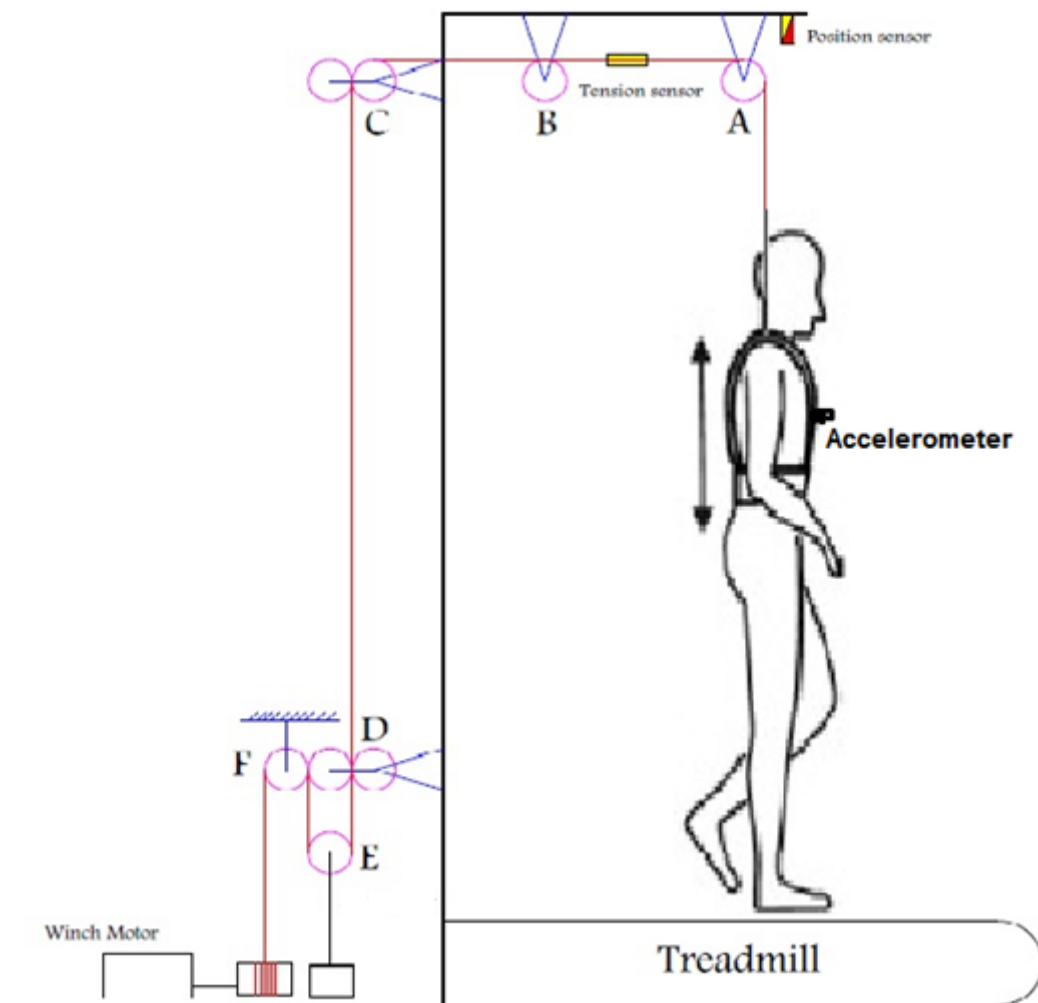

Fig.(3-13) active BWS system

The Active BWS System in Fig.(3-13) , consist of the following component :

- 1) Rope Pulley System
- 2) Winch
- 3) Harness
- 4) Position sensor
- 5) Tension sensor
- 6) Accelerometer
- 7) Treadmill load cell

## Component Description :

### 1) Rope Pulley System :

A pulley, also called a sheave or a drum, is a mechanism composed of a wheel on an axle or shaft that may have a groove between two flanges around its circumference. A rope, cable, belt, or chain usually runs over the wheel and inside the groove, if present. Pulleys are used to change the direction of an applied force, transmit rotational motion, or realize a mechanical advantage in either a linear or rotational system of motion, show Fig.(3-14). It is one of the six simple machines. Two or more pulleys together are called a block and tackle.



Fig.(3-14) Pulley System

Rope that carry the harness chosen with string to carry patient without any dangerous, The pulley system consist of the rope and six pulleys installed in special design to achieve the required torque and force that can hold patient safely , the design shown in Fig.(3-15)

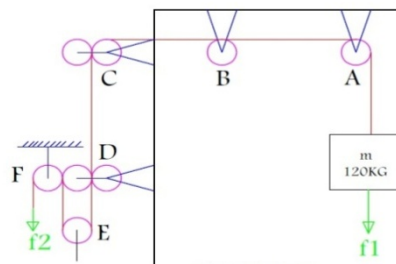

Fig.(3-15) BWS System

In the Active BWS System can will be used five fixed pulley and one movable pulley. Pulley A and B support the rope in horizontal direction , pulley C and D designed to support and flexible catch the rope in the vertical direction , pulley E connect on the stepper motor through Lead Screw to adjust the trainer gait , pulley F support the rope and increasing the winch force [27]

## 2) Winch :

A winch is a mechanical device that is used to pull in (wind up) or let out (wind out) or otherwise adjust the "tension" of a rope or wire rope (also called "cable" or "wire cable"). In its simplest form it consists of a spool and attached hand crank. In larger forms, winches stand at the heart of machines as diverse as tow trucks, steam shovels and elevators. The spool can also be called the winch drum. More elaborate designs have gear assemblies and can be powered by electric, hydraulic, pneumatic or internal combustion drives. Some may include a solenoid brake and/or a mechanical brake or ratchet and pawl device that prevents it from unwinding unless the pawl is retracted. In the Active BWS System can be used the electrical motor to moving the winch drum and pull or push the rope and emergency manual winch to pull or push the rope in the emergency state [28] .

Winch component :

- a) Square Cage Induction motor
- b) Electrical break (solenoid break)
- c) Drum

### a) Square Cage Induction motor

The winch motor selecting of AC Induction Motor type because the advantages above of this type and Suitability in the winch application.

for winch we use a 3- phase squirrel cage induction motor with specifications , n (max speed) = 1500 rpm , number of poles = 4-pole , frequency = 50 Hz , output power = 0.5 HP ,  $\Delta / Y = 220 / 380v$  .

With this motor we use gear box it's conversion range from 1 : 100 , and 220v / 50 Hz solenoid break .Motor shown in Fig.(3-16)

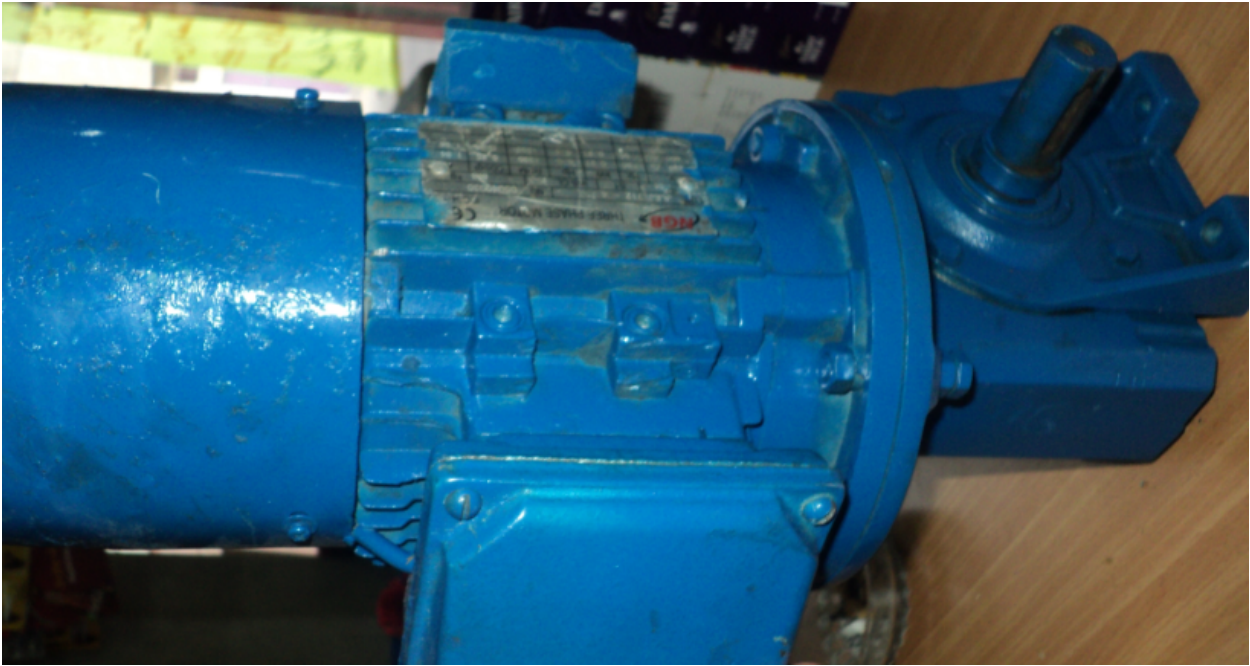
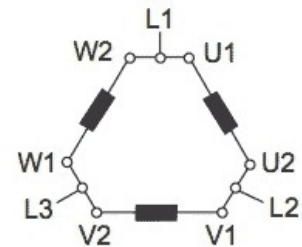
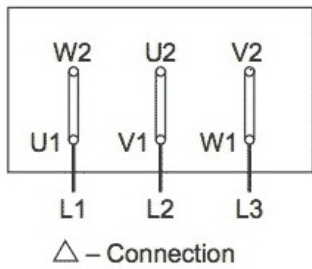

Fig.(3-16) Induction motor

To use this motor we must convert it to 1- Ph , Converting 3-ph IM to 1-ph done by connect the phase line to first phase connection point (a) , and neutral to second (b) , and connect a capacitor between second and third connection point ( around one of three coils ) , all that shown in Fig.(3-17)

3-  $\Phi$  induction motor



Convert to 1-  $\Phi$  induction motor

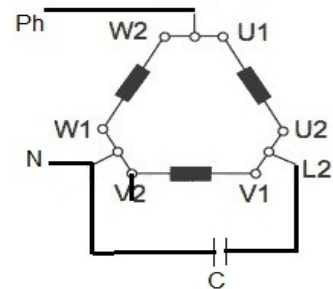
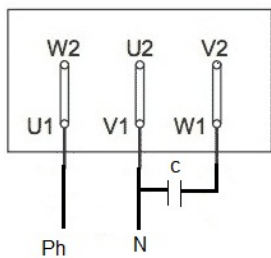

Fig.(3-17) converting 3phase induction motor to 1 phase

But there is a number of terms must achieve in ( 3-ph IM ) to allow converting to ( 1-ph IM ) and that listed below :

- 1) the motor allowed to connect Y in 3- ph
- 2) enabled to connect Δ in 1-ph
- 3) connecting neutral line with motor
- 4) it's power must less than 3 kw.
- 5) for every kw we use capacitor of 70 μF .

Motor we use have the specifications : 230 v Δ , 50 Hz , P ( kw ) = 0.37 , P ( HP ) = 0.5 , n = 1330 rpm , I = 1.84 A .

induction motor used as a winch in body weight support part , it's name plate shown in Table(3-2)

Table(3-2) : induction motor name plate

Three phase motor						
TYPE :		JLEJ		712	–	4
NO : 05050030						
IP : 55		S1			INS.CL	F
V	Hz	KW	HP	RPM	COS Φ	A
230 Δ	50	0.37	0.5	1330	0.75	1.84
400 Y	50	0.37	0.5	1330	0.75	1.06

this motor used in project as winch to hold patient from wheel chair and stand him on treadmill , so after patient wear a harness , push on lift button on COB then motor hold the patient and tension sensor measure patient's weight that take as set value , after that push on down button on COB to stand patient on treadmill and make him ready to start training on device

For this motor ( winch ) a gear box with ratio ( 1: 80 ) is used to increase the motor torque and make it able to hold Person easily , also it used to decrease motor speed from 1330 rpm to 12.6 rpm and make induction motor suitable for this application( winch ). With this motor , a 220 VDC / 50Hz solenoid break is used to stop the rotation of motor immediately when release the button on COB ( lift , down ) also in emergency conditions . when electricity reach this break , it work and stop the rotation of motor , when electricity cut from break it will off .

### b) Electrical break (solenoid break)

A Solenoid Brake is an electrically controlled brake. The brake is turned on and off by an electrical solenoid. Typically a spring engages the brake when unpowered, and the solenoid releases it when powered Fig.(3-18). These are used along with a mechanical brake to manage the load on a cargo winch. They're also used in electric wheel chairs, hoists, printers, photocopiers, etc. The winch break in the Active BWS System installed to increase safety of trainer and can be used as an additional break through to electrical motor internally break.[29]



Fig.(3-18) electrical break

### c) Winch Drum :

The single-drum research winch has been the data-gathering mainstay of seagoing wire (rope) handling and storage since the activity passed the hand-line and bucket stage. A primary advantage of a “Load Drum” winch is the directness of the cable’s path, when compared to a traction machine. At the winch, the cable bends itself continuously in the same direction with small radius changes as the drum fills or empties. Overboard sheaving is common to both types of winch. The Active BWS system winch using drum with emergency manual hand and converter mechanical switch. The Drum dimension selecting to suit the rope length and the BWS cabinet space, show in the Fig.(3-19), Table (3-3) contained the drum dimension[30].

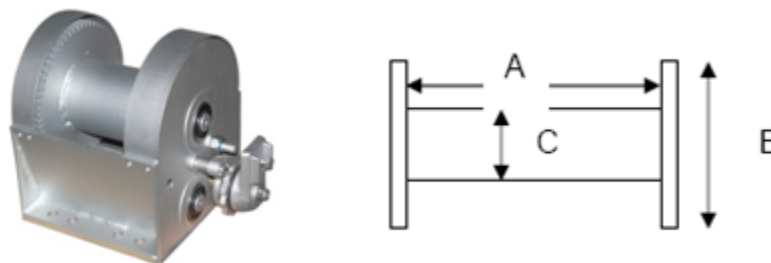

Fig.(3-19) Winch Drum

Table (3-3) drum dimensions

<b>Traverse (A)</b>	<b>10 cm</b>
<b>Flange Diameter (B)</b>	<b>16 cm</b>
<b>Barrel Diameter (C)</b>	<b>10 m</b>

### 3) Harness

A human harness is used for bondage. It is made with leather, and is wrapped around your body in such a way that it cannot be slipped off. The person who is wearing it will have his/her hands strapped behind his/her back. D-rings can be attached, so ropes or chains can be put on to lead the person around. In BWS the harness use to catch the trainee and also works to correct the status of the body and it tied in winch rope to lift and balance the human body through the training.

We design a harness from flax belts and for different size of persons to increase the range of users , the design take care of medical side , so the weight of patient spread equally on harness and there is no concentration of stress on body parts .

### 4) Position sensor :

The aim from using this sensor is to prevent impact patient head with the top of project structure , so it's used as protection tool .This sensor give a voltage when the patient head reach a specific distance from sensor , this voltage entered to PLC , then PLC give command to stop the winch .This sensor is fixed vertically on top of the structure and over patient position .Fig.(3-20) shown position sensor

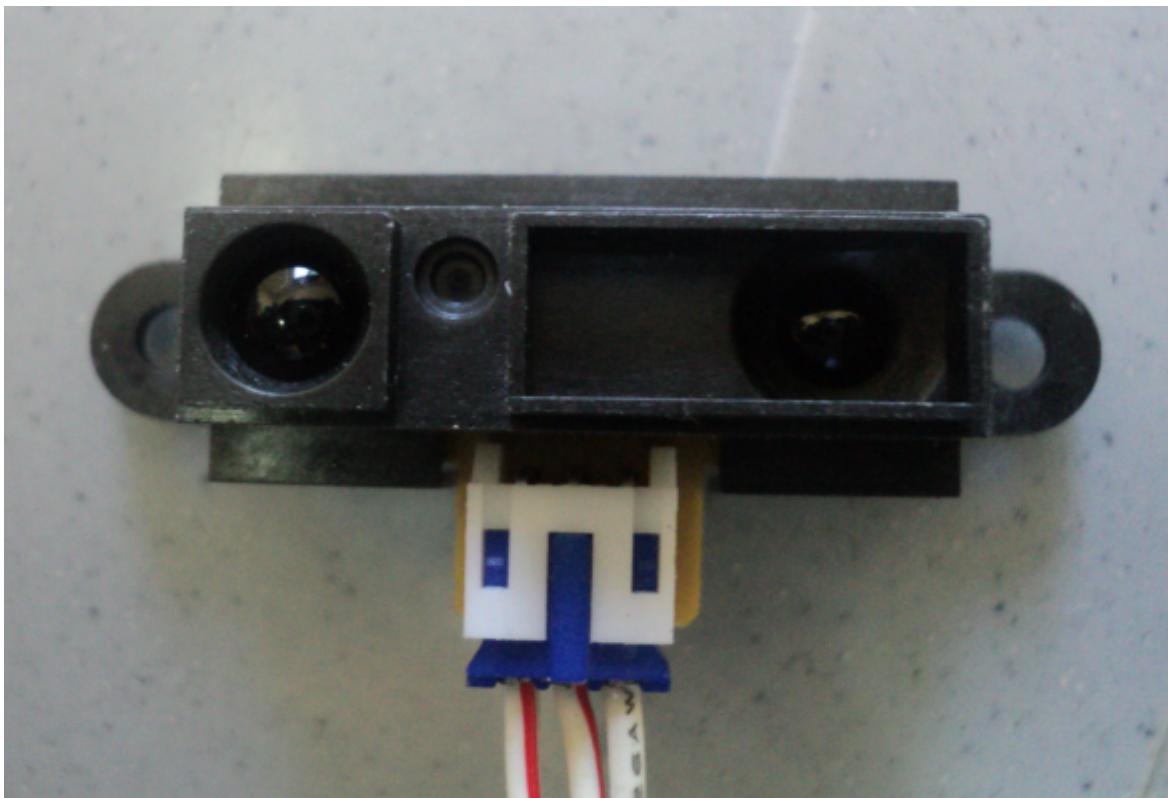
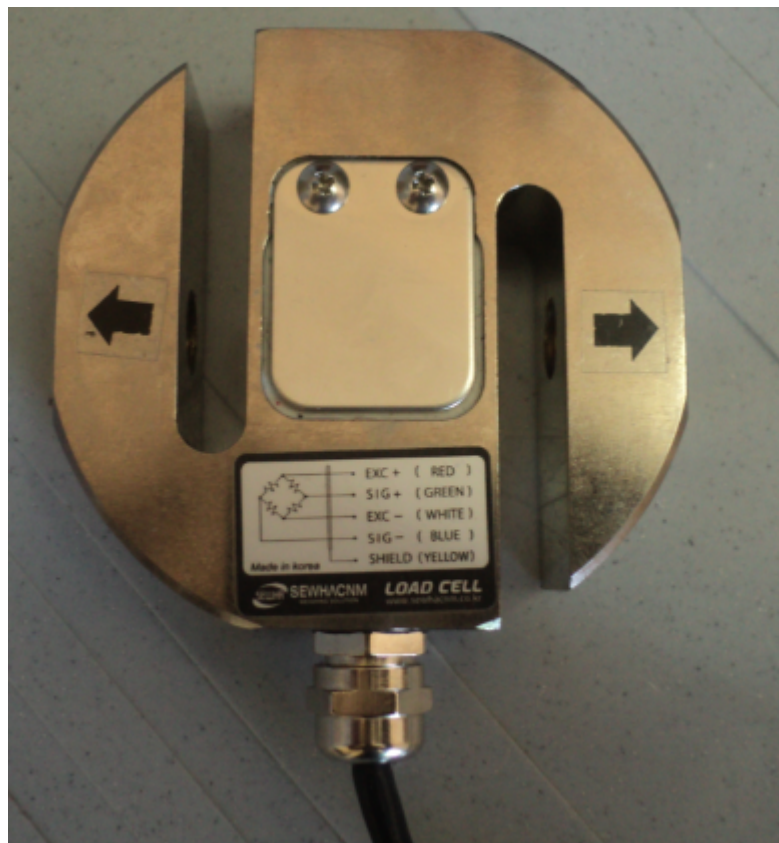

Fig.(3-20) Position sensor

### 5) Tension Sensor :

using tension sensor in this project is to measure the weight of patient , and take this weight as a set value that save inside PLC.Tension ( weight ) measured by tension sensor is translated at the output of this sensor as voltage enter to PLC via analog input connection , PLC translate this voltage upon internal program and displayed it on touch screen as the person weight.This sensor fixed though the rope that carry a patient .Model use shown in Fig.(3-21)



Fig(3-21) Tension Sensor

## 6) Accelerometer :

This sensor is one of protection tools in this project. When patient fall forward ( Z axis ), this sensor give a signal to PLC , then PLC give a command to winch to catch person and hold him then stop treadmill . Fig.(3-22) shown Accelerometer



Fig.(3-22) Accelerometer

## 7) Load cell :

Fig.(3-23) show the load cell



Fig.(3-23) load cell

In project this sensor used to stop downloading the patient on treadmill automatically when the weight exist on treadmill reach the set value calibrated on touch screen .A percentage of total patient weight is set in PLC , when the loaded weight over treadmill reach the set value of weight , the load cell give measured value to PLC that compare it with a percentage set and PLC give a command to winch to stop downloading on treadmill .This sensor fixed under treadmill deck .

### 8) Magnetic encoder :

A magnetic encoder consists of a rotating gear made of ferrous metal and a magnetic pick-up that contains a permanent magnet and the sensing element .. when metal disk that fixed on rotor the encoder give a count , every count mean one rotation , and from number of rotation in time the speed of motor can be calculated .Fig.(3-24) show the Magnetic encoder



Fig.(3-24) Magnetic encoder

### 3.4.3 - Design calculation :

#### Winch motor :

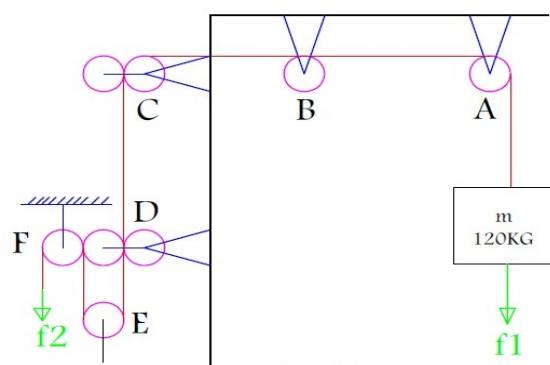

Fig.(3-25) BWS load

In the Fig.(3-25) show the winch analysis .

Now, the total force

$$f_1 = m \cdot g \quad \text{Equation ( 3-1 )}$$

Assume the max. body weight "m =120 Kg "

$$f_1 = 120 \times 9.8 = 1176 \text{ N}$$

$f_1 = f_2$  but in actual  $f_1 > f_2$  , because effect the pulley system to increase the winch force [].

Therefore, the winch required force  $f_2$  to move  $f_1 = 1176 \text{ N}$

To calculate  $f_2$  can be applied the following formula :

$$f_2 = \frac{c^{n(c-1)}}{c^{n-1}} f_1 \quad \text{Equation ( 3-2 )}$$

C - the pulley constant from standard table

n - number of the rope pass through the pulley

Fig.(3-26) describe the analysis of pulley system .

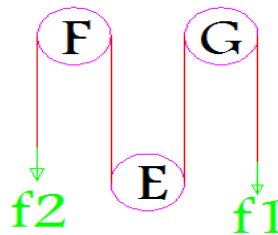

Fig.(3-26) pulley system

From Fig.(3-38), the pulley the rope pass through F and E pulley directly but another pulley (A,B,C,D) don't effect directly in the force because the rope don't pass through pulley .

Therefore, can be reduce pulley (A,B,C,D) in one pulley "G", now (n=3) and select the value of constant ( C = 1.08 ) , by apply the equation (2):

$$f_2 = \frac{1.08^3 \times (1.08 - 1)}{1.08^3 - 1} \times 1176 = 458 \text{ N}$$

Now, the torque of load at left side

$$T_L = \frac{1}{2} D \cdot f_2 \quad \text{Equation ( 3-3 )}$$

Winch drum diameter D=10cm, therefore the torque

$$T_L = \frac{1}{2} \times (10 \times 10^{-2}) \times 458 = 23 \text{ N.m}$$

Calculation For IM :

specification of motor we use (3 phase induction motor) is :

$$n_{nominal} = 1330 \text{ rpm}, P_{out(mech.)} = 0.5 \text{ HP}$$

Accordinging of this specification we calculate output torque and speed :

$$T_{out(motor)} = \frac{P_{out(mech.)}}{\omega}, \quad \text{Equation ( 3-4)}$$

$$\text{but } \omega = \frac{2\pi n}{60} = 140 \text{ rad / s}$$

$$P_{out} = 0.5 \text{ HP} = \frac{746}{2} = 373 \text{ w}$$

$$T_{out(motor)} = \frac{373}{140} = 2.66 \text{ N.m}$$

Gear ratio :- 1 : 80

$$T_{after \text{ gear}} = 2.66 * 80 = 212.8 \text{ N.m}, \quad \omega_{after \text{ gear}} = \frac{1330}{80} = 16.62 \text{ rad / s}$$

Motor which we used (3~ AC induction motor 400/230 V  $\sqrt{3}/\Delta$ , 50Hz,  $P_{out} = 373 \text{ W}$ , 1330 rpm ) But this motor produce torque ( $T = 2.66 \text{ N.m}$ ) and the required load torque (23 N.m);Therefore should be use gear in ratio "1:80" to reduce the speed of the motor .

### 3.5 - System Flow Chart

Fig. (3-27) show the System Flow Chart

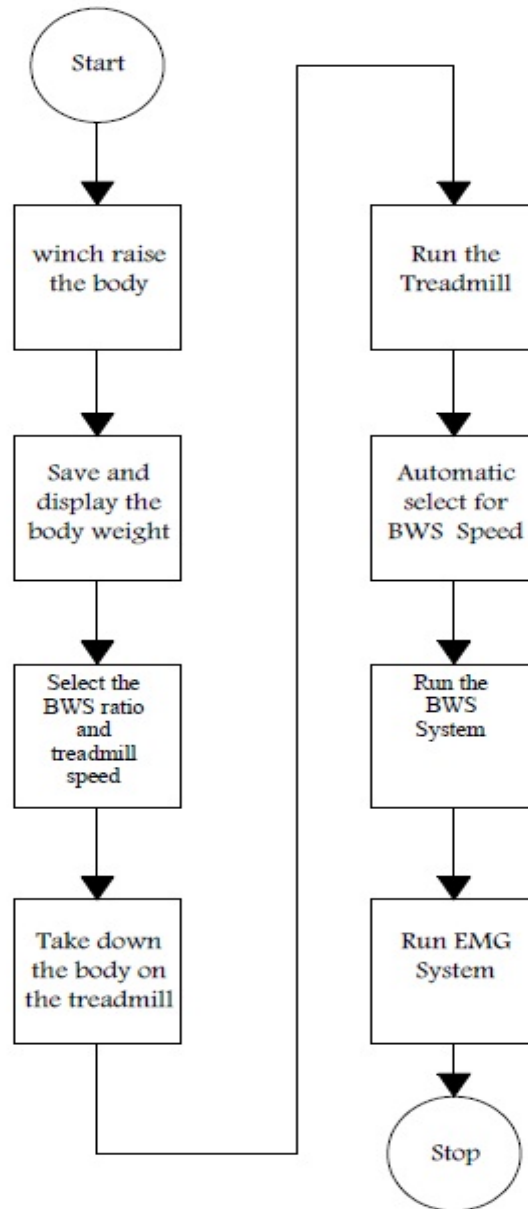

Fig.(3-27) system flow chart

### 3.6 - Biomedical Part Design

#### 3.6.1.a Block Diagram of Electromyography(EMG)

shows the block diagram in Fig.(3-28) of the proposed device

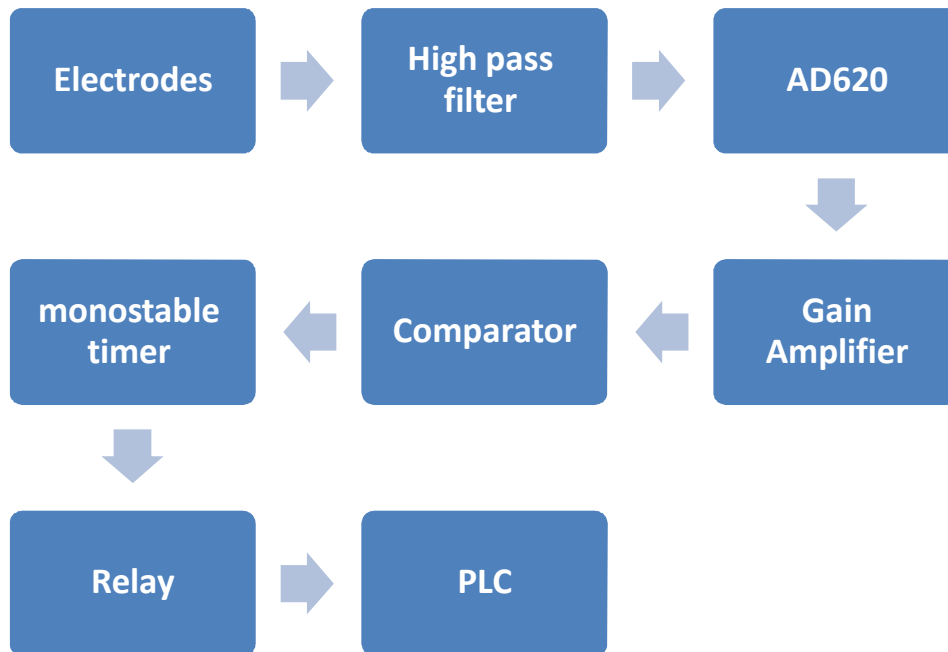

Fig.(3-28) Block diagram of EMG

#### Description Block Diagram

##### 1) Electrodes

It is conductor that convert the ionic current to the electric current. There are many types of the electrode , The most commonly used is (Ag/Ag-Cl) electrode.

#### General Electrodes Placements Sites & Reference Electrode

Differential electrodes are connected to any muscle on the leg as we see in the Fig.( 3-29) placement of the reference electrode is typically more proximal and away from the differential electrodes, preferably on electrically neutral tissue .Beginning from the motor end plates, the action potential spreads across the muscle fibers in both directions at a propagation speed of 2-6m/s. The action potential leads to a release of calcium ions in the intracellular fluid and produces a chemical response resulting in a shortening of the contractile elements of the muscle cells. [31]

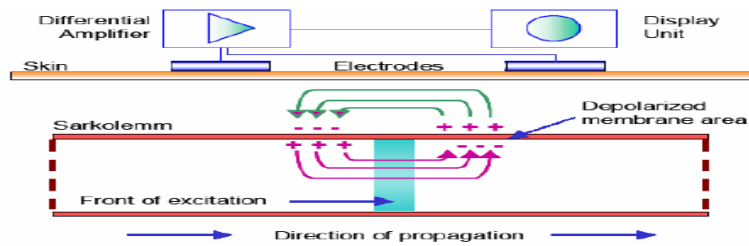

Fig.(3-29) Electrodes Placements Sites

Electrodes in contact with this wave front present a bipolar signal to the EMG differential amplifiers because the electrodes are measuring the difference between two points along the direction of propagation of the wave front. EMG signals provide us with a viewing window into the electrical signals presented by multiple muscle fibers and are in fact a superposition of multiple action potentials.

## 2) AD620 Amplifier

We used the AD620 which has high common mode rejection ratio High common mode rejection ratio means high capability of the AD620 to subtract noise which appears as common mode signals to the instrumentation amplifier inputs The AD620 is high accuracy instrumentation amplifier that requires only one external resistor to set gains of 1 to 10,000.

## 3) High Pass Filter

(HPF) is a device that passes high frequencies reduces the amplitude of frequencies lower than its cutoff frequency , It is sometimes called a low-cut filter or bass-cut filter ( in the previous circuit the minimum frequency 20 HZ ) .

## 4) Gain Amplifier

Used in the circuit to amplification the signal resulting from the HPF with gain = 310 .

## 5) Monostable 555 timer

Used in the circuit because it is useful for creating a timing period of fixed duration in response to stimulator circuit.

## 6) Transistor (NPN)

Used as a switch to operate A relay

### 3.6.1.b Circuit Design

shows the circuit of EMG in Fig. ( 3-30 ) [32] . And control circuit in Fig.(3-31) [33].

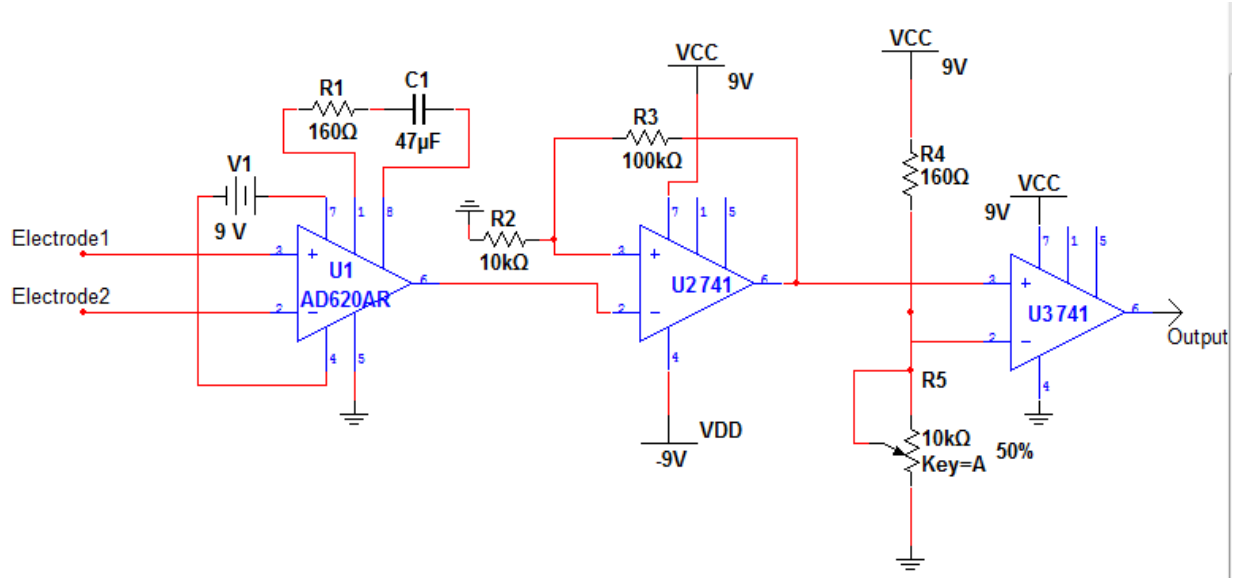

Fig. (3-30) EMG circuit

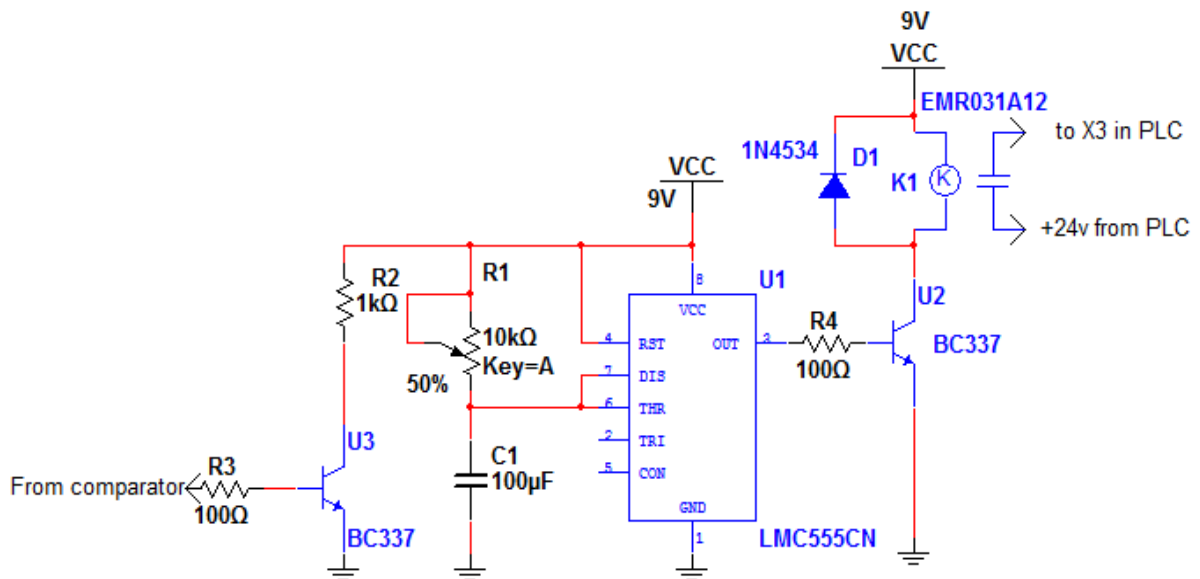

Fig.(3-31) control circuit

Fig.(3-32) show the circuit which we built

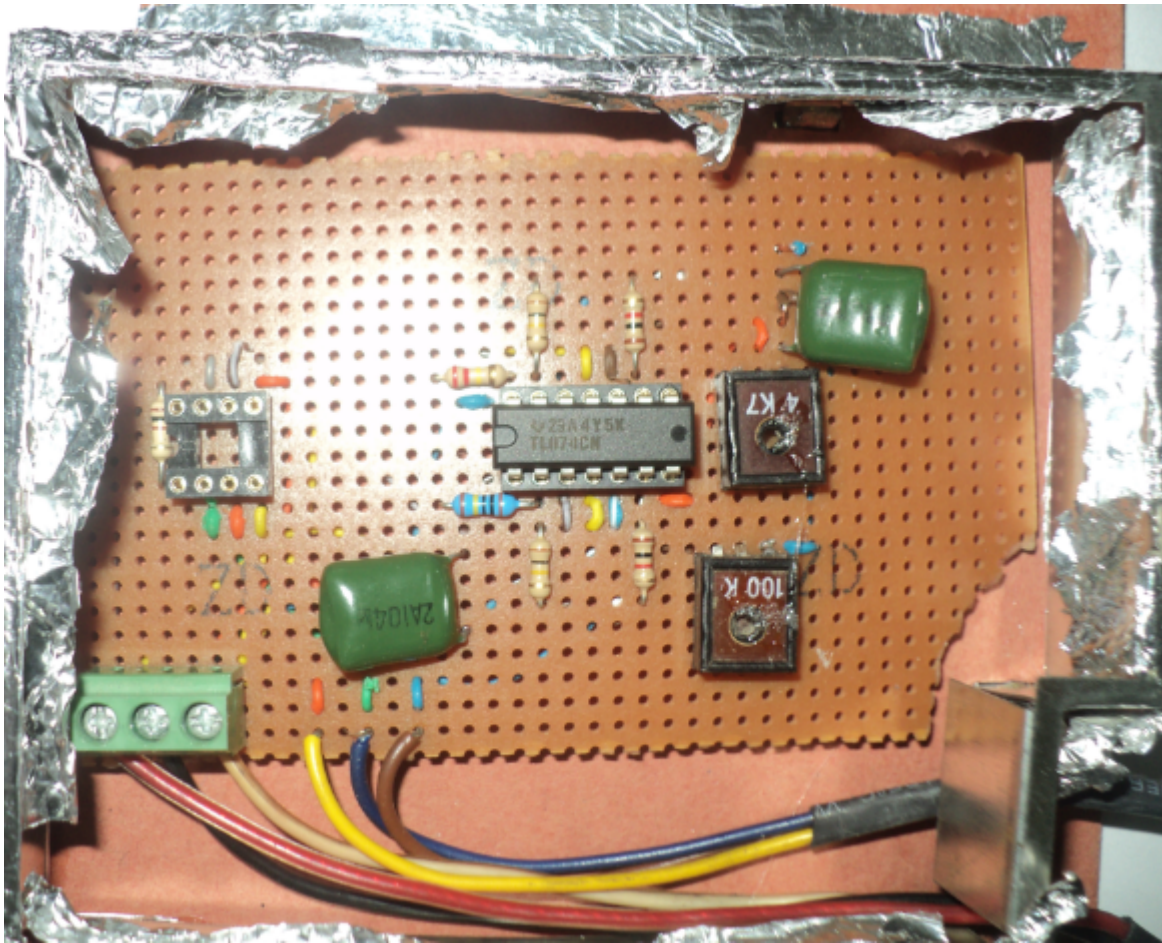

Fig.(3-32) EMG circuit

### Calculation

- the op-amp circuits are supplied with 18 v by battery .
- Calculation the magnitude of the gain for AD620 amplifier ,shown in Fig.(3-33) :

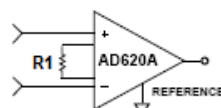

Fig. ( 3-33) AD620

- gain for AD620 is calculated using the following equation :

$$\text{Gain} = \frac{49.4K\Omega}{R_1} + 1$$

$$A_{V1} = 310$$

$$\frac{49.4K\Omega}{R_1} + 1 = 310$$

$$\therefore R_1 = 160 \Omega$$

- stage of high pass filter shown in Fig.(3-34) [34] :

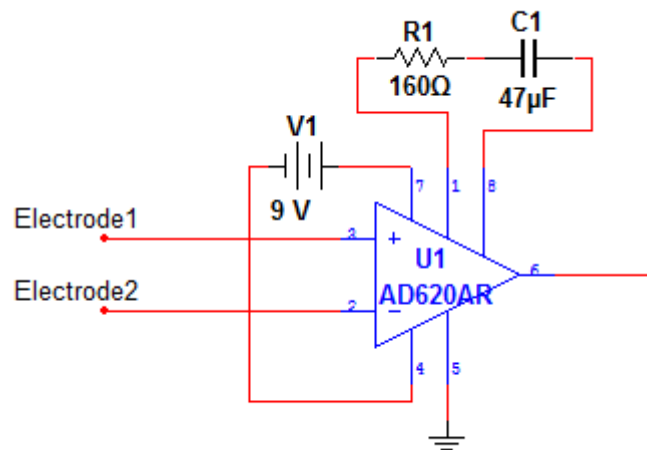

Fig. ( 3-34 ) high pass filter

critical frequency FL of (HPF) is calculated using the following equation :

$$F_c = \frac{1}{2\pi * R_1 * C_1} \quad \text{Equation(3-5)}$$

$$\text{Let : } C_1 = 47\mu\text{F}$$

The critical frequency is equal 20Hz ( $F_c = 21 \text{ Hz}$ )

$$\therefore R_1 = 160\Omega$$

- stage of inverting amplifier shown in the Fig.(3-35) [35] :

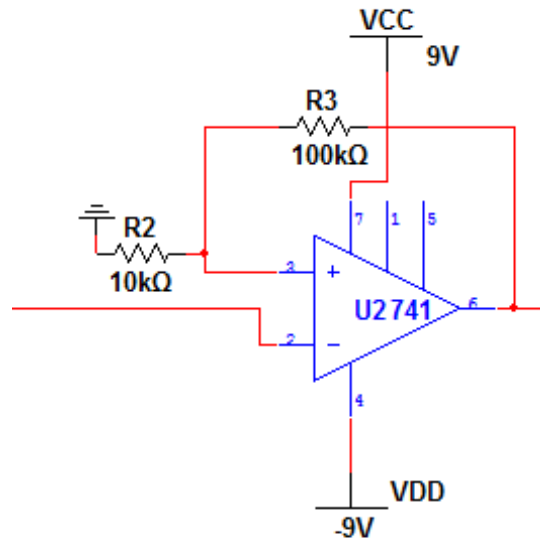

Fig. ( 3-35 ) Inverting amplifier

gain is calculated using the following equation :

$$A_v = 1 + \frac{R_3}{R_2}$$

Assume that :  $A_v = 10$

Let  $R_3 = 100k\Omega$

$\therefore R_2 = 10k\Omega$

- The 555 timer Monostable Circuit is shown in Fig.(3-36) below [36] :

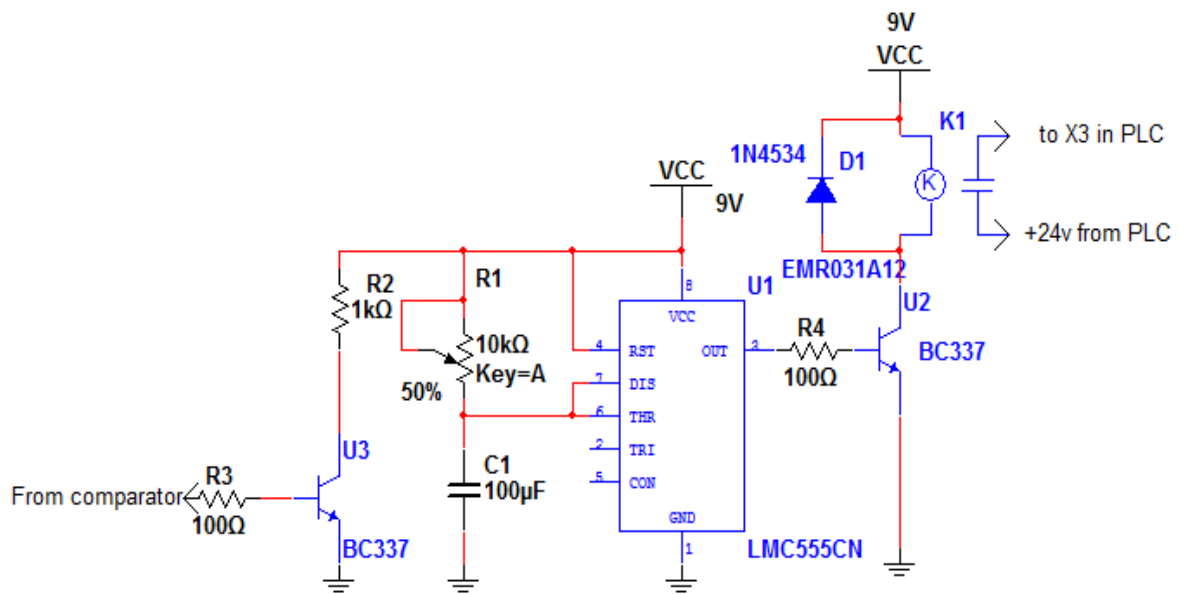

Fig.(3-36) The 555 timer Monostable Circuit

The values of components(R1 and C2) determine the length of time that the monostable output is in the high state.We will need to adjust the time period of the monostable circuit to 1 second by using the equation below :

$$T=1.1RC$$

Equation ( 3-6 )

Then we need time equal 1 second

$$1=1.1 * C1 * 10k\Omega$$

$$\therefore C1 = 100\mu F$$

- Transistor (U2) NPN type as shown in Fig.(3-37) used as switch to operate relay

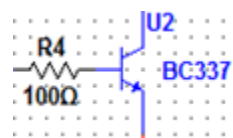

Fig.(3-37) NPN transistor

Resistor (R4=100Ω) is often needed in series with the base connection to limit the base current  $I_B$  and prevent the transistor being damaged.

### 3.6.2 Stimulator Circuit Design

#### 3.6.2.a Waveforms For The Signal

Different waveforms produce different contraction intensities and different levels of fatigue. The waveform is an important consideration in the choice of an appropriate muscle stimulation regimen. Two basic criteria are used to evaluate the appropriate stimulation waveform:

- 1) Amplitude of the signal.
- 2) Frequency of the signal

#### 3.6.2.b Block Diagram of an Equipment For Electrotherapy :

block diagram of the proposed device shown in Fig.(3-39)

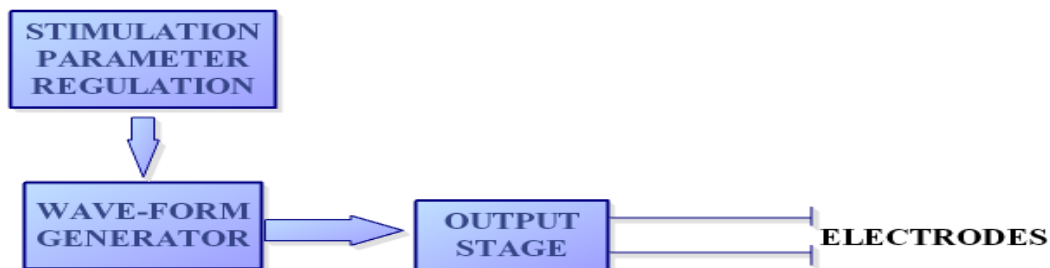

Fig.(3-39) Block diagram of electrotherapy

Usually it is possible to select :

- 1) The voltage or current wave form applied to the patient by means of skin electrodes.
- 2) The parameters of this wave form.

#### Timing

We Apply frequency of 86 Hz on the muscle to be stimulated, we control in parameter through variable resistors like :

- 1) Pulses with frequency variable with continuity in a fixed range.
- 2) Pulses with amplitude variable with continuity in a fixed range.

### 3.6.2.c Circuit design

shows the circuit of EMS in Fig.( 3-40) [37] .

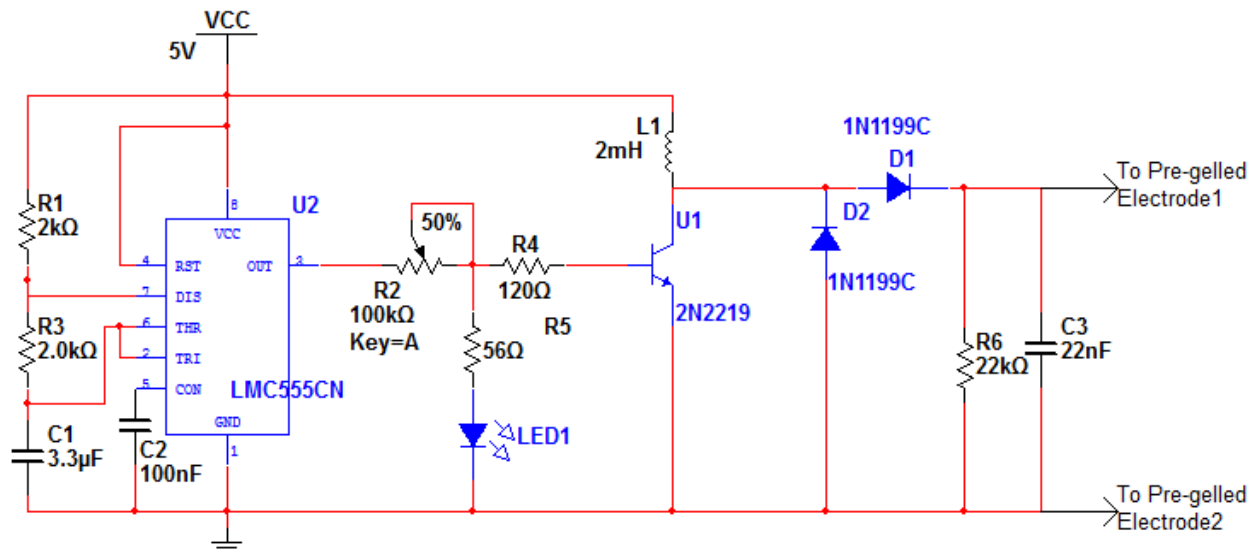

Fig. ( 3-40 ) Circuit of The EMS

#### Description:

The out put signal from This circuit has the desired frequency and high voltage and produces pulses that can stimulate muscle. The signal generator is the 555 timer IC that produces pulse with 86Hz of frequency. Astable mode is designed to give frequency values for the 555 timer, based on the control capacitance and resistance(R1&R3&C1).5V is step up to higher voltage but a very low current. Potentiometer R2 controls the output voltage. LED intensity indicates the output state, normal light when output is high and totally off when output is low.C3 adds more "sting" effect on the circuit, increasing its value increases its sting.Diode D2 protects the transistor from voltage spikes.

#### Calculation:

we need a specific frequency equal 86Hz to run the circuit as stimulator circuit the equation to determine the desired frequency is :

$$\text{Frequency} = 1.44 / ((R1 + 2R3) * C1)$$

Equation ( 3-7 )

Suppose the resistor (R1=2KΩ and R3=2KΩ)

Then we calculate the value of C1

∴  $C1=3.3\mu F$

Circuit which we built shown in Fig.(3-41)

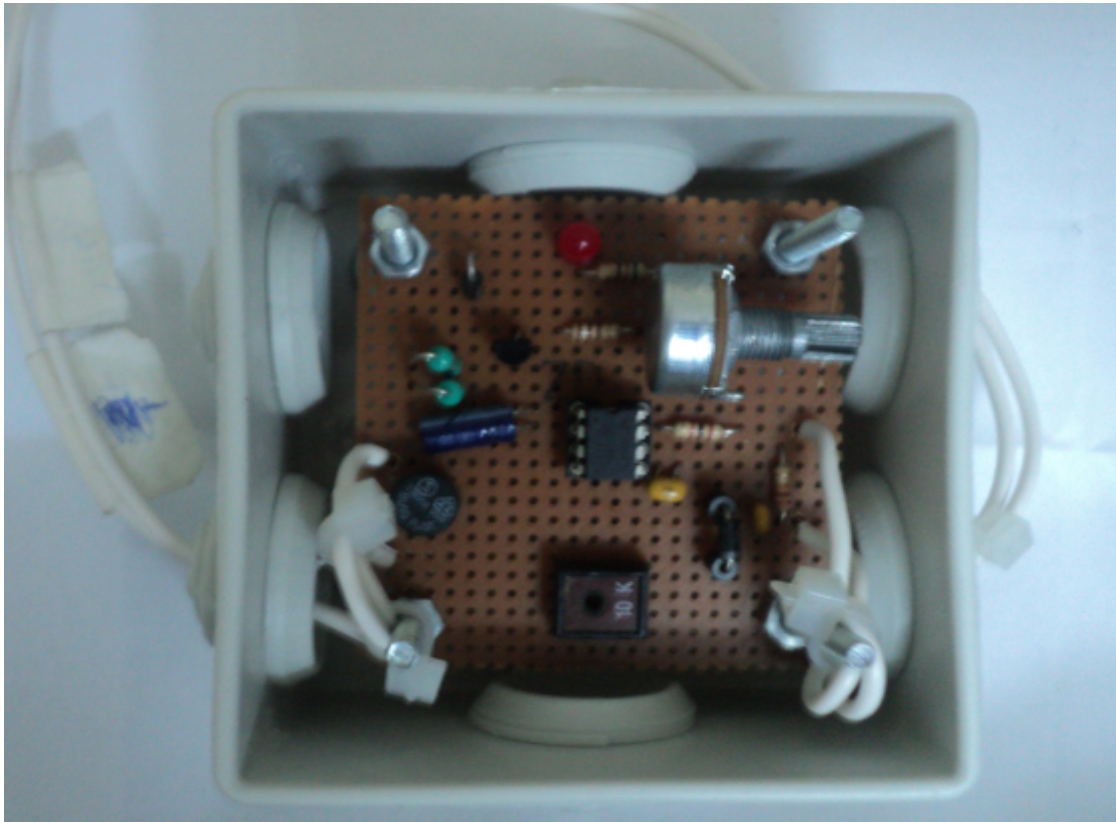

Fig.(3-41) EMS circuit

## Electrodes

Electrodes are used to transmit the electrical current to the body and can be referred to as electrical conductors. The electrodes are the point of contact where the current that is produced by the electrical stimulation unit reaches the body. Depending on the modality used, electrodes can stimulate the surface of the skin or can be used to stimulate the deep muscle, tendon and ligament tissues. The electrodes should be durable so that they can be utilized repeatedly over a long period of time. In addition, they must be flexible so that contact with the uneven skin surface is maintained even when the skin flexes during contractions. Due to the possibility of sensitivity to latex, the electrodes should be latex free.

## Electrode Connection Options

There are electrode contacts with the body that are used to carry the current to the treatment site. Most common contact is to place the electrodes directly on the surface of the skin. This type of electrode is called transcutaneous, which simply means “on the surface of the skin. [38]

### **A Good Contact Between The Skin And The Electrode Is Made By:**

- 1) Wetting the skin and contact surface of the electrodes.
- 2) Wising a non-conductive lubricating jelly between the skin and electrode.
- 3) Hair can be removed from under the electrode, through clipping not shaving.

### **Electrodes which is used in project :**

Pre-gelled : as we see in the Fig. ( 3-43 ). The best quality of pre-gelled electrodes has 4 layers including; topical material, conductive silver, conductive carbon film and gel. In comparison with other commonly used electrodes, pre-gelled electrodes in general produced:

- Lower torque
- Higher electrical impedance
- Produced the most skin reactions
- Easiest to apply



Fig. ( 3-43 ) Pre-gelled electrode

### 3.6.3 Heart Rate

#### 3.6.3.a Block Diagram

shows the block diagram of the proposed device in Fig.(3-44).

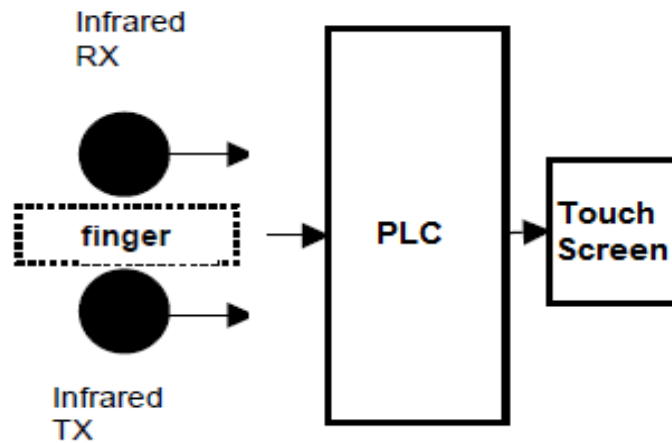

Fig.(3-44) Block diagram

project describes the heart rate of the body by clipping sensors on one of the fingers and then displaying the result on a text based touch screen .The device has the advantage that it is PLC based and thus can be programmed to display heart rate continuously .Basically, finger sensor consists of transmitter (LED) and an sensor photo-cell. The transmitter-sensor pair is clipped on one of the fingers of the subject (see Fig. ( 3-45 ).

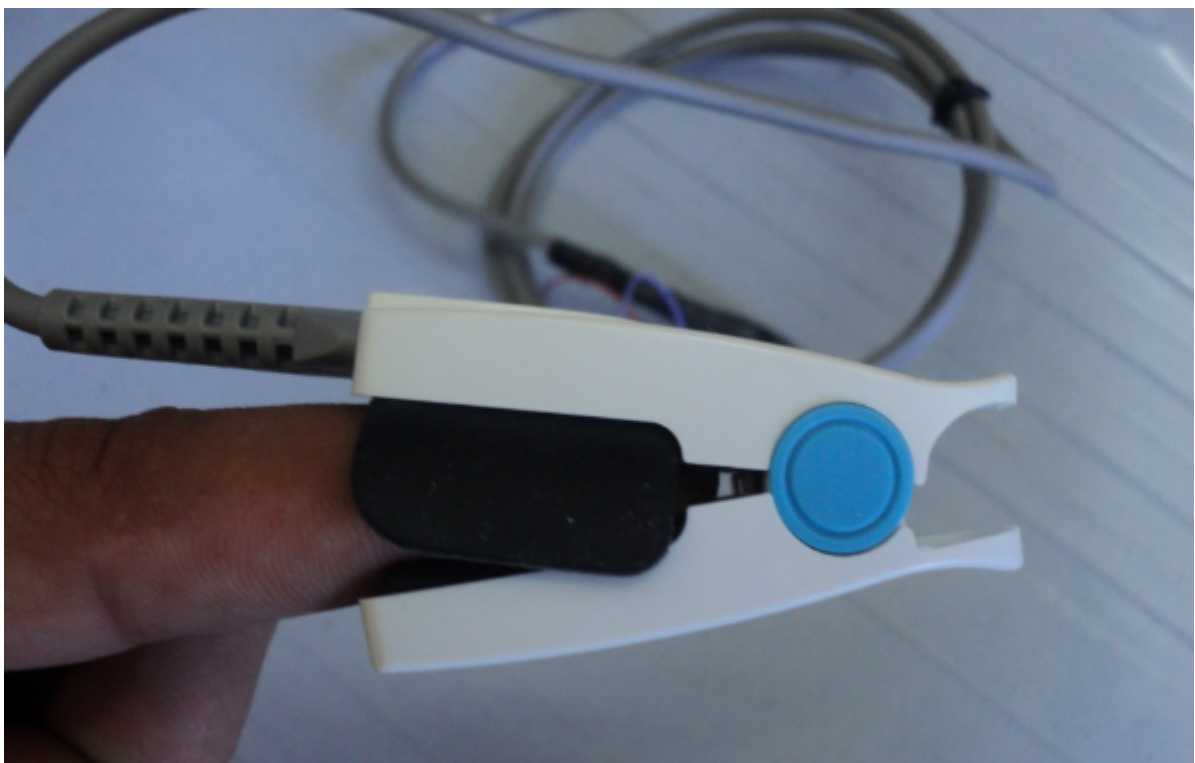

Fig. ( 3-45 ) photocell transmitter and received sensor

The LED emits light to the finger of the subject. The photo-cell detects this light beam and measures the change of blood volume through the finger artery .and is fed to a PLC for analysis and display. The PLC counts the number of pulses over a fixed time interval and thus obtains the heart rate of the subject. Several such readings are obtained over a known period of time and the results are averaged to give a more accurate reading of the heart rate. The calculated heart rate is displayed on an touch screen in beats-per-minute [39] .

**3.7 The Automation Part**

**3.7.1.a Motors Driver Circuits :**

permanent magnet DC motor controller :

PM-DC Motor speed control from change the motor input voltage below the nominal voltage using the DC-DC converter "Buck chopper circuit " Fig.(3-46)

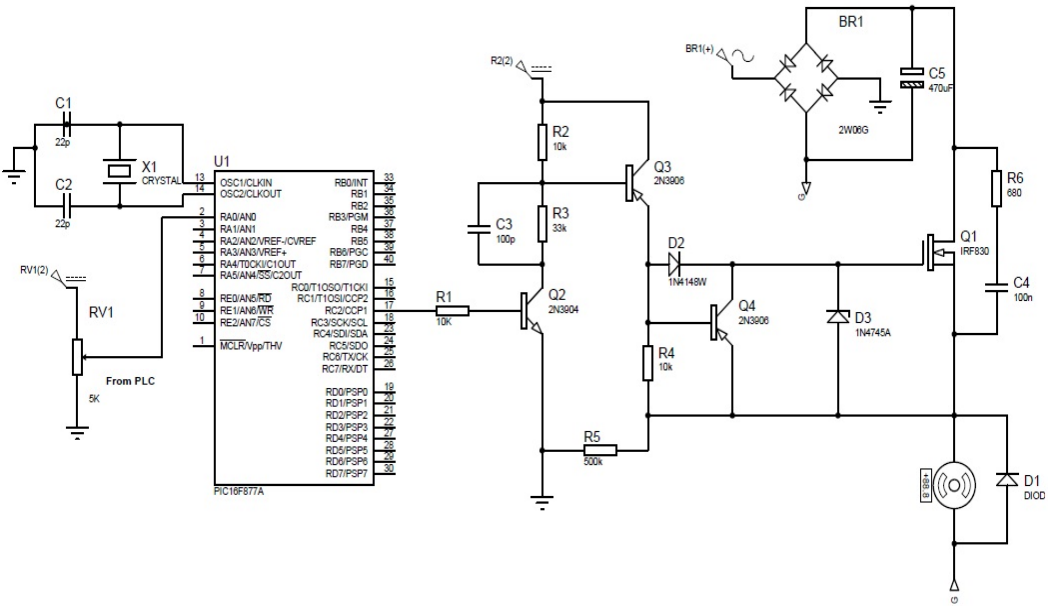

Fig(3-46) chopper circuit

Circuit picture which we built shown in Fig.(3-47)

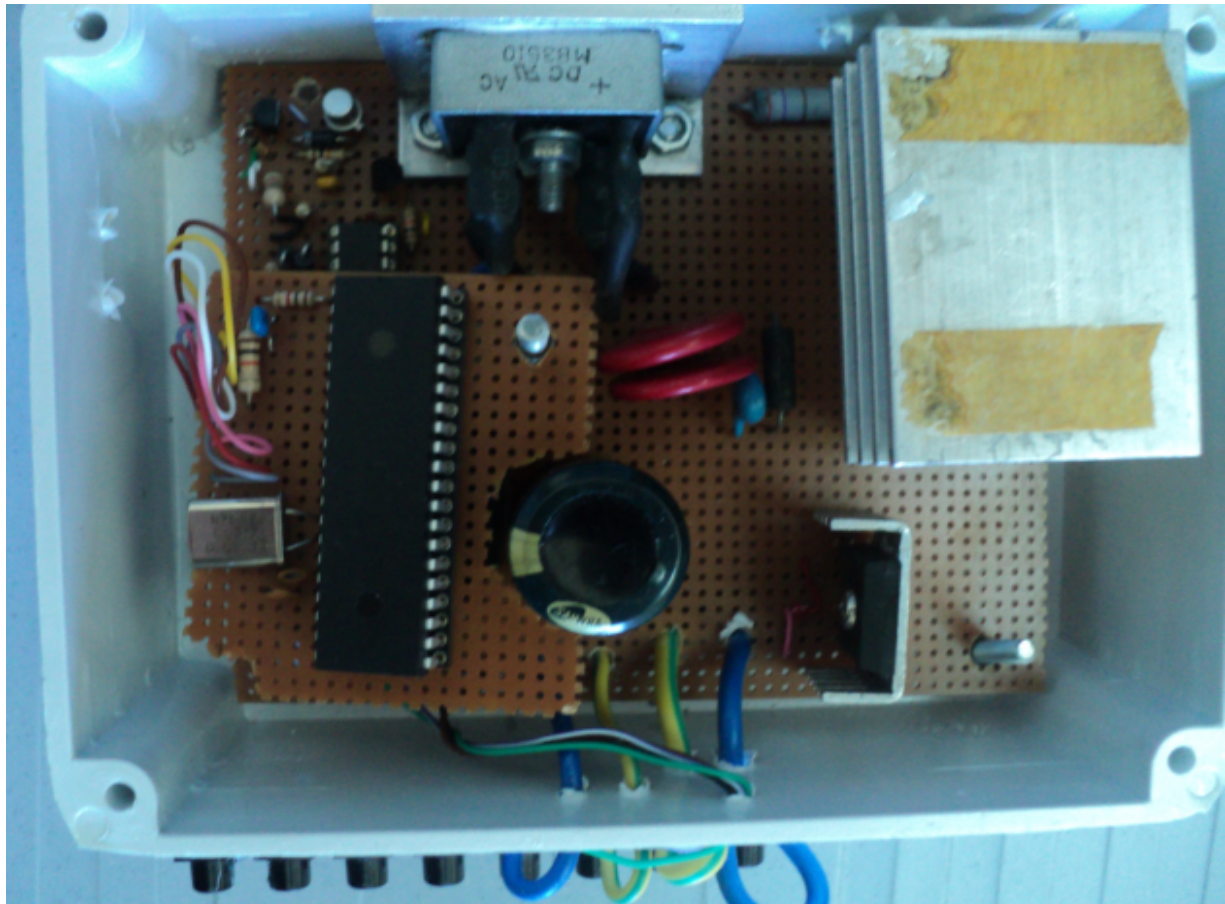

Fig.(3-47) chopper circuit

DC-DC converters are power electronic circuits that convert a DC voltage to a different DC voltage level. The Buck ( Step-Down ) Converter is a one type from a chopper circuit, this type controlling the DC component of a pulsed output voltage use *Pulse-width modulation* (PWM) control signal. The circuit in Fig(3-46) use PIC Microcontroller to generate variable PWM refer to PLC output voltage (Analog output) , the Microcontroller used because small size and low cost, the type of this microcontroller is PIC16f877A selecting because the (A0) analog port to take the analog voltage from PLC analog module and change the motor speed via change the PWM Duty-Cycle .

Chopper output voltage depend the PWM duty-Cycle "D" show Fig(3-48), the following equation describe this relation :

$$\text{Duty-Cycle} = \frac{t_{on}}{T} \quad \text{Equation (3-8)}$$

$$V_{out} = D \times V_s$$

where :

$t_{on}$ : vale of the signal is active high.

T : the period of the signal .

$V_{out}$ : output voltage (Motor source)

$V_s$ : supply voltage after rectification and filtration.

D : Duty –Cycle

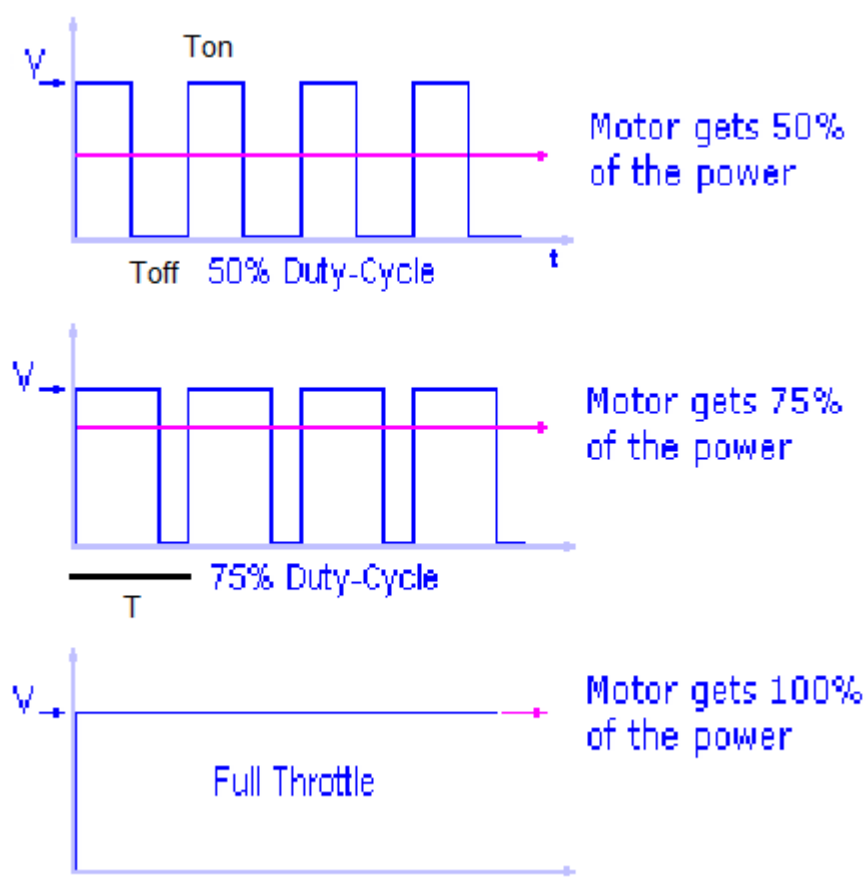

Fig.(3-48) Chopper output voltage

**Circuit Description :**

AC-DC Converter (uncontrolled full wave Rectifier):

The input voltage 220V/50 Hz connect with AC terminal in Bridge Rectifier (10A /1000V PIV) ,after bridge connect the polarity capacitor (220 $\mu$ f /400V) to filtering the DC voltage and decreasing the ripple and go to full peak value, the flowing equation describe this process :

$$V_{peak} = V_{rms} \times \sqrt{2} , \quad \text{Equation (3-9)}$$

$$I_{peak} = I_{rms} \times \sqrt{2} \quad \text{Equation (3-10)}$$

AC –DC converter process also can be show in the Fig.(3-49)

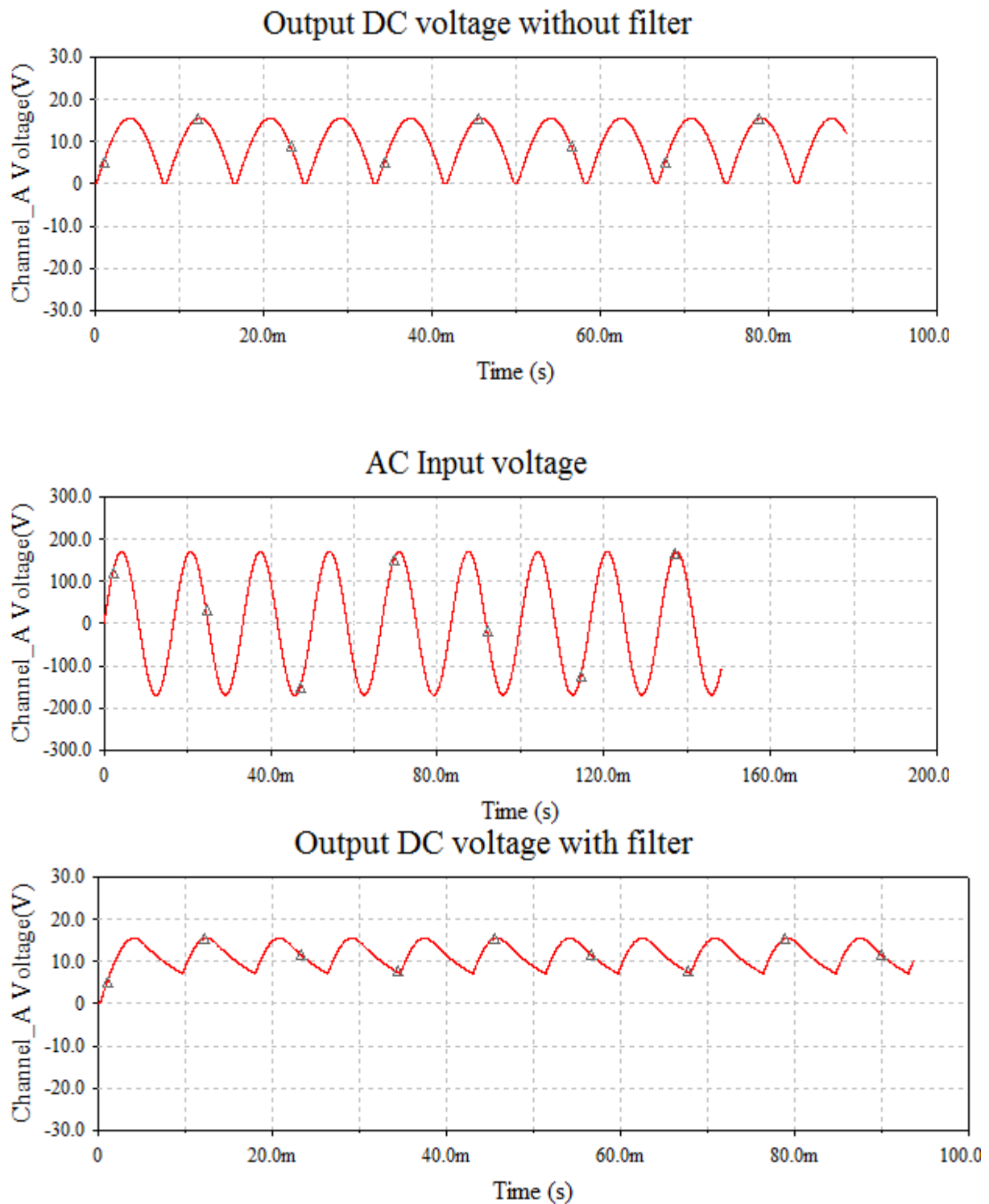

Fig.(3-49) AC-DC converter wave forms

DC-DC Converter (main chopper circuit):

The power side in chopper circuit after Rectifier consist of the following element Fig.(3-50) :

- MOSFET Transistor
- RC Snubber circuit
- Virstor

- Fast Recovery Diode (freewheeling Diode)

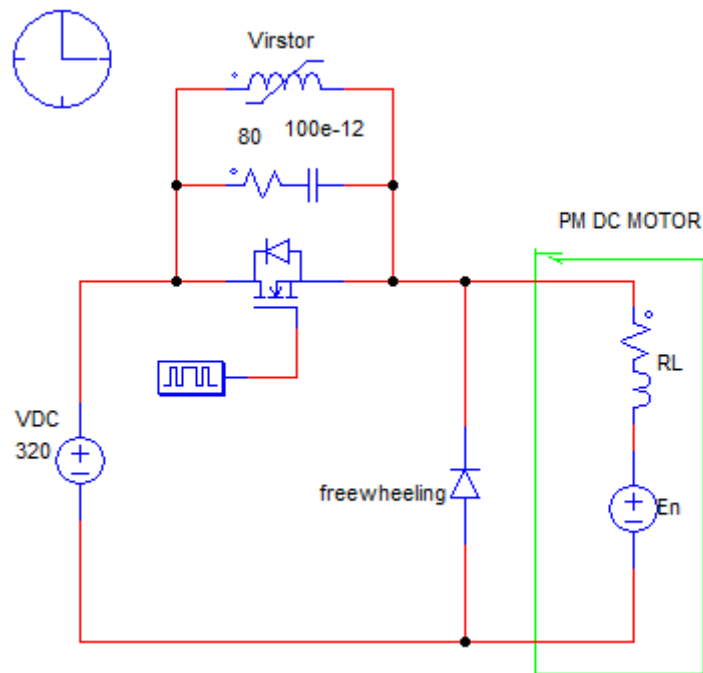

Fig.(3-50) DC-DC convertor

- 1- MOSFET is a transistor used for amplifying or switching electronic signals. Although the MOSFET is a four-terminal device with source (S), gate (G), drain (D), and body (B) terminals, the body (or substrate) of the MOSFET often is connected to the source terminal, making it a three-terminal device like other field-effect transistors .shown in Fig.(3-51)

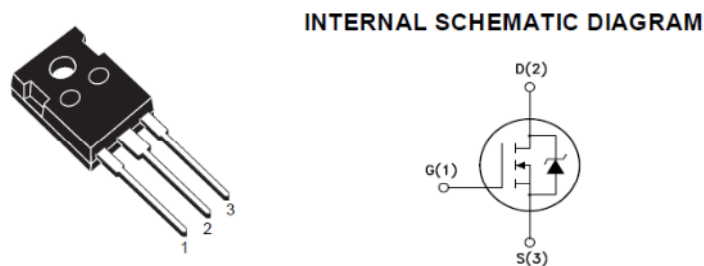

Fig.(3-51) MOSFET

In the upper circuit the MOSFET (Q1) Type is (IRFP460) , it's max current = 20A and max voltage = 500V and Gate voltage (15-20V)

- 2- the main Target from Snubber circuits is reduce power losses in transistors during switching and protect them from the switching stresses of high voltages and currents. Snubber circuit consist from R and C connection in series and value of R&C depend on switching

frequency and the voltage across the MOSFET and the current flow it, The flowing equation describe the snubber calculation [40] :

$$C = I_{peak} \times \frac{di}{dv} , \tag{Equation (3-11)}$$

$$R = \frac{1}{f * C * 20} ,$$

In upper circuit : R6= 80 ohm /2W , C4 = 100PF / 1000V , Switching frequency generate from PIC is 10KHz

4- The Virstor is an electronic component with a "diode-like" nonlinear current–voltage characteristic. Varistors are often used to protect circuits against excessive transient voltages by incorporating them into the circuit in such a way that, when triggered, they will shunt the current created by the high voltage away from the sensitive components, its shown in Fig.(3-52)

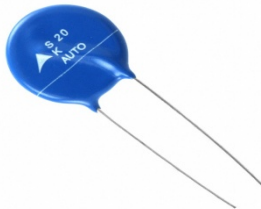

Fig.(3-52) Virstor

Max. voltage for varistor = 450V , and this voltage is bigger than nominal voltage in circuit and less than mosfet rating voltage. freewheeling diode is a diode used to eliminate flyback, the sudden voltage spike seen across an inductive load when its supply voltage is suddenly reduced or removed, in our chopper circuit we use two freewheeling diode : D1 for motor ( PM-DC ,  $I_{motor(max)} = 13A$ ) its fast recovery diode with a parameters 40A / 100V , D3 for mosfet its 10A / 600V .

5- freewheeling Diode :The free wheeling diode has a unique function in the circuit. It ensures that the output voltage during each "off" time, allotted by the MOSFET, is equal to 0 V. It achieves this by acting as a sink for the motors internal inductance. That is, when the MOSFET stops conducting, the current stored in the motor's inductance discharges itself through the motor and the diode. The observed effect is that the motor continues operation despite drawing no current from the source Fig.(3-53) [41] .



Fig.(3-53) freewheeling Diode

### **High side MOSFET Gate Driver :**

High-side gate drivers are used to drive a MOSFET or IGBT that is connected to the positive supply and is not ground-referenced but is floating. High-side drivers are more complicated than low-side drivers because of the required voltage translation to the supply and because it is more difficult to turn off a floating transistor.

When Q2 turns on, it drives Q3 on, which drives the power MOSFET (Q1) gate. Gate turn-off is accomplished by the floating PNP, Q4, which is driven on (once Q3 is off) by the voltage across the gate-source capacitance, through R4. Diode D2 is off during turn-off. This circuit has an advantage over the inverting driver in that the output circuit driving the gate is floating, isolated by the collector of Q3. Consequently, for motor-drives, no reverse current path from output through Zener D3 exists. At power-on, a conduction path through the collector of Q3 can be thwarted if problematic by placing a diode in series with the Q3 collector.

Closed loop control system :

This controller design in closed loop control system with feedback from encoder to make sure the constant speed of treadmill and soft start of the treadmill motor .

PID controller and closed loop system is built in PLC and the output of this stage connect in the PIC microcontroller to change the PWM and change the speed of the motor refer to the closed loop commend.

The closed loop system can be show in the Fig.(3-54) ,and the some of result the chopper circuit and motor drive Show in the Fig.(3-55).

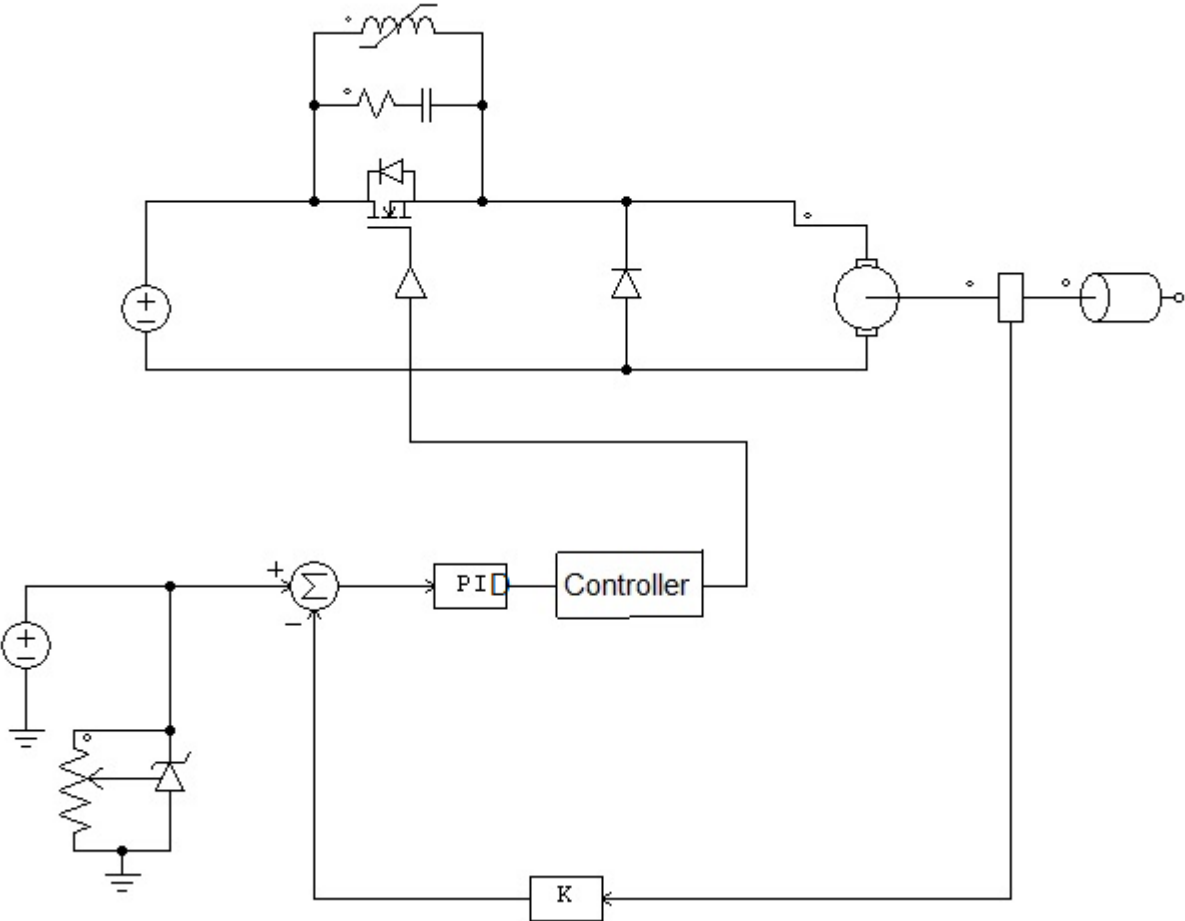

Fig.(3-54) PID controller

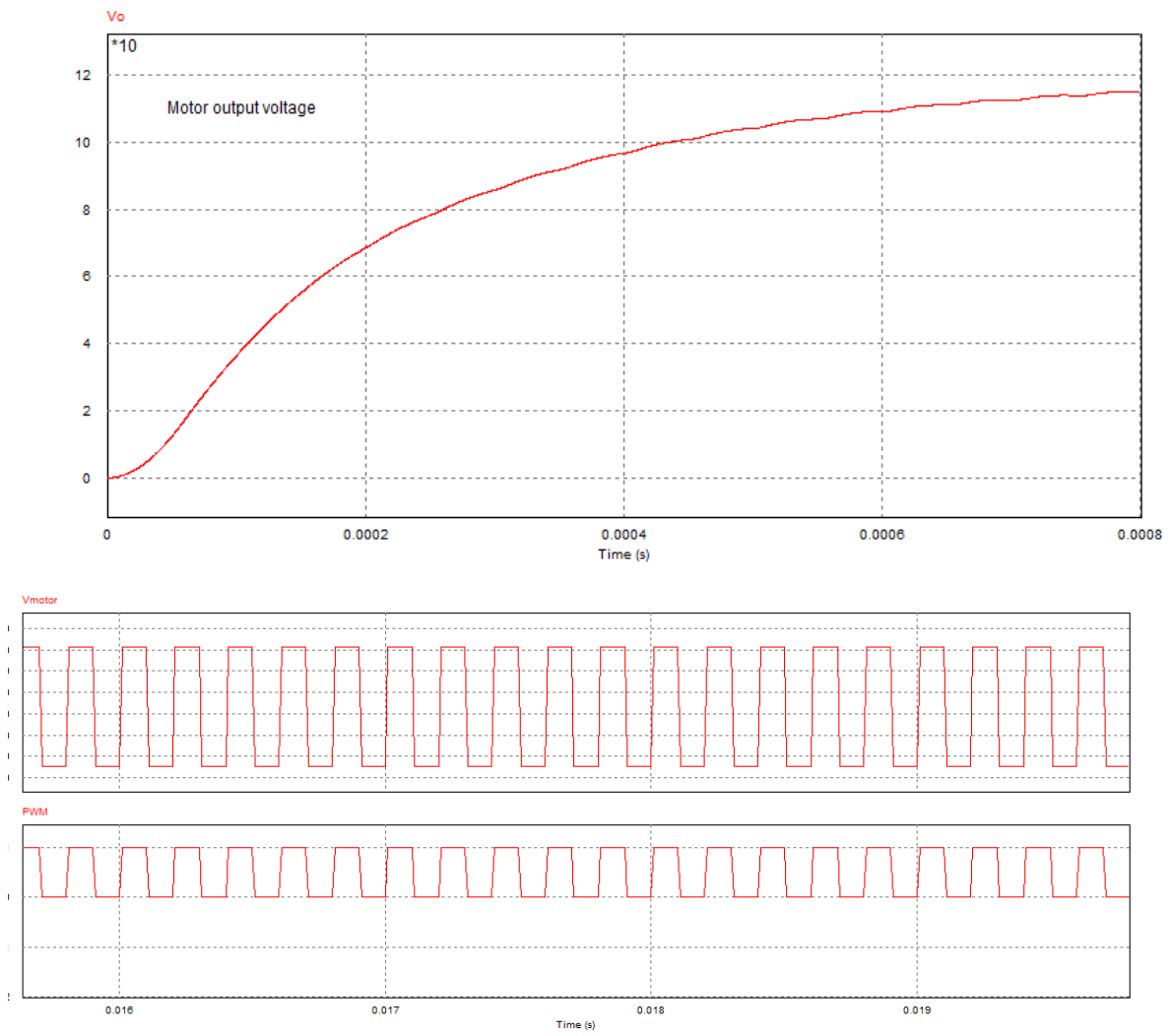

Fig.(3-55) motor output voltage

**3.7.1.b 3-ph squirrel cage IM controller shown in Fig.(3-56)**

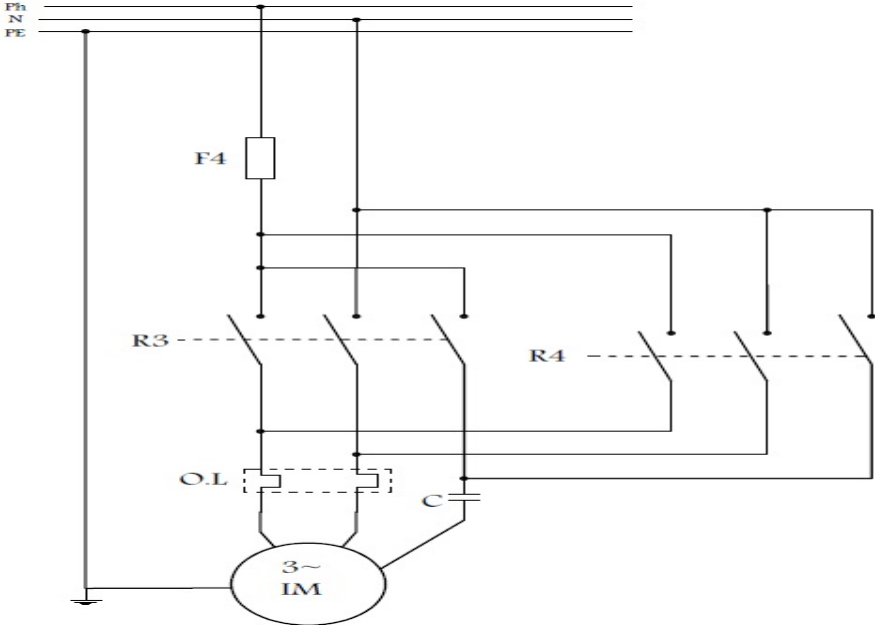

Fig.(3-56) 3-ph squirrel cage IM

Contactors ( R3 ) and ( R4 ) are programmed inside PLC to reverse the direction of 3-ph squirrel cage IM rotation.

**3.7.2 control panel**

**3.7.2.a Programmable logic controller PLC**

PLC that used is Delta , with model DVP-20EX , it's contain 8 digital input ,6 digital output , 4 analog input and 2 analog output , choosing this model is based upon containing internal extension module that give analog inputs and outputs needed for sensors used in project.

There are four analog sensors : load cell , tension sensor , accelerometer and position sensor , The function of PLC in project is to take analog command from sensors , process it and give the appropriate decision based upon program save inside PLC .

PLC treat with orders step by step , every step is 20mv , and the analog signal in PLC is treated from -10mv to 0 , and from 0 to 10mv , but Tension sensor and load cell output voltage not reach the step voltage ( 20mv ) , then to connect these sensors with PLC we need to enlarge the sensors output voltage , this done by using instrument amplifier ( AD620 ) as shown bellow

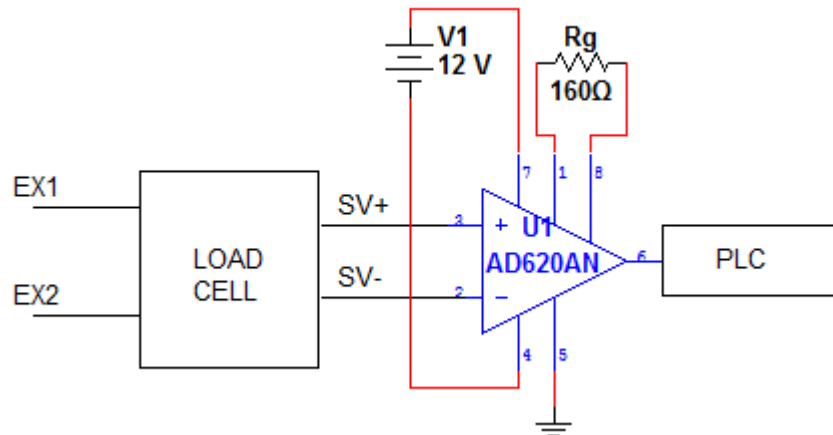

Fig.(3-57) AD620 connections

position sensor output voltage is between  $-0.3\text{ mV}$  and  $0.3\text{ mV}$  and that need to enlarge , that done by using non inverting amplifier it's gain is 10 .and so for accelerometer we need a non inverting amplifier circuit with gain 10 to enlarge output voltage .

four sensors supplied with a DC voltage but with different values :  
 load cell :  $12\text{ Vdc}$  , position sensor :  $5\text{ Vdc}$  , Accelerometer :  $2\text{ Vdc}$  .

in control panel , PLC connected with switches and relays through digital input and output and with sensors through analog input and analog outputs .

### 3.7.2.b Touch Screen :

Model that used is delta DOP-AS35 , it's width is 3.5 " with 256 color .  
 It's function is that we can enter calibration through it and to make a display for many values .

Calibration that set by touch screen :

- 1) treadmill setting contain
  - speed setting
  - percentage of body weight on treadmill
  
- 2) biomedical calibration
  - switching on and off EMG circuit
  - switching on and off stimulator circuit
  - switching on and off heart rate circuit

Then give start command that convert controlling of winch from manual to automatic and go to display page to show :

- 1) display heart beat
- 2) body weight
- 3) percentage of body weight on treadmill
- 4) stimulator on or not
- 5)EMG on or not
- 6) muscles active or not
- 7) display treadmill motor speed
- 8) if an emergency condition happened , show what is it .

topology shown in Fig.(3-57)

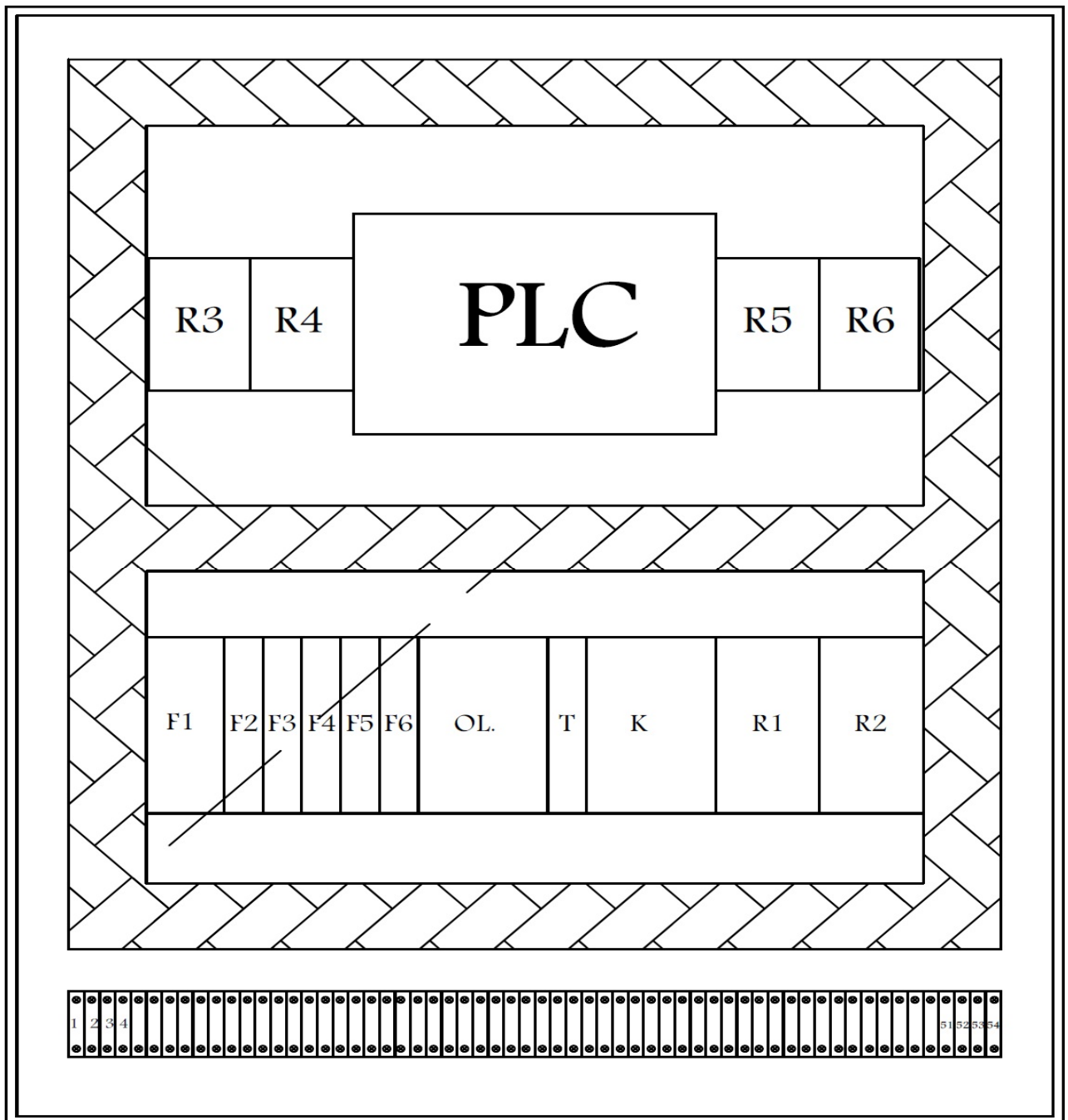

Fig.(3-57) control panel

## Description :

R3 and R4 : power relay 24v used for reversing the direction of rotation for induction motor .

PLC : programmable logic Controller , delta PLC ( DVP-20EX ) , .

R5 and R6 : control Relay , 24v .

F1 : 16A / 16KA phase neutral main switch .

F2 : 6A / 16KA switch for primary control panel .

F3 : 6A / 16KA switch for Delta PLC , display and secondary control panel .

F4,F5, F6 : 10A fuses for motors ( PM –DC , induction motor , servo dc motor )

OL : overload for induction motor .

T : on delay timer to increase safety .

K : main Contactor to switch control panel .

R1, R2 : associate relay 220VAC , used for primary control panel .

Fig. (3-58) show the picture of the primary control panel which is built:

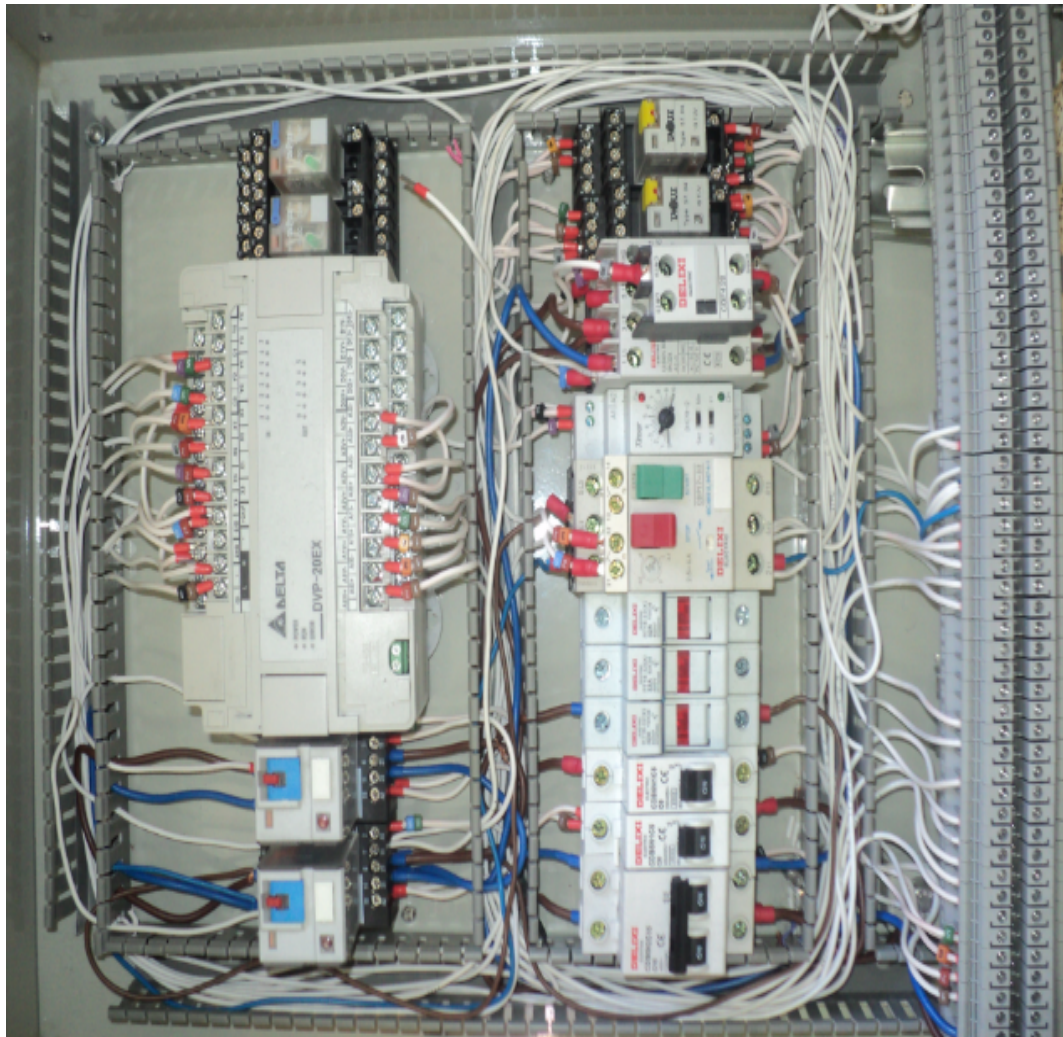

Fig(3-58) control panel



3.7.4 switching on / off control panel in Fig.(3-60)

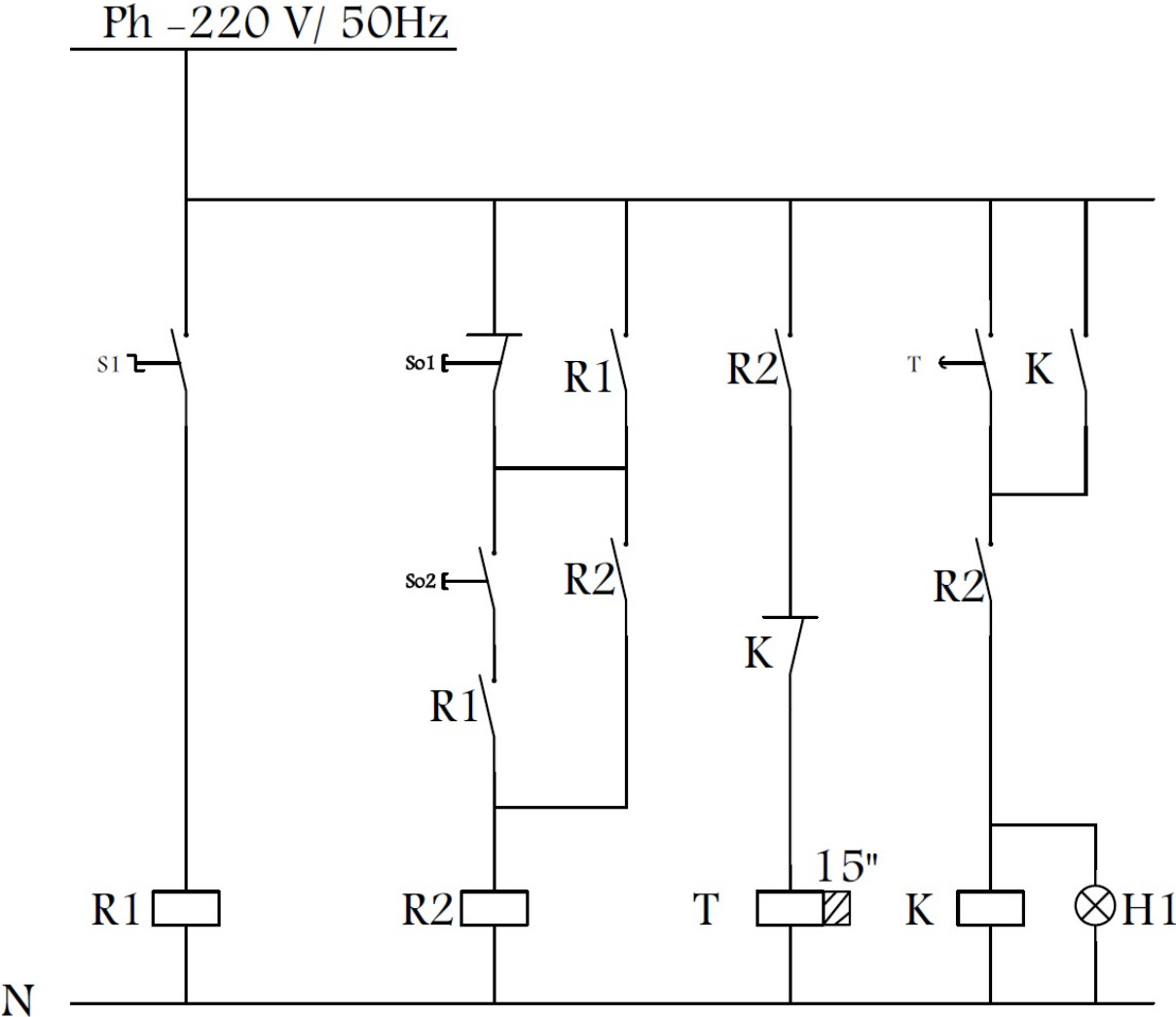

Fig.(3-60) switching on\ off control circuit

Switching ON :

When switch S1 ( select switch ) → R1 on  
 Then when switch So2 ( push button ) → R2 on → timer ( T ) on → after 15" → K on  
 To achieve sufficient protection by having enough time before switching on .

Switching off :

Switch off S1 → R1 off → open contactor R1  
 When switch So1 → R2 OFF → K off.  
 In order not allow any person switching off circuit except the specialist , also to achieve a protection for some devices such as PLC and touch screen from any problem in outer power circuit .

3.7.5 PLC connection shown in Fig.(3-61)

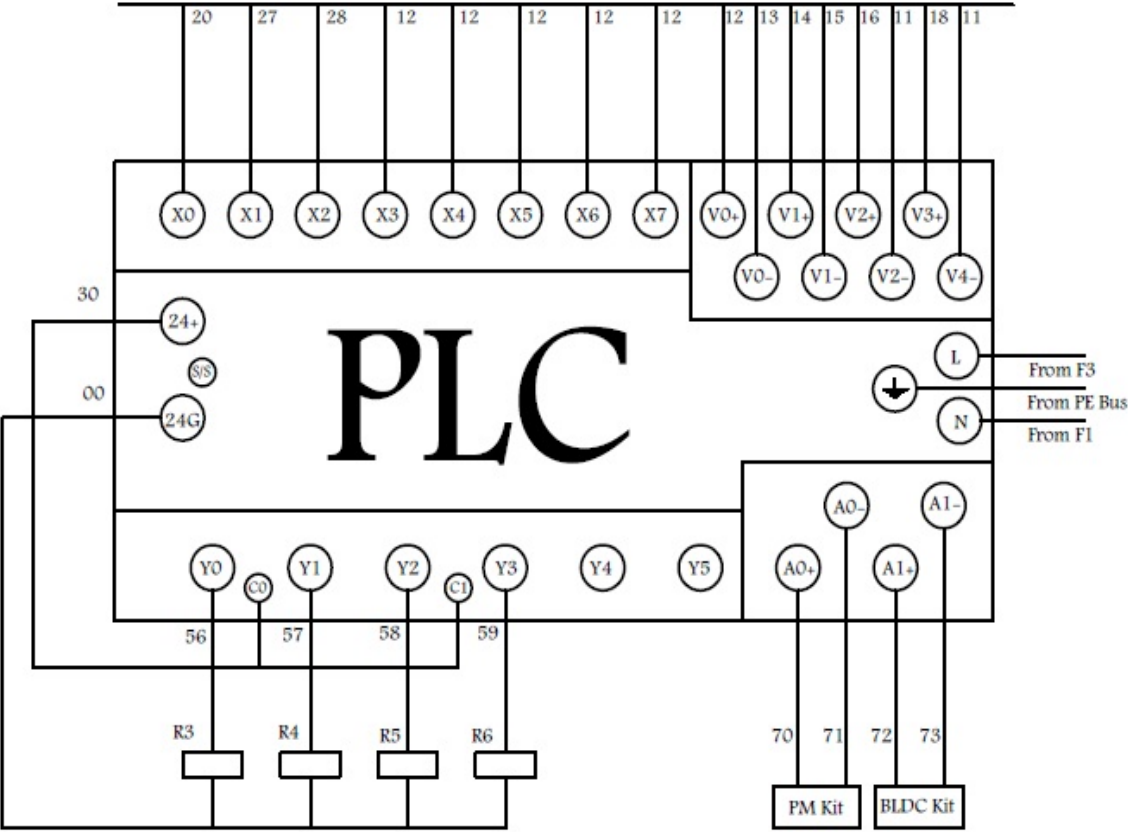

Fig.(3-61) PLC connection

X0 → X7 : digital input .

V0+ → V4- : analog input .

Y0 → Y3 : digital output .

AO+ → AI- : analog output .

Fig.(3-62) show the PLC which is built

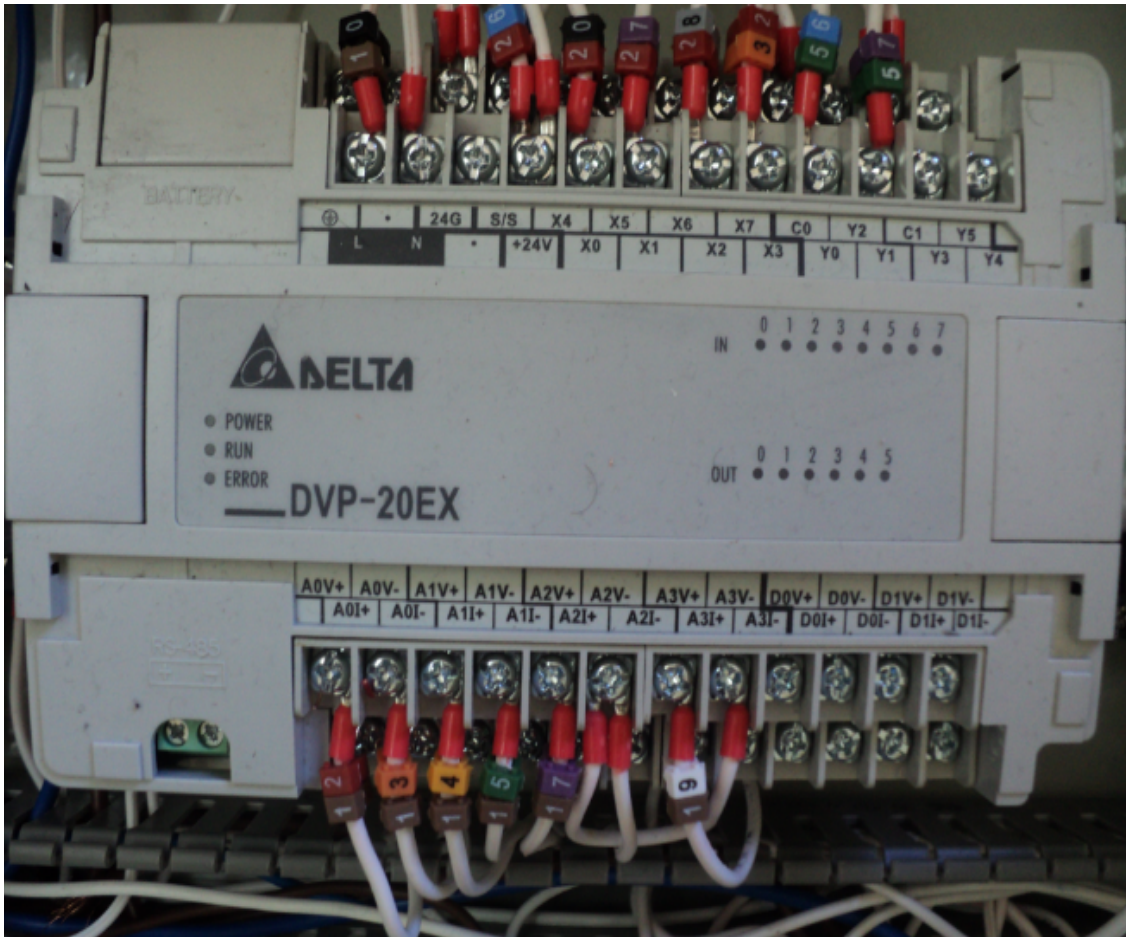

Fig.(3-62) PLC

### 3.7.6 Power circuit

#### 3.7.6.1 primary power circuit shown in Fig.(3-63)

Main power circuit :

F1 : 2 – poles , 16A / 6KA :

- main power switch

-used to protect circuit devices by cut electricity in short circuit and overload current.

F2 : 6A / 6KA switch to protect primary control circuit from short circuit and overload current .

K : second main switch to supply control panel that is located after primary control circuit .

F3 : 6A / 6KA switch to protect PLC , touch screen and other devices attached .

F4 : fuse to protect induction motor wires from overload and short circuit current .

F5 : 10A fuse to protect PM – DC motor controller .

R3 , R4 : used to reverse the direction of rotation of Induction motor .

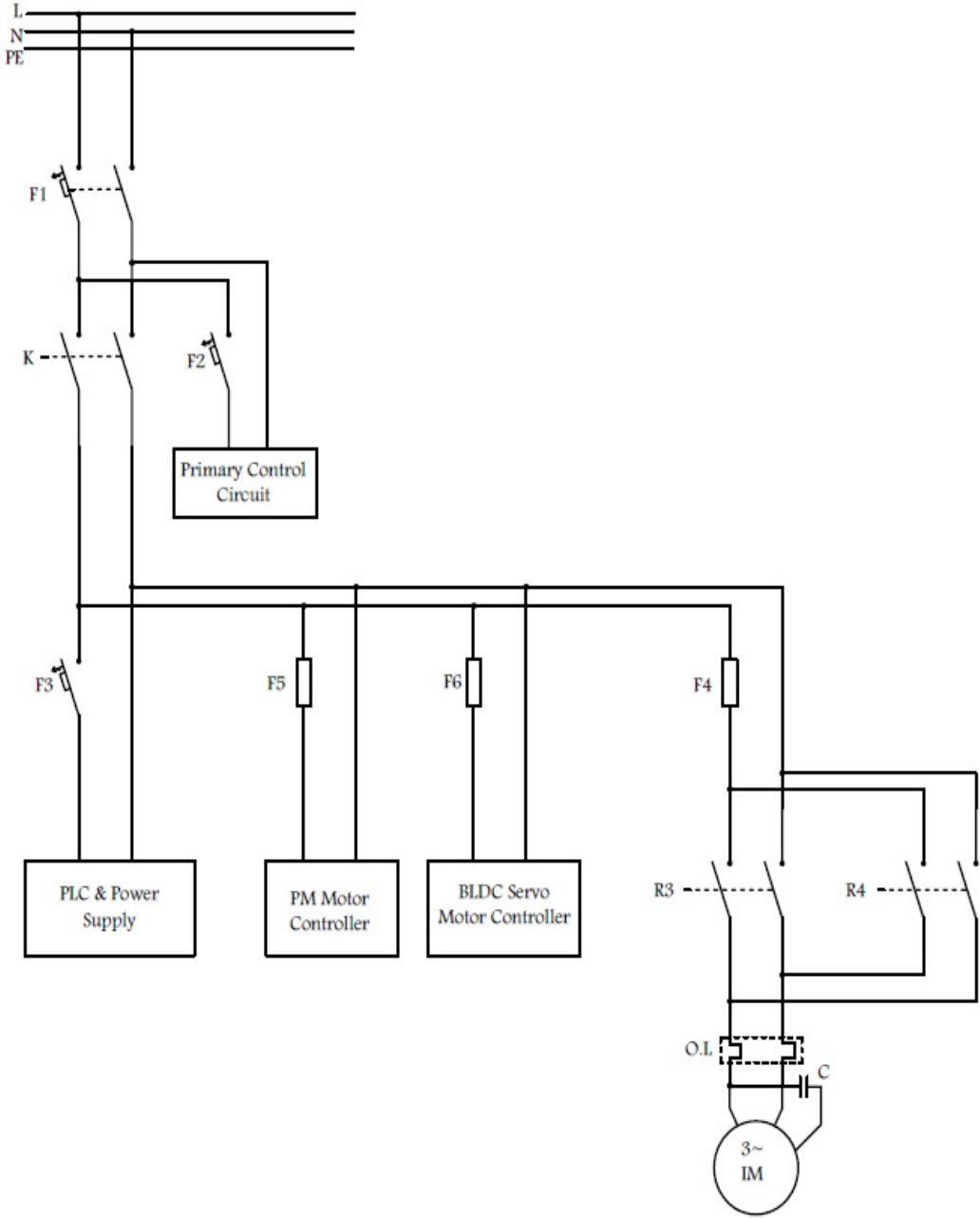

Fig.(3-63) primary power circuit

**3.7.6.2 power supply circuit in Fig.(3-64)**

DC power supply :

- 1)supply PM-DC motor controller with 24V
- 2)supply PM-DC motor controller with 5V
- 3)supply 12V and -12 V to stimulator circuit
- 4)supply 15V and -15 V to amplifiers circuits

- 5) 5V to supply position sensor and accelerometer
- 6) 12V to supply load cell and tension sensor

- Transformer ( T1 ) : step down transformer used to convert 220 Vrms to 24 Vrms
- Fuse ( F1 ) : protect components from short circuit current .
- Diode ( D1 ) : half wave rectifier for positive side
- Diode ( D2 ) :half wave rectifier for negative side
- C1 : smoothing positive half wave .
- C2 : smoothing negative half wave .

78xx : positive voltage regulator .  
 79xx : negative voltage regulator .

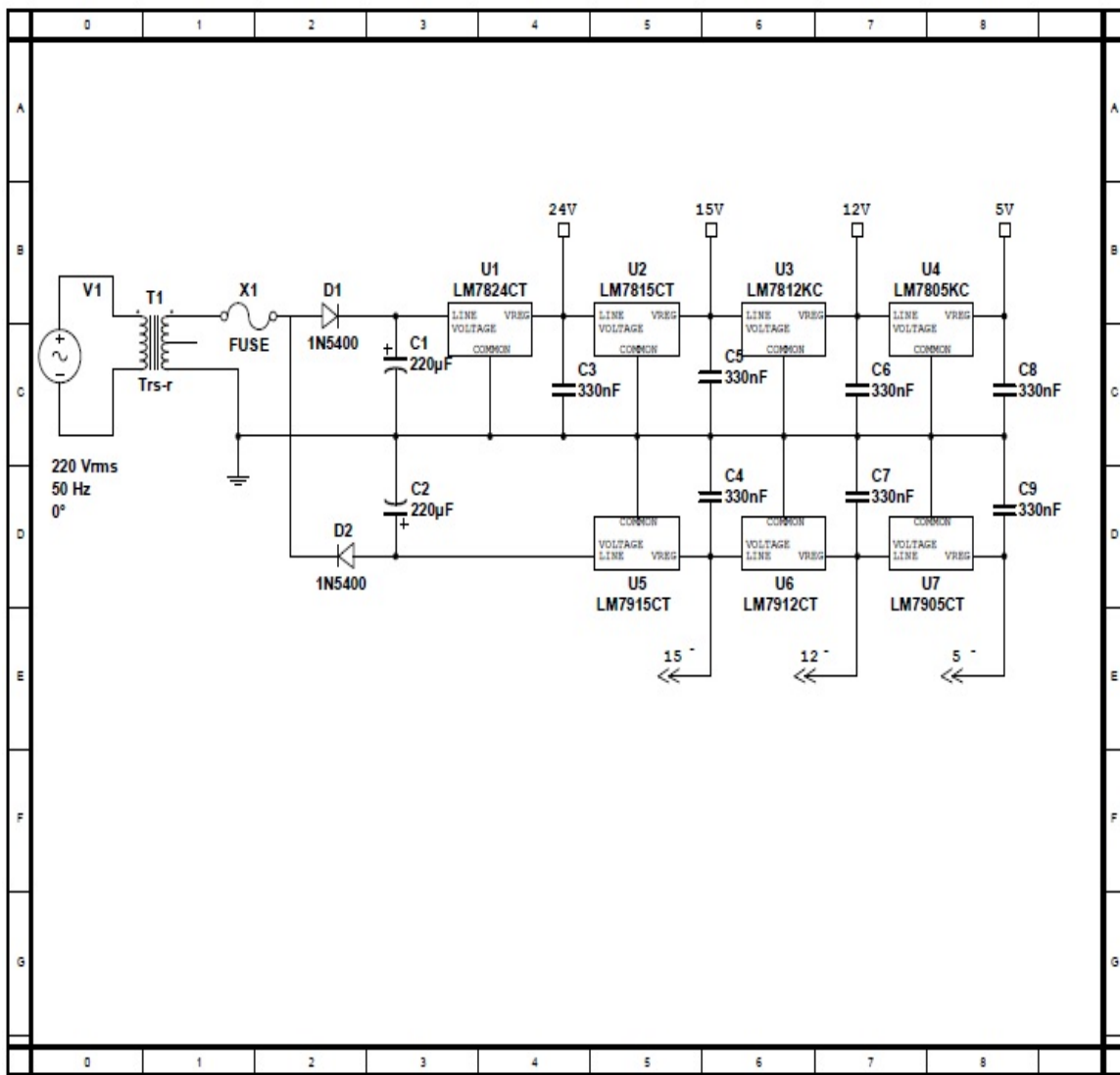

Fig.(3-64) DC power supply circuit

### 3.8 -Software

Programming :

#### 3.8.1 PIC Microcontroller Program :

The PIC microcontroller is the chip can be programming in many software support the PIC family, for example the "Micro – C " and MPLab , Flowcode Software .

PIC is used in chopper circuit to generate PWM and take the feedback from PLC to motor speed control , the software used to program PIC microcontroller is Flowcode software , this software dependent in flow chart list after this can generate the Hex file to download to PIC via programmable.

Now, can be describe the PWM code in the PIC16f877A in flowcode software :

- 1) The program Logo ; shown in Fig(3-65) :



Fig.(3-65) The program Logo

- 2) in flowcode the PWM is already function block, for this can be call this function and run it , the following PWM program, show Fig.(3-66) :

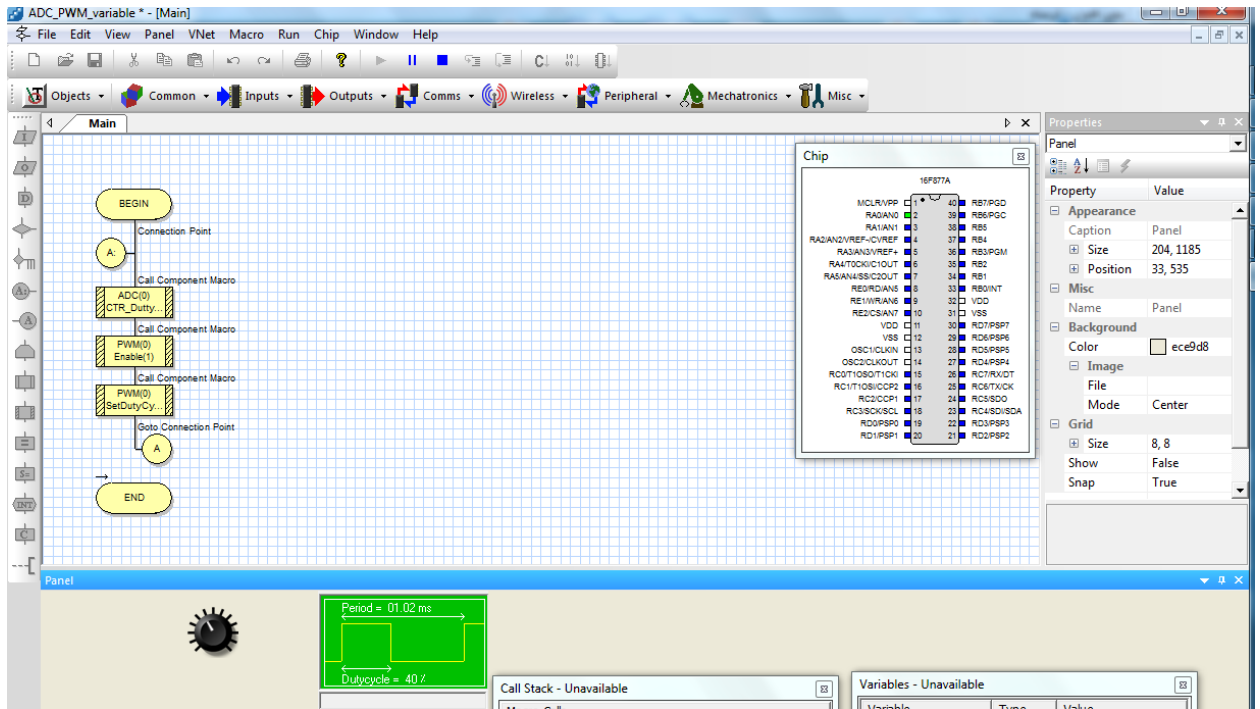

Fig.(3-66) flowcode the PWM

3) Now, the download step PIC via programmable Kit K150 show Fig.(3-67).

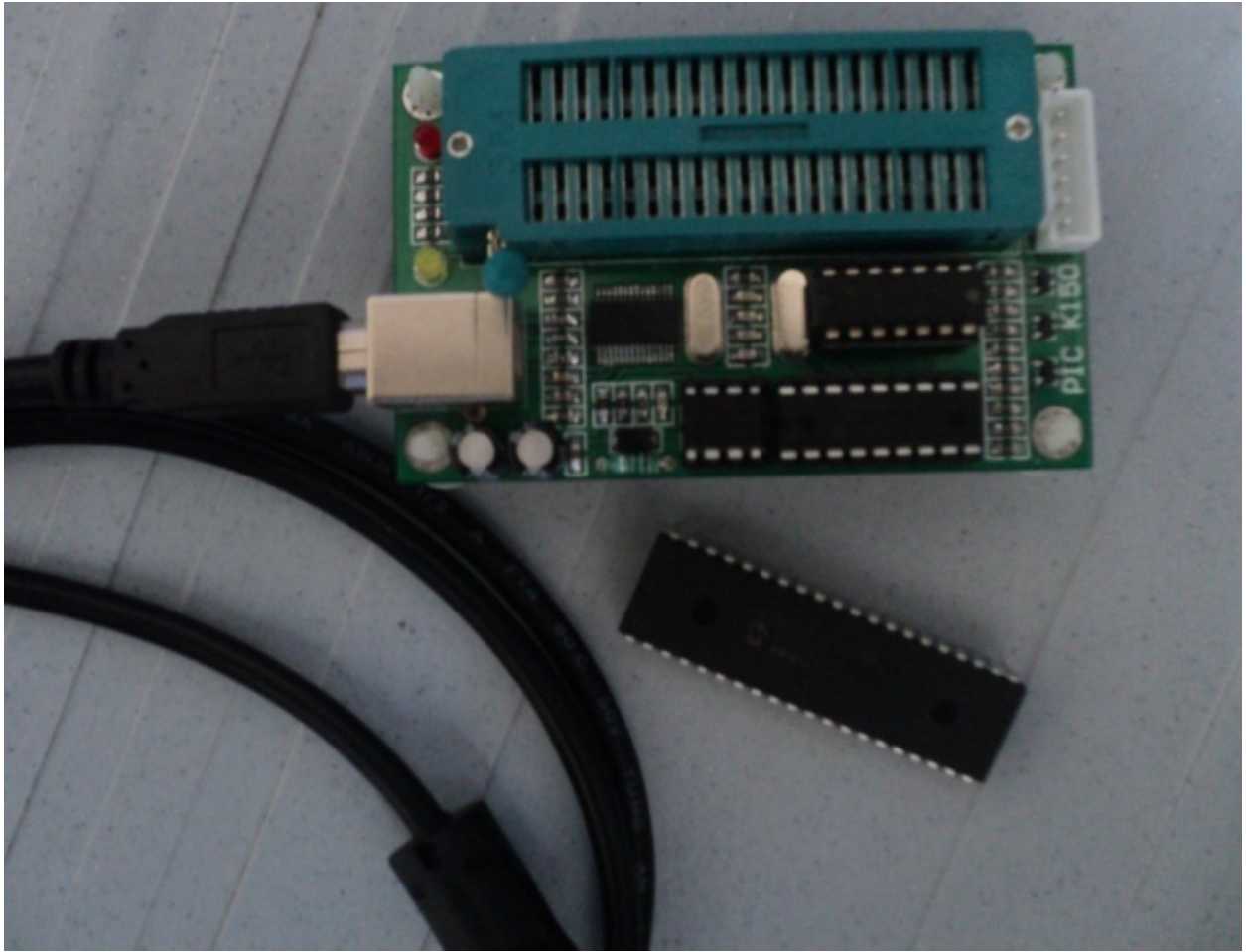

Fig.(3-67) Kit K150

### 3.8.2 Touch Screen Program :

The touch screen from DELTA can be program in special software " screen editor " and design the logo of screen's on the same software .First step in program connect all commend in internal plc relay "Flag's" (M0-M999) And some command will be need some register in PLC and (D0-D999).The first screen in touch screen show in the Fig.(3-68) :



Fig.(3-68) Touch Screen

In the following small example describe some commends in Fig.(3-69):

Reversing induction motor can be select from manual from Touch screen and Hand winch switch "COB" upon the value of analog input from load cell .

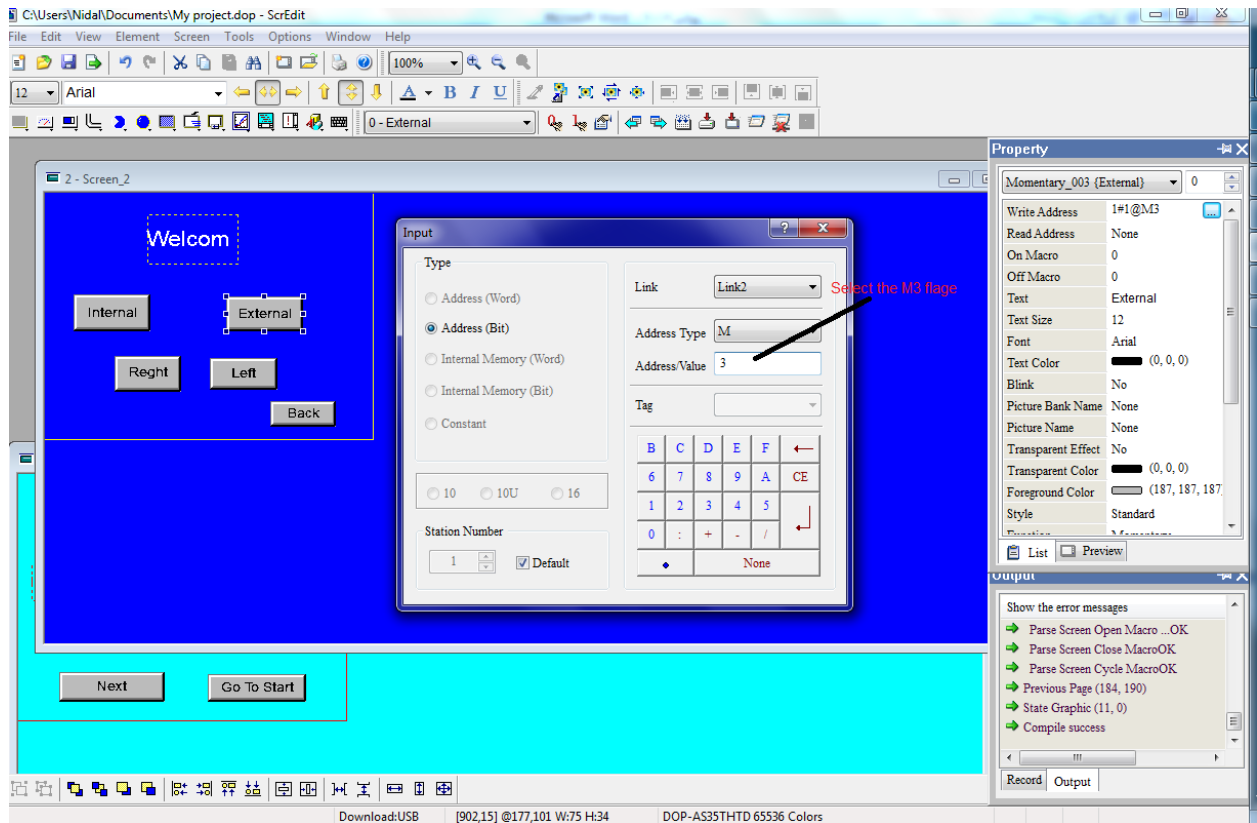

Fig.(3-69) example of Reversing induction motor

Selecting flag M3 to External Hand winch action ,show Fig.(3-70)

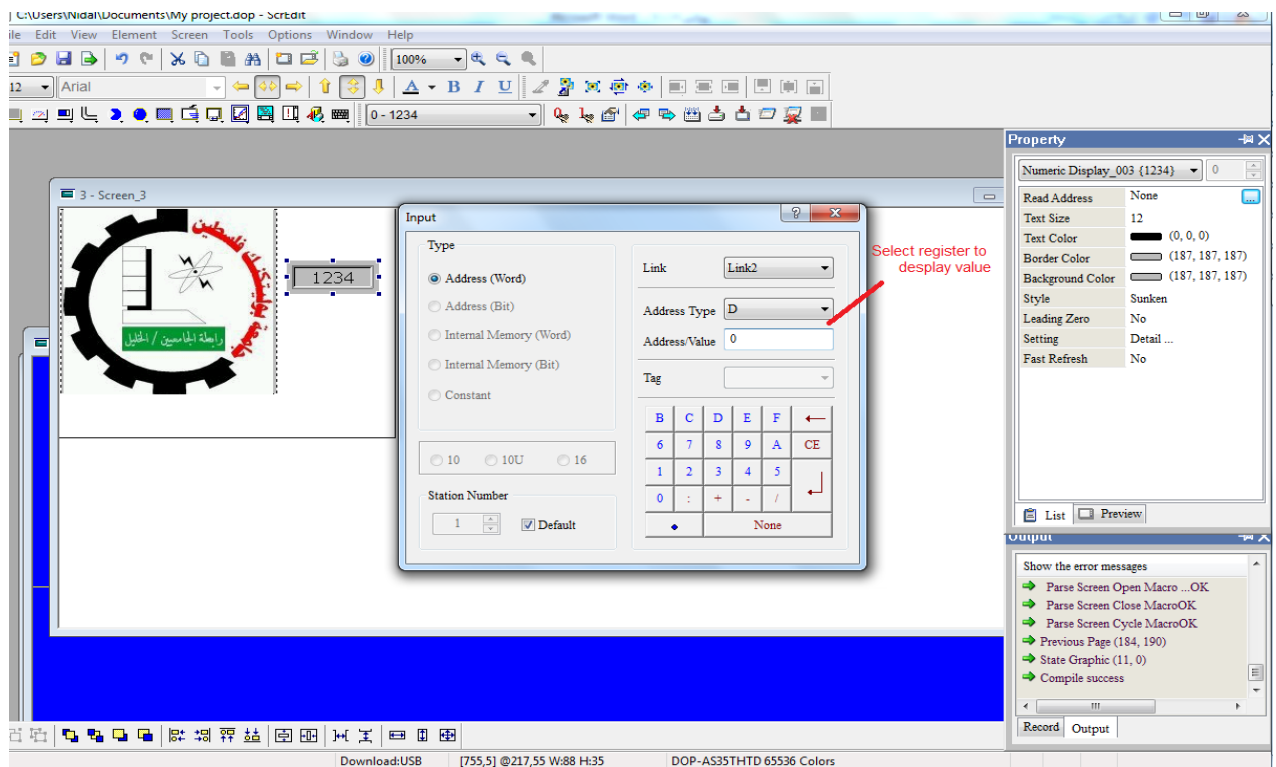

Fig.(3-70) touch screen programming

Now Insert the PPU Logo and Display the register D0 value.

**3.8.3 PLC Program :**

The Delta PLC software called " WPLSoft"  
The following program consist from analog input and analog output and connect in touch screen , show Fig.(3-71) :

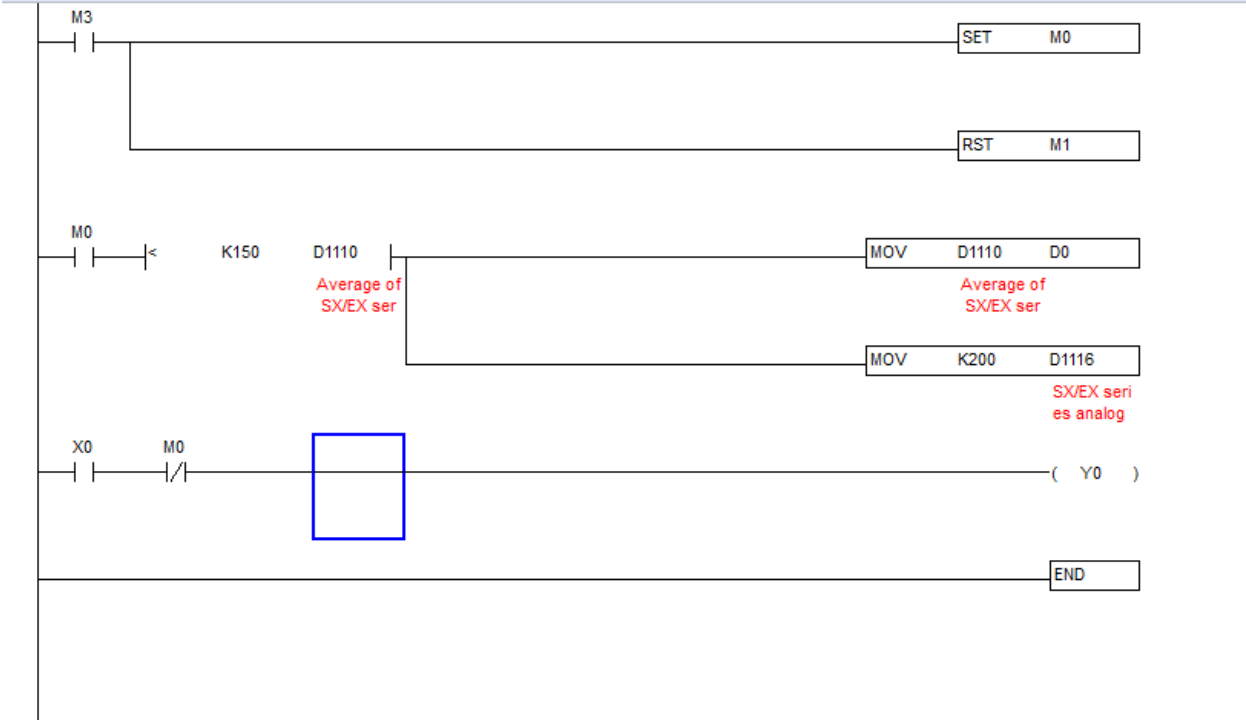

Fig.(3-71) PLC program

### 3.9- Safety and Protection :

Design any electrical or mechanical device must include on the side of safety for humans and the protection of the device .Cost is the third step in the design process and comes after the first class in safety and protection in second class and since of this most valuable human life in the cosmos may not be reduced to reduce the cost and safety, and also for the protection of the device, Fig.(3-72) descirp the priority at design any System spicily electrical system .

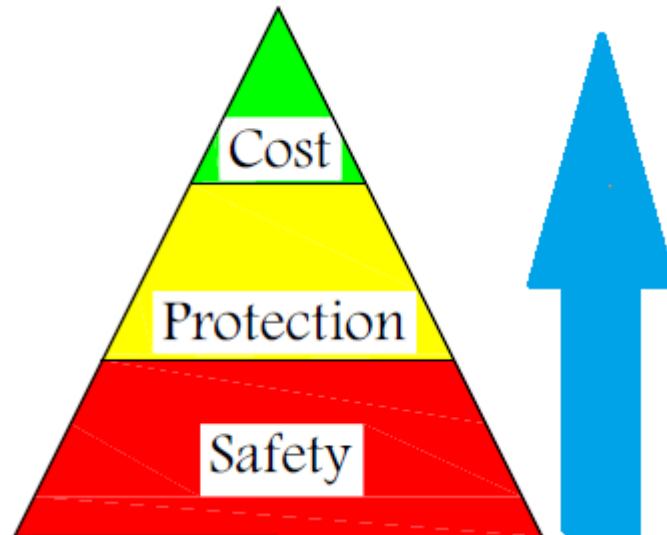

Fig.(3-72) priority triangle

Lower Limb Rehabilitation System include many of safety and protection equipment, for example the barrier install in the both side of the treadmill to provide the safety of trainee and covered with sponge , the position sensor install in the Lokolift roof to stop the motor winch at the distance between it and trainer head .

The project has several things to provide safety to the patient and protection the device; Because any fault in the device or problem occurs for the patient that leads to complications for the patient , Therefore, we must provide complete saftey for the patient and the project standards of safety are as follows :

- 1- When occur excessive increase of the patient heart rate that causes alarm from device ,this indicator on patient fatigue as a result running on a treadmill.
- 2- When the patient fall to forward ,this produce voltage in accelerometer in (z-axis),then PLC give an command to winch to lift the patient when his weight on tread mill become zero.
- 3- When the patient head approach near from the top of device (where the position sensor fixed) this cause command from PLC to stop the Lifting winch.
- 4- In case of occur any fault there is button called (emergency switch),when is pressed the system stop completely.
- 5- the barrier install in the both side of the treadmill to provide the safety of patient.

## Summary :

Lower Limb Rehabilitation System is full automatic system can be support the stroke and spinal cord injury patient to restore the walking ability and stimulate the brain cells after damage and provide all safety measuring to patient and physiotherapist along the treatment state.

This automatic system used the PLC technology to provide full automatic controller via some sensors to income the state of electrical and mechanical component , some sensors can be help to know the patient state , for example the tension sensor measuring the human body weight .

Touch Screen is high technology method to display some values and allow to full calibration for the system and easy to use it , and decreasing the number of manual switches.

To improve the treatment state included some biomedical devices in system work. EMG device can be support the physiotherapist to know the patient muscles activity and in the same time control of EMS device to stimulate the inactive muscles. Patient Heartbeat also provide part of safety to patient and help to diagnostic the patient state.

# CHAPTER "4"

## SUMMARY

---

4.1 Marketing

4.2 Conclusion

4.3 Recommendations

## **4.1 – Marketing**

lower limb rehabilitation system is a participatory system between the engineering and medical , aims to promote and develop the medical side in general specially the physical therapy side.Lower Limb Rehabilitation System find to help to improve the level of physiotherapy and health care in Palestine from new and easy to use technology .This system can be easily transferred from one place to another are also easily installed and assembled, and compared with few cost and high-performance work .

## **4.2 – Conclusion**

At the end of Theoretical design of the system can come up with some preliminary conclusions before reaching the stage of practical Implementation, in the following some of the conclusions:

- 1) Design system able to save time and cost in rehabilitation part .
- 2) Design system able to improve the level of physiotherapy, Especially at the level of Palestine.
- 3) Design system able to provide the safety and protection to patient and physiotherapist.
- 4) Design system able to help the physiotherapist.
- 5) Use high technology to design new rehabilitation system.
- 6) Use high technology in the hospital and rehabilitation center.
- 7) Development engineering and medical in Palestine.

## **4.3 – Recommendation**

At the end of this work can come up with some recommendations for the local community and global :

- 1) Design of robotic system " Lokomat", which helps the patient to move the lower limbs.
- 2) Design EEG and ECG system to help the doctor or physiotherapist to monitor the status of the patient.
- 3) Design additional system able to transfer the patient state to physiotherapist on hospital and receive the orders of operation and calibration from physiotherapist on hospital.
- 4) Recommendation to the government and supporting institutions to the attention of treatment and physical therapy robots automatic.
- 5) Presence uninterruptible power supply for this project ; UPS is typically used to provides emergency power to a load when the input power source, fails, unexpected power disruption.



## REFERENCES

- [1] Elias Mpofu and Thomas Oakland, *Rehabilitation and Health Assessment*, Springer Publishing Company, 2010 .
- [2] FERDI SCHEEPERS, RICHARD E. PARENT and WAYNE E. CARLSON, *Anatomy-Based Modeling of the Human Musculature* , SIGGRAPH 97 conference , 1997.
- [3] Han Jian-hai, Guo Binjing and Zhao Shu-shang, *Structure Design and Trajectory Control on Gait Rehabilitation Training Robot System Driven by Pneumatic Actuators*, Proceedings of the 2011 International Conference on Advanced Mechatronic Systems, Zhengzhou, China, August 11-13, 2011.
- [4] Ou Ma, Andres Hernandez and Jianxun Liang, *A Testbed for Testing an Active Body Support System for Locomotion Training*, Proceedings of the 2008 IEEE/ASME International Conference on Advanced Intelligent Mechatronics, China, 2008.
- [5] S. Mazzoleni, E. Boldrini and C. Laschi, M. C. Carrozza, *Brain Activity Changes Associated With Treadmill Training After Stroke* , Stroke is published by the American Heart Association. 7272 Greenville Avenue, Dallas, TX 72514, Copyright © 2009 American Heart Association.
- [6] Michael John McNulty and Pdraig Fogarty, *Heart Disease and Stroke Statistics 2011 Update* : A Report From the American Heart Association, Circulation 2011, 123:e18-e209: originally published online December 15, 2010 .
- [7] Bruce Carter and Thomas R. Brown, *A Novel Mechatronic Body Weight Support System*, *IEEE TRANSACTIONS ON NEURAL SYSTEMS AND REHABILITATION ENGINEERING*, VOL. 14, NO. 3, SEPTEMBER 2006 .
- [8] S. Mazzoleni, E. Boldrini and C. Laschi, M. C. Carrozza, *Changes on EMG activation in healthy subjects and incomplete SCI patients following a robot-assisted locomotor training*, 2011 IEEE International Conference on Rehabilitation Robotics Rehab Week Zurich, ETH Zurich Science City, Switzerland, June 29 - July 1, 2011.
- [9] Suzanne Helliwell MSc - Neuro-Physiotherapist, *STROKE REHABILITATION*, Watford General Hospital. UK,1998.
- [10] A.J.H. Mohideen and S.N. Sidek, *Development of EMG Circuit to Study the Relationship between Flexor Digitorum Superficialis Muscle Activity and Hand Grip Strength*, 2011 4th International Conference on Mechatronics (ICOM), Kuala Lumpur, Malaysia , 2011

[11] Martin Frey, Gery Colombo, Martino Vaglio, Rainer Bucher, Matthias Jörg, and Robert Riener, *A Novel Mechatronic Body Weight Support System*, IEEE TRANSACTIONS ON NEURAL SYSTEMS AND REHABILITATION ENGINEERING, Roma, 2006.

[12] A.J.H. Mohideen and S.N. Sidek, *Development of EMG Circuit to Study the Relationship between Flexor Digitorum Superficialis Muscle Activity and Hand Grip Strength*, 2011 4th International Conference on Mechatronics (ICOM), Kuala Lumpur, Malaysia , 2011.

[13] Michael John McNulty and Padraig Fogarty, *Design of a Highly Efficient Circuit for Electrical Muscle Stimulation*, European Regional Development Fund (ERDF), University of Limerick , Ireland,2006.

[14] Mohamed A. El-Sharkawi, *Fundamental of Electric Drives*, Cengage Learning, Canada, 2008.

[15] Dr.P.C.Sharma and Dr.D.K.Aggarwal, *Machine Design (SI Units)*,Publishers of Engineering and Computer Books, Ansari Road – Darya Ganj – New Delhi – 110002 , Eleventh Edition 2006-07 .

[16] Ou Ma, Xiumin Diao, Lucas Martinez, and Thompson Sarkodie-Gyan, *Dynamically Removing Partial Body Mass Using Acceleration Feedback for Neural Training*, Proceedings of the 2007 IEEE 10th International Conference on Rehabilitation Robotics, Noordwijk, 2007.

[17] Qi Lu, Jianxun Liang, Bing Qiao, and Ou Ma, *A New Active Body Weight Support System Capable of Virtually Offloading Partial Body Mass*, IEEE/ASME TRANSACTIONS ON MECHATRONICS (2011),p.p. 1-3 .

[18] Roy Beardmore, *Timing Belts*, Available at [http://www.roymech.co.uk/Useful\\_Tables/Drive/Timing\\_belts.html](http://www.roymech.co.uk/Useful_Tables/Drive/Timing_belts.html) . Last Updated\_30/04/2010

[19] Joney.Mcros , *Conveyor HandBook*, Feener Dunlop , Australia, 2009 .

[20] *Spinal cord injury: Hope through research*, National Institute of Neurological Disorders and Stroke. Available at [http://www.ninds.nih.gov/disorders/sci/detail\\_sci.htm](http://www.ninds.nih.gov/disorders/sci/detail_sci.htm). June 28, 2011.

[21] Susan J. Harkema, *Electrodes*, Available at <http://www.equinew.com/electrodes.htm> .

[22] Karlo. S, *The choice of drum*, LEBUS International, Germany, 2005.

[23] Véronique L. Roger, Alan S. Go, Donald M. Lloyd-Jones, Robert J. Adams, Jarett D. Berry, Todd M. Brown, Mercedes R. Carnethon, Shifan Dai, *Heart Disease and Stroke Statistics*, American Heart Association, 2011, p.p. 82-100.

[24] Theodore Wildi, *Electrical Machines, Drives, and Power Systems*, Sperika Enterprises Pearson Education, New Jersey, 2006.

[25] Yoshiyuki SHIBATA, Shingo IMAI, Tatsuya NOBUTOMO, Tasuku MIYOSHI and Shin-ichiroh YAMAMOTO, *Development of Body Weight Support Gait Training System using Antagonistic Bi-articular Muscle Model*, 32nd Annual International Conference of the IEEE EMBS Buenos Aires, Argentina, 2010.

[26] Zhiguo Feng, Jinwu Qian, Yanan Zhang, Linyong Shen, Zhen Zhang and Qiyuan Wang, *Dynamic Walking Planning for Gait Rehabilitation robot*, BA, Shanghai University, 2008.

[27] Lawrence K. and Jay P. Shapiro, *Cranes and Derricks*, Me Graw Hill, New York, 2000.

[28] John Hewes, *555 and 556 timer circuits*, The Electronics Club, 2011.

[29] Peter A. Stark, *High – Pass and Low – Pass filters*, Sperika Enterprises Pearson Education, 2004.

[30] John Hewes, *555 and 556 timer circuits*, The Electronics Club, 2011.

[31] Michael John McNulty and Padraig Fogarty, *Design of a Highly Efficient Circuit for Electrical Muscle Stimulation*, European Regional Development Fund (ERDF), University of Limerick, Ireland, 2006

[32] Bruce Carter and Thomas R. Brown, *Handbook Of Operational Amplifier Applications*, Texas Instruments, October 2001.

[33] Gert Jan Gelderblom, Monique De Wilt, Ger Cremers and Arjan Rensma, *Rehabilitation Robotics in Robotics for Healthcare*, A Roadmap Study for the European Commission, 2009 IEEE 11th International Conference on Rehabilitation Robotics Kyoto International Conference Center, Japan, 2009

[34] Mathias Wellner, Marco Guidali, Joachim von Zitzewitz and Robert Riener, *Using a Robotic Gait Orthosis as Haptic Display - A Perception-Based Optimization Approach*, Proceedings of the 2007 IEEE 10th International Conference on Rehabilitation Robotics, Noordwijk, 2007.

- [35] I-Ju Ho, Yi-You Hou, Chich-Haung Yang , Wen-Lan Wu, Sheng-Kai Chen<sup>1</sup> and Lan-Yuen Guo, *Comparison of plantar pressure distribution between different speed and incline during treadmill jogging*, Journal of Sports Science and Medicine (2010), p.p. 1- 4.
- [36] *Using a Robotic Gait Orthosis as Haptic Display - A Perception-Based Optimization Approach*, Proceedings of the 2007 IEEE 10th International Conference on Rehabilitation Robotics, June 12-15, Noordwijk, The Netherlands
- [37] *Dynamically Removing Partial Body Mass Using Acceleration Feedback for Neural Training*, Proceedings of the 2007 IEEE 10th International Conference on Rehabilitation Robotics, June 12-15, Noordwijk, The Netherlands
- [38] *Rehabilitation Robotics in Robotics for Healthcare; A Roadmap Study for the European Commission*, 2009 IEEE 11th International Conference on Rehabilitation Robotics Kyoto International Conference Center, Japan, June 23-26, 2009
- [39] *Changes on EMG activation in healthy subjects and incomplete SCI patients following a robot-assisted locomotor training*, 2011 IEEE International Conference on Rehabilitation Robotics Rehab Week Zurich, ETH Zurich Science City, Switzerland, June 29 - July 1, 2011.
- [40] *EMG Signal Analysis for Identifying Walking Patterns of Normal Healthy Individuals* , Indian Journal of Biomechanics (7-8 March 2009)
- [41] *A New Active Body Weight Support System Capable of Virtually Offloading Partial Body Mass*, IEEE/ASME TRANSACTIONS ON MECHATRONICS @2011 .

