

بِسْمِ اللَّهِ الرَّحْمَنِ الرَّحِيمِ

**Palestine Polytechnic University
College of Engineering**



Vertical wall printer

By

Ibrahim Samir Al-naimi

Ashraf Jamal Al-adam

Supervisor: Eng. Ayman wazwaz

Submitted to the College of Engineering
in partial fulfillment of the requirements for the
Bachelor degree in Mechatronics Engineering

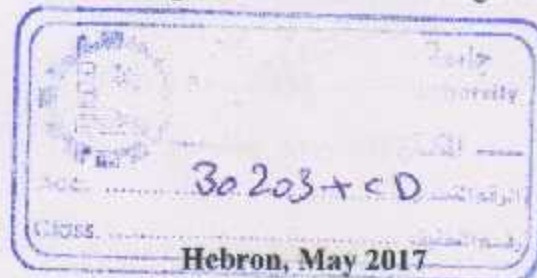



Palestine Polytechnic University

College of Engineering

Department of mechanical Engineering

Hebron - Palestine

By

Ashraf Jamal Aladam

Ibrahim Samir Issa Alnaimi

Submitted to the College of Engineering
in partial fulfillment of the requirements for the
Bachelor degree in Mechatronics Engineering

Supervisor Signature

Testing Committee Signature

Chair of the Department Signature

Hebron, May 2017

Abstract

This project aims to design a system to print on walls. This project will make the drawing on the vertical wall more easy and available for common people. The cost of drawing on the walls will become lower than the previous because we do not need a designer to complete the painting on the wall. And this project provides a higher precision than hand drawing on the walls. Also we can achieve the paint faster than hand drawing.

المخلص

هذا المشروع يهدف الى تصميم و تصنيع طباعة جدارية , بحيث تصبح الطباعة على الجدران من خلال هذه الطباعة سهلة و متاحة للجميع دون الحاجة الى وجود مهندس ديكور أو رسام للرسم على الجدران. الرسم اليدوي على الجدران يعتبر طريقة مكلفة و تستهلك الكثير من الوقت و الجهد للوصول إلى الأداء المطلوب في رسم اللوحة الجدارية. بينما الرسم من خلال الطباعة الجدارية أكثر من جودى من حيث تقليل الوقت و التكلفة اللازمين. و أيضاً تمنحنا دقة عالية في الأداء.

contents

Abstract.....	III
Abstract.....	III
Contents.....	III
List of figure.....	III
List of table.....	III
Chapter1: introduction	
1.1 overview.....	2
1.2 Recognition of the need.....	2
1.3 Project importance.....	2
1.4 Requirements.....	3
1.4.1 Hardware requirements	3
1.4.2 Software requirements.....	3
1.5 approach.....	3
1.6 Related work.....	4
1.6.1 Drawing CNC (Computer Numerical Control) machine	4
1.6.2 3_D printing.....	4
1.6.3 Wood carving CNC machine.....	5
1.6.4 Printed Circuit Board Prototyping Machine.....	5
1.7 Budget.....	6

1.8 Schedule.....	7
-------------------	---

Chapter 2: Principle concepts

2.1 introduction.....	10
2.2 printer head.....	10
2.2.1 Type of printer head	10
2.2.2 Color system	13
2.2.3 Epson I355.....	14
2.2.3.1 Design	15
2.2.3.2 Processor and Memory	15
2.2.3.3 Print Performance	16
2.2.3.4 Connectivity.....	16
2.2.3.5 Ink compatibility.....	16
2.2.3.6 The Components that will be extracted from Epson I355.....	16
2.3 Stepper motors and drivers.....	16
2.3.1 Stepper motor	17
2.3.2 Driver of stepper motor	19
2.4 Microcontroller	21
2.4.1 Specification of arduino mega.....	21

Chapter three: Structural design

3.1 introductions.....	23
3.2 Design the frame.....	23
3.2.1 Beams.....	24
3.2.2 Linear Motion shaft.....	24
3.2.3 Linear Motion slide.....	24

3.2.4 Flanged block supporter.....	25
3.2.5 Stepper motor bracket.....	26
3.2.6 Vertical frame.....	26
3.2.6.1 Lead screw.....	27
3.2.6.2 Screw nut.....	27
3.2.6.3 Stepper motor coupler.....	28
3.2.6.4 Mounted ball bearing.....	28
3.2.7 X-axis frame.....	29
3.2.7.1 Timing pulley.....	29
3.2.7.2 Open end timing belt.....	29
3.3 connections between components.....	31
3.3.1 Connection between computer and printer head.....	31
3.3.2 Connection between microcontroller and printer head.....	32
3.4 Flowchart and block diagram.....	32
3.4.1 Block diagram.....	32
3.4.2 Flowchart.....	33
3.4.3 How it works.....	35
3.5 drawings for the project.....	36

Chapter four: Calculation and analysis

4.1 Introduction	39
4.2 Dynamic analysis.....	39
4.2.1 The motion in Y axis	39
4.2.1.1 Power screw mechanism.....	39
4.2.1.2 Calculating required torque	41
4.2.2 The motion in X axis	46

Chapter five: Manufacturing and assembly

5.1 Introduction.....	48
5.2 Disassembly the printer.....	48
5.2.1 Remove the scanner unite.....	48
5.2.2 Removing the cover of the printer.....	50
5.2.3 Extraction the printer head	50
5.3 assembly of wall printer.....	51
5.3.1 Linear bearing motion installation.....	51
5.3.2 Linear guide motion and Y-axis installation.....	52
5.3.2.1 The frame of Y-axis.....	53
5.3.2.2 Flanged Block supporter installation	53
5.3.3 Y-axis stepper motor installation.....	54

5.3.4 Lead screw installation	55
5.3.4.1 Coupler installation	55
5.3.4.2 Mounted ball bearing installation	55
5.3.4.3 Screw nut installation	56
5.3.5 Installation the frame of X-axis	57
5.3.5.1 Linear bearing motion installation.....	57
5.3.5.2 Linear guide motion installation	58
5.3.6 X-axis stepper motor installation	59
5.3.7 Timing pulley installation.....	59
5.3.8 Open end timing belt.....	60
5.3.9 Optical limit switch installation.....	60
5.3.10 vacuum holder installation.....	61

Chapter six : Testing and Calibration

6.1 Testing the printer	62
6.2 Testing the printer head	62
6.2.1 Printing one colored line	62
6.2.2 Solving the problem of printing a colored line	63
6.2.3 Printing an one colored A4 image.....	63
6.2.4 Printing two vertical colored A4 image	65
6.2.5 Printing two horizontal colored A4 image	68
6.3 Process the image by C#	68

List of Figure

Figure NO.	Name of figure	page
Figure 1.1	X,Y plotter	4
Figure 1.2	3_d printer	5
Figure 1.3	Wood craving CNC machine	5
Figure 1.4	Printing circuit board prototyping machine	6
Figure 2.1	Laser printer	10
Figure 2.2	Inkjet printer	11
Figure 2.3	Thermal printer head	12
Figure 2.4	Piezo electric technology	13
Figure 2.5	RGB system	13
Figure 2.6	CMYK system	14
Figure 2.7	Epson L355	15
Figure 2.8	Stepper motor	17
Figure 2.9	Open loop controller	18
Figure 2.10	Stepper motor driver	19
Figure 2.11	Connection between driver and stepper motor	20
Figure 2.12	Arduino mega	21
Figure 3.1	Main frame	23
Figure 3.2	Beams	24
Figure 3.3	Linear shaft motion	24
Figure 3.4	Linear motion slide	25
Figure 3.5	Flanged block supporter	25
Figure 3.6	Stepper motor bracket	26
Figure 3.7	Vertical frame	26
Figure 3.8	Lead screw	27
Figure 3.9	Screw nut	27
Figure 3.10	Stepper motor coupler	28
Figure 3.11	Mounted ball bearing	28
Figure 3.12	Timing bully	29
Figure 3.13	Open end timing belt	30
Figure 3.14	Design	30
Figure 3.15	Wi-Fi connection	31
Figure 3.16	Block diagram	33

Figure NO.	Name of figure	page
Figure 3.17	Flow chart	34
Figure 3.18	Frame layout	36
Figure 3.19	Printer head	36
Figure 3.20	Mechanism of motion	37
Figure 4.1	Power screw	40
Figure 4.2	Trapezoidal screw	40
Figure 4.3	The lead angle	42
Figure 5.1	Removing the scanner unite	51
Figure 5.2	After Removing the scanner unite	51
Figure 5.3	Removing the cover	52
Figure 5.4	Extraction the printer head	52
Figure 5.5	Connect the bearing with printer head	53
Figure 5.6	Linear guide motion and Y-axis installation	54
Figure 5.7	Flanged of supporter installation	55
Figure 5.8	Y-axis stepper motor installation	56
Figure 5.9	Stepper motor coupler installation	57
Figure 5.10	Mounted ball bearing installation	58
Figure 5.11	Screw nut installation	58
Figure 5.12	Installation the frame of X-axis	59
Figure 5.13	Linear bearing motion installation	60
Figure 5.14	Linear guide motion installation	60
Figure 5.15	X-axis stepper motor installation	61
Figure 5.16	Timing pulley installation	61
Figure 5.17	Open end timing belt	62
Figure 5.18	Vacuum holder installation	63
Figure 6.1	First testing of colored line	66
Figure 6.2	Printing colored A4 image	67
Figure 6.3	First colored A4 image	68
Figure 6.4	Vertical distance between two image	69
Figure 6.5	Print two image as one unit	70
Figure 6.6	Printing two horizontal image	71
Figure 5.7	Interface window	72
Figure 6.8	Upload image	72
Figure 5.9	Save 6 sections	73

List of tables

Table No.	Name of table	Page
Table 1.1	Cost of components	6
Table 1.2	Tasks description	7
Table 1.3	First semester time table	8
Table 1.4	second semester time table	8

CHAPTER ONE

INTRODUCTION

1.1 Overview

1.2 Recognition of the need

1.3 Project importance

1.4 Requirements

1.4.1 Hardware requirements

1.4.2 Software requirements

1.5 approaches

1.6 Related work

1.6.1 Drawing CNC (Computer Numerical Control) machine

1.6.2 3D printing:

1.6.3 Wood carving CNC machine

1.6.4 Printed Circuit Board Prototyping Machine:

1.7 Budget

1.8 Schedule

1.1 Overview:

In this chapter, a brief description of the system will be shown, starting with objectives, importance of vertical wall painter technology, hardware and software requirements, finally the project approach.

1.2 recognition of the need:

- 1) Print a panel directly on the walls automatically.
- 2) The project will achieve a final picture with suitable precision on the walls.
- 3) The cost of printing on walls by the wall printer will be cheaper and faster than the traditional ways.
- 4) The painting on the wall will be easy.

1.3 Project importance:

The importance of vertical wall printer contains the following features and characteristics:

- 1) This project aims to design a system to print on walls with different scales.
- 2) This project will make the drawing on the vertical wall more easy and available for common people.
- 3) The cost of drawing on the walls will become lower than the previous because we do not need a designer to complete the painting on the wall.
- 4) This project provides a higher precision than hand drawing on the walls.
- 5) We can achieve the paint faster than hand drawing.

1.4 Requirements:

This system requires hardware and software requirements in order to make vertical wall painter

1.4.1 Hardware requirements:

- 1) Microcontrollers.
- 2) Stepper motors.
- 3) Printer head.
- 4) X,Y coordinate frame.

1.4.2 Software requirements:

Programming language

- 1) C++: use in the microcontroller to control the operation of motion for the printer head and the operation of starting and ending the printing.
- 2) C#(C sharp): it will program in the computer to input the image by user and process it and prepare it for printing.

1.5 Approach:

The project consists of two main parts:

- 1) Hardware: it contains an X, Y coordinate frame, and the head of the printing move by stepper motors in the two coordinates.
- 2) Software: we will write a code in microcontroller to control the position of stepper motors to move the head of the painter in the two coordinate.

And the project will work as explained in the following steps:

- 1) Input the required photo into the computer.
- 2) The computer will process the photo and split it to the parts
- 3) The computer sends the command to the head printer to start printing.
- 4) The microcontroller control the stepper motors to move the head printer in right path.
- 5) We will get the input photo as a photo on the vertical wall.

1.6 Related work:

1.6.1 Drawing CNC (Computer Numerical Control) machine

This project convert the photo to a G-code and this code give an X, Y coordinate. Then the CNC machine follows this coordinate by using stepper motors to achieve the final photo on a paper by a simple pen[1].

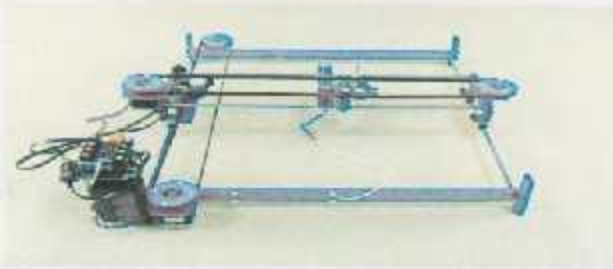

Figure 1.1: X, Yplotter [1]

1.6.2 3D printing:

3D printing or additive manufacturing is a process of making three dimensional solid objects from a digital file.

In an additive process an object is created by laying down successive layers of material until the object is created.

Each of these layers can be seen as a thinly sliced horizontal cross-section of the eventual object[2].



Figure 1.2:3D_printer

1.6.3 Wood carving CNC machine

It is a 3D carving on a wood surface by converts the required photo to a three coordinate and then drilling the wood by follow this coordinate to get the photo[3].



Figure 1.3: Woodcarving CNC machine

1.6.4 Printed Circuit Board Prototyping Machine:

The project implements a portable printed circuit board machine which is capable of producing PCB based on an input layout file from CAD/CAM application. The project goes through set of sequential processes. The milling process aims to make electrical insulation about the signal traces. The drilling process through the board aims to make places to allow insertion of leaded semiconductor components.



Figure 1.4: Printed Circuit Board Prototyping Machine

1.7 Budget:

The Table 1.1 describes the cost for main components in our project and the number of each component.

Table 1.1: costs of components

Part name	#of part	Cost of each part	Total(JD)
Printer head	1	100	100
Stepper motor	2	50	100
Frame layout	1	400	400
Electronic elements		50	5
Arduino	1	20	20

1.8 Schedule:

Table 1.2: Tasks description

	Task description
T1	Selection of idea
T2	Collecting the Data
T3	Collecting References from libraries
T4	Collecting References from websites
T5	Select a initial design
T6	Create and draw the selected design
T7	Selection of Components
T8	Select the mechanical parts
T9	Documentation
T10	Prepare the 1 st presentation
T11	order of the components
T12	Buy the mechanical and electronic parts
T13	Do some variations if required
T14	Build the project
T15	Put the mechanical and electronic parts of the system
T16	Write the C++ code
T17	Write the C# code
T18	Test the result
T19	Correction the errors
T20	Documentation
T21	Make a final adjustments on the text
T22	Prepare for the final presentation

Table 1.3: First semester time table

Task/Week	1	2	3	4	5	6	7	8	9	10	11	12	13	14
T1	█	█	█	█	█									
T2					█	█								
T3					█	█	█	█	█					
T4					█	█	█	█	█					
T5									█					
T6									█					
T7										█	█	█	█	
T8										█	█	█	█	
T9							█	█	█	█	█	█	█	
T10												█	█	█

Table 1.4: second semester time table

Task/Week	1	2	3	4	5	6	7	8	9	10	11	12	13	14
T11	█													
T12		█	█	█										
T13					█	█								
T14						█	█	█	█					
T15								█	█					
T16									█	█				
T17										█	█	█	█	
T18										█	█	█	█	
T19										█	█	█	█	
T20	█	█	█	█	█	█	█	█	█	█	█	█	█	
T21												█	█	
T22												█	█	█

CHAPTER TWO

PRINCIPLE CONCEPTS

2.1 Introduction

2.2 printer head

2.2.1 Type of printer head

2.2.2 Color system

2.2.3 Epson I355

2.2.3.1 Design

2.2.3.3 Print Performance

2.2.3.4 Connectivity

2.2.3.5 Ink compatibility

2.2.3.6 The Components that will be extracted from Epson I355

2.3 Stepper motors and drivers

2.3.1 Stepper motor

2.3.2 Driver of stepper motor

2.4 Microcontroller

2.4.1 Specifications

2.1 Introduction

The main objectives in this chapter are to show the main concepts in wall printer project, and describe the main components in our project, and describe the connection between them.

2.2 Printer head:

The printer head is the main component of our project because it is the responsible of jetting the ink on the walls so we have to select the appropriate printer head in our project.

2.2.1 Type of printer head:

1) Laser printer head:

Laser printer head is not suitable for our project because the wall cannot absorb the ink of this printer head, and it needs a closed environment to work well [4].

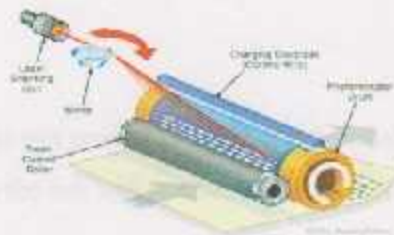

Figure 2.1: Laser printer

2) Inkjet printer head:

A type of printer that works by spraying ionized ink at a sheet of paper. Magnetized plates in the ink's path direct the ink onto the paper in the desired shapes. Ink-jet printers are capable of producing high quality print approaching that produced by laser printers. A typical ink-jet printer provides a resolution of 600 dots per inch, although some newer models offer higher resolutions [4].

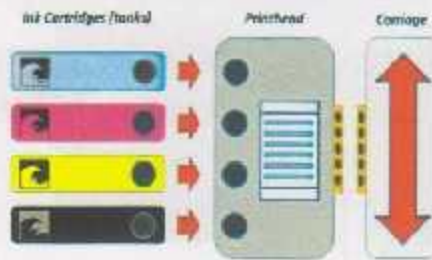

Figure 2.2: Inkjet printer head

So the inkjet printer head is more suitable to our project so we will use this type, and there is a two technology used in this type of printer head:

1) Thermal Printer head:

Thermal inkjet technology uses heat, as opposed to electricity, to force ink from the print head to the substrate. Conceptually similar to the way water bubbles when boiled, thermal inkjet technology works by electrifying microscopic resistors behind the print nozzle, creating an intense heat that vaporizes the ink to create a bubble that expands so rapidly the ink literally explodes onto the paper. After ejecting ink, the chamber then cools quickly to allow more ink to refill the chamber and the process is repeated [5].

But this technology not suitable to our project because this technology use a heat to force ink from the print head to the substrate, so the ink will not be absorbed by the wall.

Diagram 2: How a thermal inkjet print head works

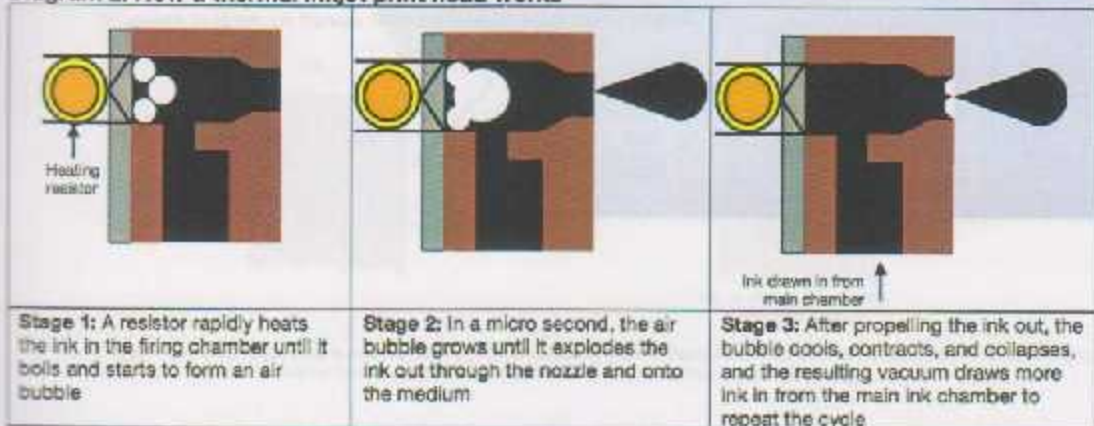
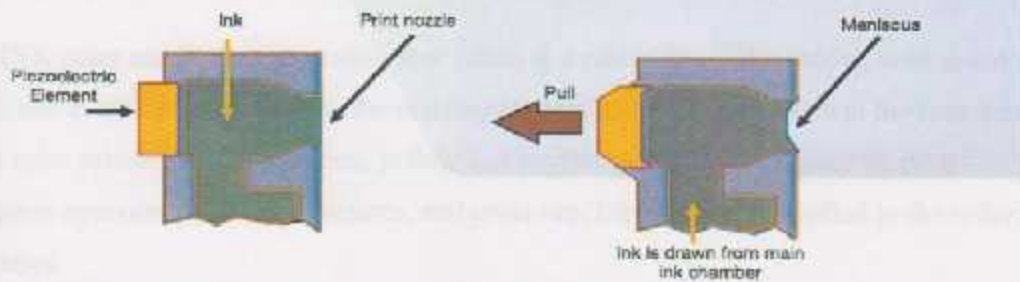

Figure 2.3: thermal printer head [5]

2) Micro Piezo printer head:

In the Epson Micro Piezo print head, microscopic piezoelectric elements (like crystals and ceramics) are built behind the print nozzles. When an electrical charge is applied to them, these elements bend backward, forcing precise amounts of ink onto the substrate. Because electrical charges can be turned on and off like a switch, there is a vast amount of control over the rate of ink being ejected through the nozzle while also creating perfectly spherical dots at different droplet sizes [5].

Diagram 1: How an Epson Micro Piezo™ print head works



Stage 1: An electrical pulse is applied to the piezoelectric element behind each nozzle. This causes the element to bend, creating a negative pressure that draws ink from the main ink chamber into the firing chamber.

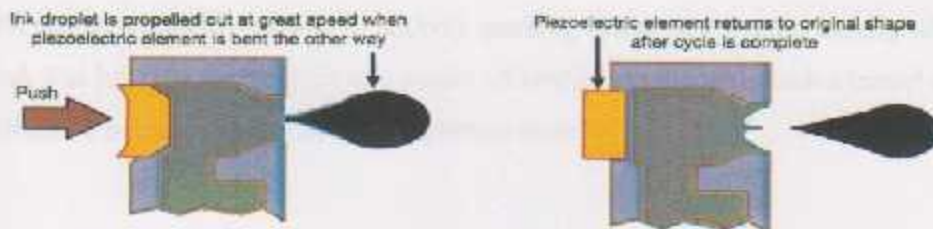

Stage 2: The electrical charge is altered, causing the piezoelectric element to rapidly push in the opposite direction, propelling the ink droplet out.

Figure 2.4: Piezo electric technology [5]

2.2.2 Color system:

There is a two type of color system used for printing:

RGB color system:

The RGB color model is an additive color model in which red, green and blue light are added together in various ways to reproduce a broad array of colors. The name of the model comes from the initials of the three additive primary colors, red, green and blue [6].



Figure 2.5: RGB system

2) CMYK color system:

The CMYK color model (process color, four color) is a subtractive color model, used in color printing, and is also used to describe the printing process itself. CMYK refers to the four inks used in some color printing: cyan, magenta, yellow and key(black). Though it varies by print house, press operator, press manufacturer, and press run, ink is typically applied in the order of the abbreviation.

The CMYK model works by partially or entirely masking colors on a lighter, usually white, background. The ink reduces the light that would otherwise be reflected. Such a model is called subtractive because inks "subtract" brightness from white.

In additive color models such as RGB, white is the "additive" combination of all primary colored lights, while black is the absence of light. In the CMYK model, it is the opposite: white is the natural color of the paper or other background, while black results from a full combination of colored inks. To save cost on ink, and to produce deeper black tones, unsaturated and dark colors are produced by using black ink instead of the combination of cyan, magenta and yellow [6].



Figure 2.6: CMYK system

2.2.3 Epson L355

Because of we cannot get an inkjet printer head to program it. So the solution of this problem is to extract a printer head from an inkjet printer. So we decided to get Epson inkjet printer (L355) shown in Figure 2.7 because it is the simplest design and combination printer. So we extract the printer head easily

The Epson L355 Multifunction Printer is a wireless printer with integrated ink system (CMYK) in or tank that is ideal for our project. And it is capable to print up to 4,000 pages in black and 6,500 pages in color.



Figure 2.7: Epson L355 [7]

2.2.3.1 Design:

Featuring Micro Piezo print head technology and Epson genuine ink, this Epson L355 Multifunction Printer can print high-quality documents of 5,760 x 1,440 DPI resolutions [7].

2.2.3.2 Processor and Memory:

This printer is compatible with a wide range of operating systems such as Mac OS 10.5.8 or later, Mac OS 10.6+, Windows 7, Windows 7 x64, Windows 8 (32/64 bit), Windows Vista, Windows Vista x64, Windows XP and Windows XP x64[7].

2.2.3.3 Print Performance:

This printer can print documents at speeds of up to 9 pages per minute in monochrome and 4.5 pages per minute in color mode. It has an output tray that can accommodate up to 30 sheets and its standard paper tray capacity is around 100 sheets [7].

2.2.3.4 Connectivity:

Epson L355 Multifunction Printer has high speed USB 2.0 connectivity that allows us to print documents from a USB device. It is also compatible for use with Wi-Fi connectivity [7].

2.2.3.5 Ink compatibility:

Unlike thermal inkjet systems, Micro Piezo systems do not use heat, which can alter the ink's material properties. Epson's Micro Piezo printer heads are thus compatible with a far wider variety of inks, including dye inks, pigment inks, eco-solvents, UV-cured ink, and a variety of other materials [7].

2.2.3.6 The Components that will be extracted from Epson L355

We need to get the printer head and its driver, the X axis motor which move the printer head on X axis and Y axis motor which transfer the paper in the printer so we have to convert this motion to vertical motion to move the printer head vertically.

And that combination must be able to print a full A4 scale on the wall. After that we will control the motion of this combination to get the full panel on the wall with required scale.

2.3 Stepper motors and drivers:

There are a two stepper motors and two drivers in our project to control the motion of printer head.

2.3.1 Stepper motor

A stepper Motor is basically a synchronous Motor. In stepper motor there is no brushes. This motor does not rotate continuously; instead it rotates in form of pluses or in discrete steps. There are different types of motors available on the basis of steps per rotation, for example- 12 steps per rotation, 24 steps per rotation etc. We can control or operate Stepper motor with the feedback or without any feedback [8].



Figure 2.8: Stepper motor [8]

The stepper motor (shown in Figure 2.8) depend an open-loop electrical circuit to provide the position at each coordinate given by the controller commands (as shown in Figure 2.9). The relatively simple circuitry involved provides great reliability, good low speed torque, and easy set-up. Positioning errors don't occur, since stepper motors know in advance where they are going and when to stop. Stepper motors are relatively inexpensive, and provide the same or greater accuracy as servo motors. Sufficiently powerful stepper motors for a given application do not lose steps. Stepper motors are no more likely to lose steps than a servo encoder is to pass bad information back to the controller.

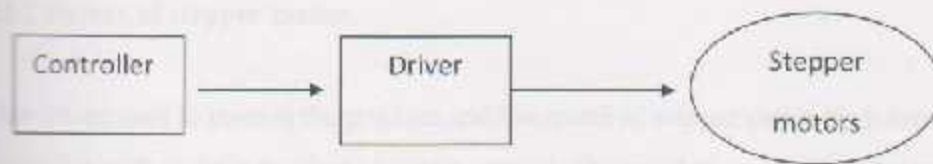

Figure 2.9: Open-loop controller

Stepper motors are DC motors that move in discrete steps. They have multiple coils that are organized in groups called "phases". By energizing each phase in sequence, the motor will rotate, one step at a time. With a controlled stepping you can achieve very precise positioning and speed control. Stepper motors move a known interval for each pulse of power. These pulses of power are provided by a stepper motor driver and are referred to as a step. As each step moves the motor a known distance it makes them handy devices for repeatable positioning. For this reason, stepper motors are the motor of choice for many precision motion CNC applications. To control the speed precisely, increments of movement allow for excellent control of rotational speed for our project processes without feedback.

Stepper motors have a step angle. A full 360° circle divided by the step angle gives the number of steps per revolution. For example, 1.8° per full step is a common step size rating, equivalent to 200 steps per revolution. Most stepper motors used for a Mendel have a step angle of 1.8 degrees. It is sometimes possible to use motors with larger step angles, however for printing to be accurate, they will need to be geared down to reduce the angle moved per step, which may lead to a slower maximum speed.

The stepper motor NEMA 23 will be used in our project to give a high torque and a good performance for controlling the motion [8].

2.3.2 Driver of stepper motor

This driver used to control the position and the speed of stepper motor by pulses sending from host controller such that the number of pulses controls the position and the frequency control the speed of the stepper motor.

The TB6560 3A was selected in our project. The TB6560 3A (shown in Figure 2.10) Working voltage (10V-35V DC) .Recommend Switching Power Supply (24V DC). 6N137 high-speed OptoCoupler , to ensure a high speed without step out New original Toshiba TB6560AHQ chip, low-voltage shutdown, of overheating parking and over-current protection circuit to ensure optimal performance. Automatic half-decay. Excitation Mode: synchronizing, half step, 1/8 step, 1/16 step, a maximum of 16 segments. [9].

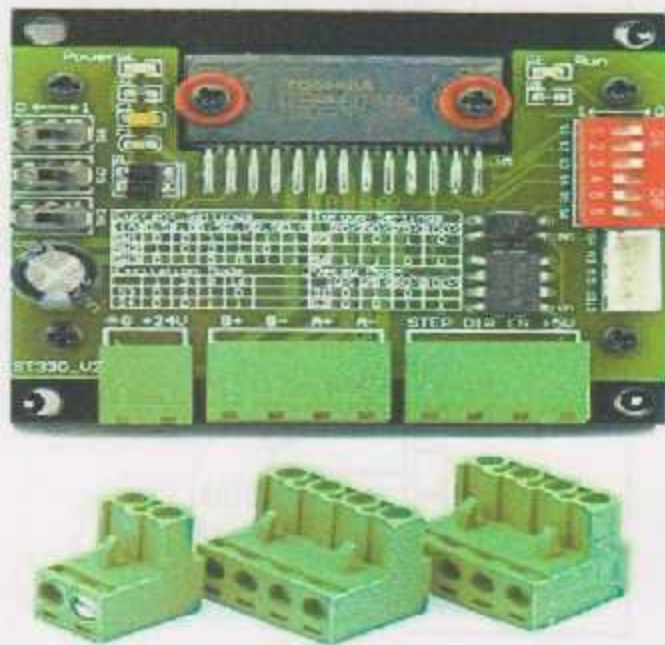

Figure 2.10: Stepper motor driver [9]

Features:

- 1) Current level by adjustable to meet your various application requirements.

- 2) Automatic semi-flow adjustable.
- 3) Using 6N137 high-speed optical coupling to ensure high speed without losing step.
- 4) Board printed setup instructions, can use without a use manual
- 5) Using thick fine-toothed radiator, good heat dissipation.

Connection between stepper motor and driver (shown in Figure 2.11)

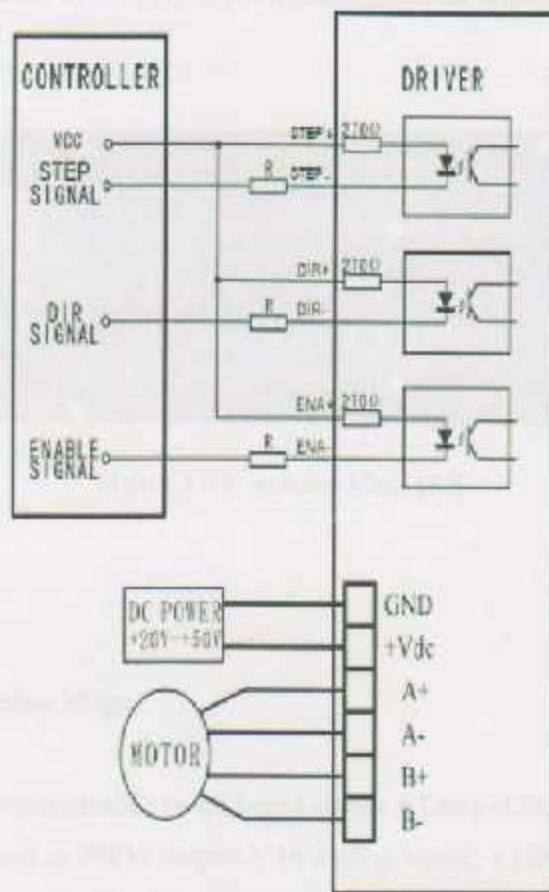

Figure 2.11: Connection between river and stepper motor [9]

2.4 Microcontroller

Microcontroller will be used to control the operation of printing:

- 1) Control the motion of printer head by stepper motors.
- 2) Control the operation of painting by control the board of printer (start and stop).

The controller that will be used in our project is Arduino Mega (as shown in Figure 2 .12)



Figure 2 .12: Arduino Mega [10]

2.4.1 Specification of Arduino Mega

The Arduino Mega is a microcontroller board based on the ATmega1280 .It has 54 digital input/output pins (of which 14 can be used as PWM outputs), 16 analog inputs, 4 UARTs (hardware serial ports), a 16 MHz crystal oscillator, a USB connection, a power jack, an ICSP header, and a reset button.

The ATmega1280 has 128 KB of flash memory for storing code (of which 4 KB is used for the bootloader), 8 KB of SRAM and 4 KB of EEPROM [10].

CHAPTER THREE

STRUCTURAL DESIGN

3.1 introductions

3.2 Design the frame

3.2.1 Beams

3.2.2 Linear Motion shaft

3.2.3 Linear Motion slide

3.2.4 Flanged Block Supporter

3.2.5 Stepper Motor Bracket

3.2.6 Vertical frame

3.2.6.1 Lead screw

3.2.6.2 Screw nut

3.2.6.3 Stepper Motor Coupler

3.2.6.4 Mounted ball bearing

3.2.7 X-axis frame

3.2.7.1 Timing pulley

3.2.7.2 Open-end timing belt

3.3 connections between components

3.3.1 Connection between computer and printer head

3.3.2 Connection between microcontroller and printer head

3.4 Flowchart and block diagram

3.4.1 Block diagram

3.4.2 Flowchart

3.4.3 How it works

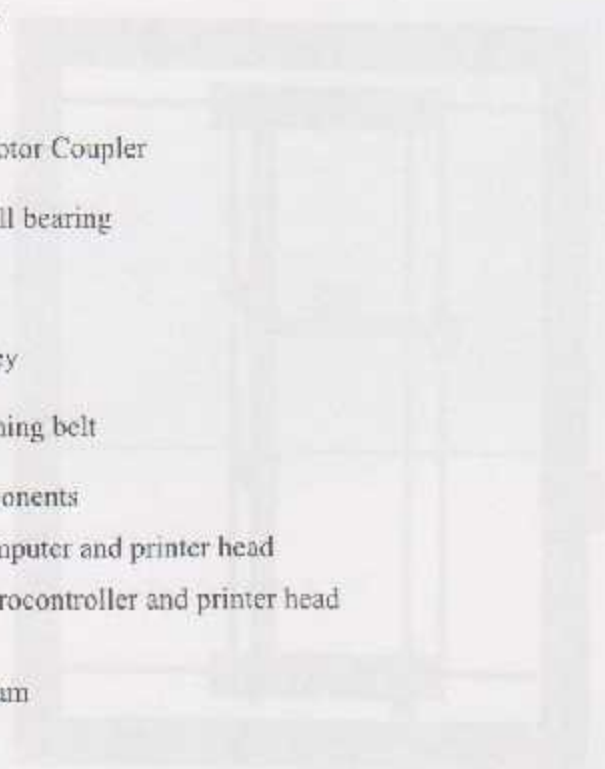

Figure 3.1: printer frame

3.1 Introductions

This chapter will discuss the Structural design of wall printer project and explain the design of the frame and its component. And describe the connection between the all components of the project, and explain the flowchart, block diagram and the procedure of our project.

3.2 Design the frame

The frame layout is an important component in wall printer project; because it holds the printer head, its driver, stepper motor and its driver so it is responsible for movement the printer head in the two coordinate X,Y in the right way, so it must be designed well to make sure the project will print the whole panel Professionally. The main frame of wall printer will be as shown in Figure 3.1.

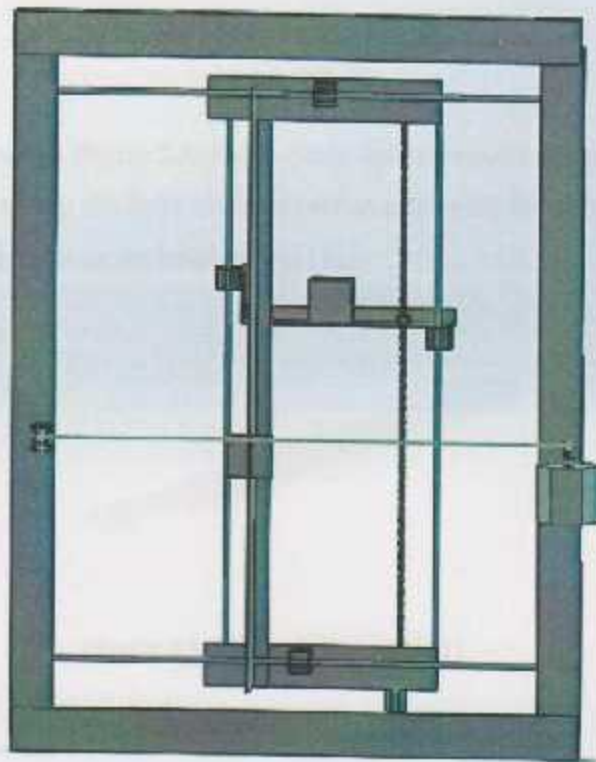

Figure 3.1: main frame

3.2.1 Beams

Beams (as shown in Figure 3.2) are used in wall printer project to fix the whole components with each other, and that important to make sure that the whole project is steady during the operation.



Figure 3.2: Beams

3.2.2 Linear Motion Shaft

The linear motion shaft shown in Figure 3.3 used to guide the movement of the printer head in the two coordinate, the linear motion shaft are made of carbon steel with finest finishing surface to have the minimum friction affects as the head moves [1].



Figure 3.3: linear shaft motion [1]

3.2.3 Linear Motion Slide

This linear motion slide shown in Figure 3.4 is a closed type slide and it use in precision linear motion applications, the slide unit, designed to carry a component, has housing with a flat mounting

face and four tapped bolt holes, and circle clips at each end to retain the ball bushing. Ball in the cage loop to run a smooth ball guide surface to ensure even if high-speed operation, low noise. And it use to connect between linear motion shaft and the moving parts in wall printer project such that the printer head.



Figure 3.4: Linear Motion Slide [1]

3.2.4 Flanged Block Supporter

Flanged Block Supporter shown in Figure 3.5 used to hold the end of the linear motion shaft, and it very important in wall printer because it works to fix the shaft to reduce the vibration of the shaft through printing, to get an excellent panel on the wall.



Figure 3.5: Flanged Block Supporter

3.2.5 Stepper Motor Bracket

Stepper motor bracket shown in Figure 3.6 use to connect the motor with the frame, to make sure the stepper motor still fixed during the operation of the wall printer.



Figure 3.6: Stepper Motor Bracket

3.2.6 Vertical frame

The vertical frame carried the printer head and its driver and ink tank, so the vertical frame hold the most of weight of our project. So the mechanism of motion of Y axis must by effective to move the small frame up and down linearly. So we used lead screw mechanism as shown in Figure 3.7.

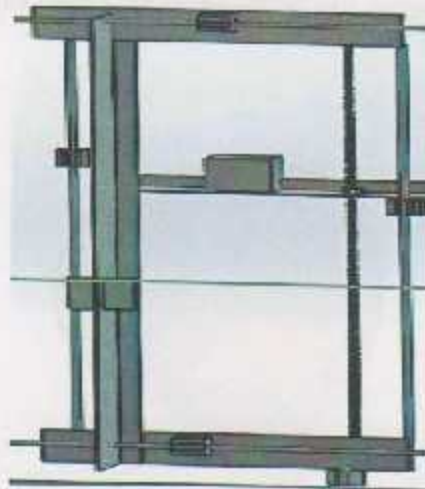

Figure 3.7: vertical frame

3.2.6.1 Lead screw

Stainless Steel Lead Screw (shown in Figure 3.8) will be used in our project to move the small frame in Y axis up and down [11].



Figure 3.8: Lead screw

3.2.6.2 Screw nut

The lead screw will connect with printer head using screw nut as shown in Figure 3.9.

And when the screw rotates by the motor the small frame will move translation up and down.



Figure 3.9: Screw nut

3.2.6.3 Stepper Motor Coupler

The motor is connected with the lead screw by motor coupler. The motor coupler is good to make sure that the motor's shaft fastens the lead screw. It is required to make sure that the coupler is tightened with the motor's shaft and the lead screw to make the tolerances as small as possible.

The coupler is designed to meet the different diameters of both; the motor's shaft diameter and the lead screw diameter.



Figure 3.10: Stepper Motor Coupler

3.2.6.4 Mounted ball bearing

The both end of the screw will hold by Mounted ball bearing (as shown in Figure 3.11) to fix the screw in the Y axis. And this bearing work to reduce the vibration during the operation of our project.



Figure 3.11: Mounted ball bearing

3.2.7 X axis frame

The belt pulley mechanism has been used to move the printer head in the X axis.

3.2.7.1 Timing Pulley

In wall printer project there is a two pulley Compared to each other (shown in Figure 3.12) in the X axis coordinate, and it used to move the printer head in X axis coordinate.



Figure 3.12: timing pulley [1]

3.2.7.2 Open-end Timing Belt

This belt (shown in Figure 3.13) used to connect the pair of pulley with moving parts like printer head, and it work to move this parts in the X coordinate along the linear motion shaft.



Figure 3.13: Open-end Timing Belt

The following figure (Figure 3.14) shows the structure design of our project.



Figure 3.14: Design

3.3 connections between components

To get a professional performance of printing on wall, the all components of the wall printer project must be synergistic integrated with each other. So this section describes the relations between all components.

3.3.1 Connection between computer and printer head:

The computer is an important part of our project because the whole processing of the image occurs in the computer, where the user input the image into the computer, then the computer process the image and split it to 12 sections in scale A4 using C# code, then the computer sends a command to printer head to print the panel on the wall. So the connection between computer and printer head, and there are a two method to connect these components:

- 1) **Wi-Fi connection:** the Epson L355 has a Wi-Fi connection feature, so we can connect the printer head with computer wireless as shown in **Figure 3.15**.
- 2) **Cable connection:** Epson L355 Multifunction Printer has high speed USB 2.0 connectivity that allows us to print from a USB device.



Figure 3.15: Wi-Fi connection

3.3.2 Connection between microcontroller and printer head

The microcontroller has to control the operation of printing, so the connection between microcontroller and printer head is very important. So the connection between these components will be As follows:

- ① The microcontroller will control the sensors of the printer to make sure the operation of printing it happened in the right way, because the printer sensors will prevent the operation of printing on the wall.
- ② The limit switch that existed on the top of the small frame will be connected with the microcontroller, where this limit switch interrupted when the printer head end printing on any section, then it will send a signal to the microcontroller

3.4 Flowchart and block diagram

This section describe the flowchart and block diagram and the procedure of the wall printer operation.

3.4.1 Block diagram

The following block diagram (shown in **Figure 3.16**) show the procedure of our project and the relations between the components.

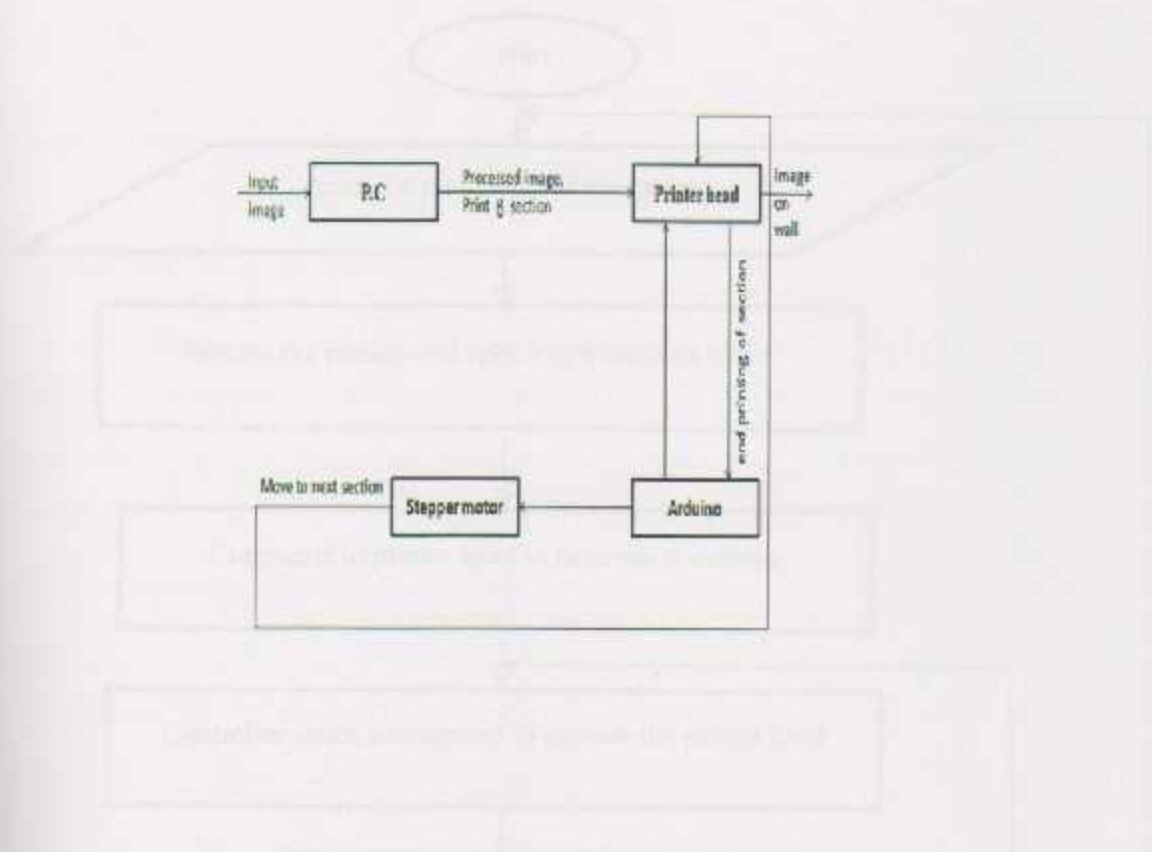
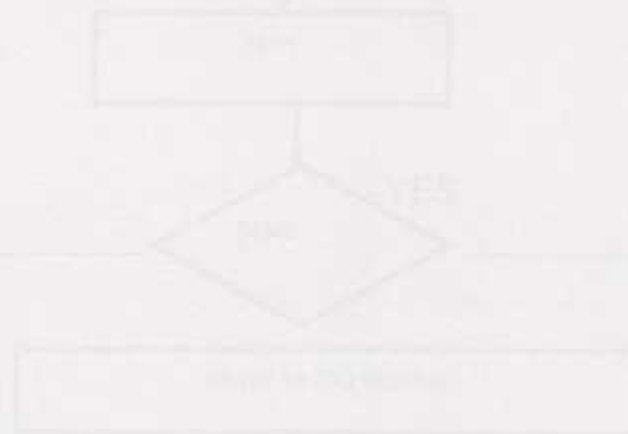

Figure 3.16: Block diagram

3.4.2 Flowchart

The following flowchart (shown in Figure 3.17) describes the sequence of the operation of the wall printer project.



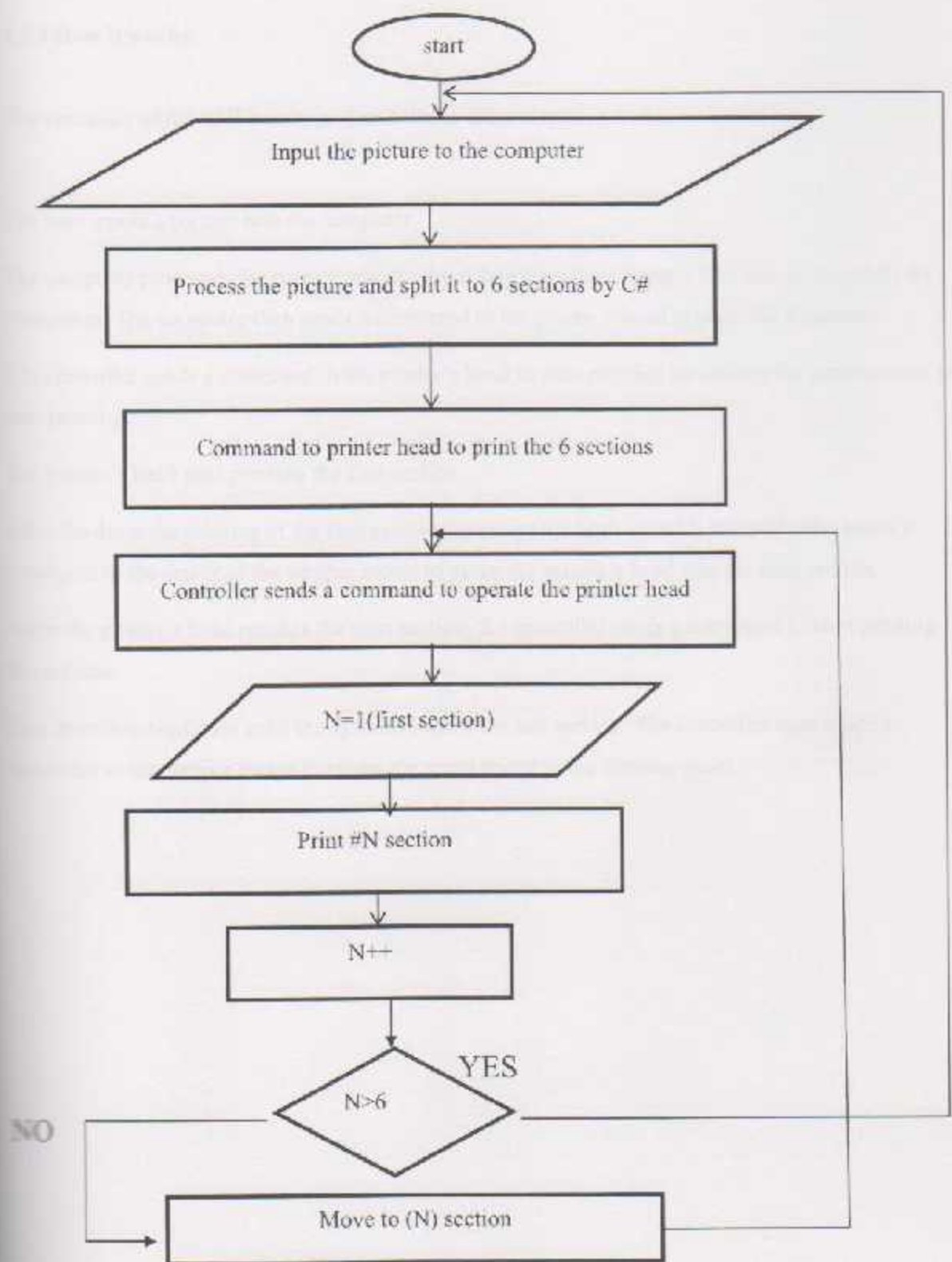

Figure 3.17: Flow chart

3.4.3 How it works

The operation of the wall printer project follows these steps:

- 1) The user inputs a picture into the computer.
- 2) The computer processes the picture and divides it into 6 sections using a C# code, or manually by Photoshop. The computer then sends a command to the printer's head to print the 6 sections.
- 3) The controller sends a command to the printer's head to start printing by closing the paper sensor to start printing.
- 4) The printer's head start printing the first section.
- 5) After finishing the printing of the first section (interrupt the limit switch), the controller sends a command to the driver of the stepper motor to move the printer's head into the next section.
- 6) When the printer's head reaches the next section, the controller sends a command to start printing this section.
- 7) This operation continues until the system reaches the last section. The controller then sends a command to the stepper motor to return the small frame to the Starting point.

3.5 Drawings for the project

This section will show some figure of the design for the design of the wall printer.

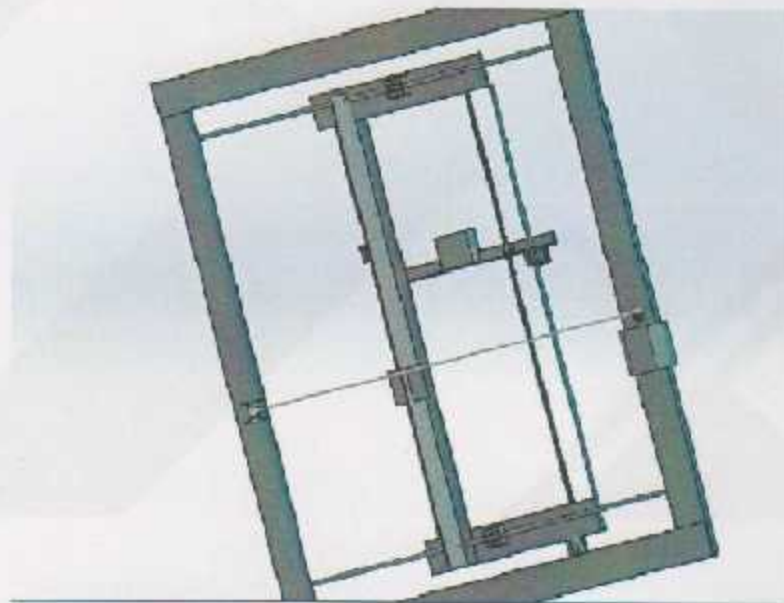

Figure 3.18: Frame layout

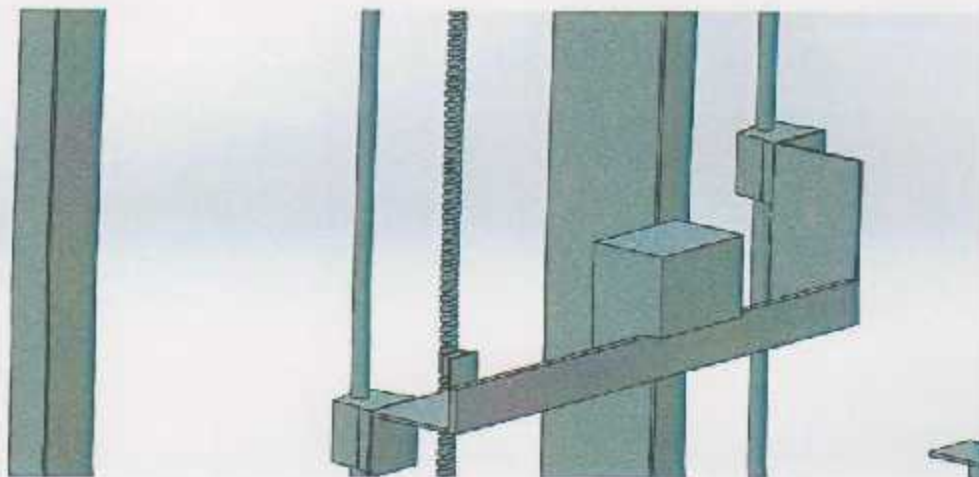

Figure 3.19: printer head

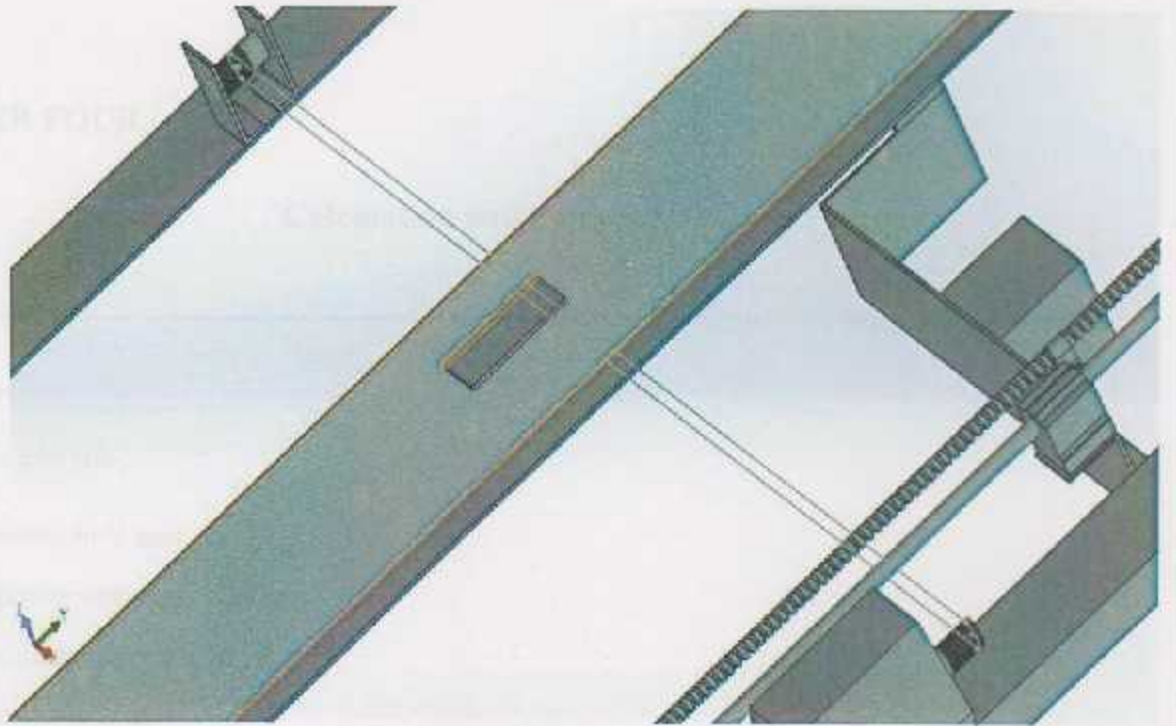

Figure 3.20: mechanism of the motion

CHAPTER FOUR

Chapter 4

Calculation and analysis

4.1 introductions

4.2 Dynamic analysis

4.2.1 The motion in Y axis

4.2.1.1 power screw mechanism

4.2.1.2 calculating required torque

4.2.2 The motion in X axis

Chapter 4

Calculation and analysis

4.1 Introduction

This chapter will show the dynamic analysis and the calculations for the torque required for the motion in the two coordinate, and finally the software analysis.

4.2 Dynamic analysis

This section will describe the dynamic analysis and the calculations for the motion in the two coordinate X, Y.

4.2.1 The motion in Y axis

Power screw mechanism will be used in the Y axis motion, because the motion in this axis will be affected by the Gravity, so the system must to be stable while the motor running and after stopped the motor, so the power screw mechanism is the optimal method for solving this problem.

4.2.1.1 Power screw mechanism

Power screw mechanism used to convert the rotary motion that generated by the motor into a linear motion in the Y axis to raise or lower the load. It produces uniform motion and the design of the power screw is to be as the nut is held at rest and the screw that rotates. The nut is moves axially along the screw in which the nut is fixed with the members [12].

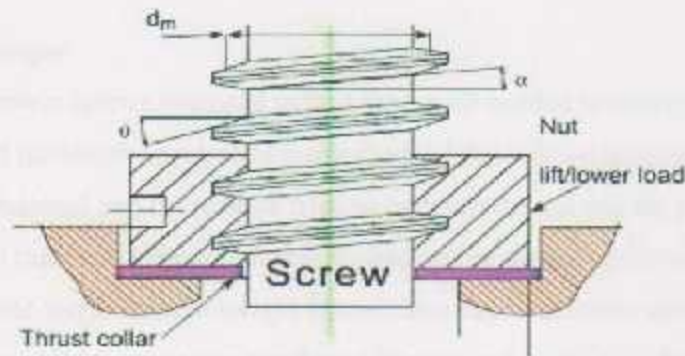

Figure 4.1: power screw

Where: θ is the thread angle and α is the face or the lead angle. The nut is coupled to perform a precise positioning.

In our project the Trapezoidal Screw will be used, because the trapezoidal screws are more popular in CNC machines. The shape of the trapezoidal with a wider base of the tooth gives it a better carrying of loads. The trapezoidal screw has high efficiency and low friction forces and low radial loads. Trapezoidal screws are combined with trapezoidal nuts to perform an optimum performance.

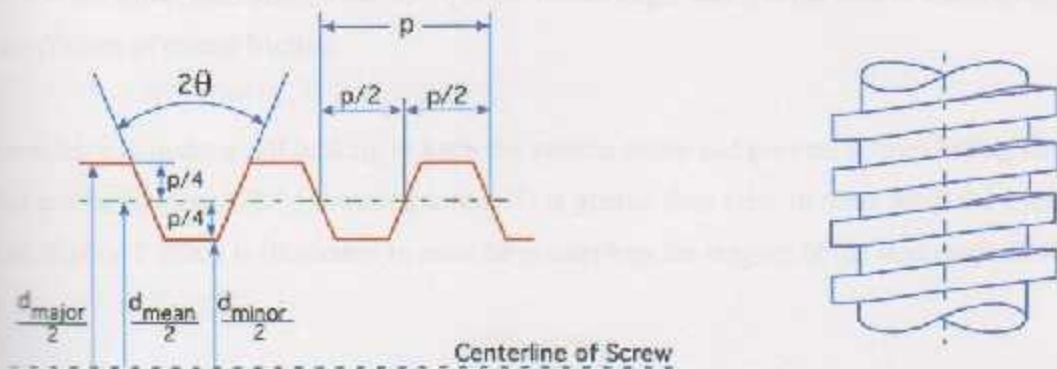

Figure 4.2: Trapezoidal Screw

Where: θ is the thread angle and p is the distance between two adjacent threads. And d is diameter.

4.2.1.2 Calculating torque

As an application of power screws, we need to find the torque needed to move the forces applied on Y axis. The forces and the torque required to move the load depends on the geometry of the screws and the nature of the material and the relative friction between the nut and the power screw.

The torque required to raise and lower the forces is obtained by assuming the system is equilibrium by taking the forces need to weight forces, raise or lower forces and the friction forces. The raising torque is required to overcome the thread friction and to raise the load in vertical direction or to move the load in horizontal direction. The raising torque T_R is given by [13]

$$T_R = (F \cdot d_m / 2) \cdot (f \cdot \sec \theta + \tan \alpha) / (1 - f \cdot \sec \theta \cdot \tan \alpha) \quad (4.1)$$

The lowering torque required to lower the load and to overcome the a part of friction T_L is found to be

$$T_L = (F \cdot d_m / 2) \cdot (f \cdot \sec \theta - \tan \alpha) / (1 + f \cdot \sec \theta \cdot \tan \alpha) \quad (4.2)$$

Where: F is the force, d_m is mean diameter, θ is the thread angle and α is the face or the lead angle, f is the coefficient of thread friction.

The screw have to make a self locking to keep the system stable and prevent it from falling down, And that can be happened if the lowering torque T_L is greater than zero, in other word the coefficient of thread friction f which is illustrated in must be greater than the tangent of the lead angle shown in Figure 4.3.

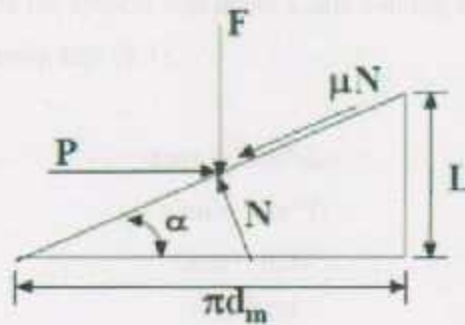

Figure 4.3: lead angle [12]

Where L is the screw lead that demonstrates the traveling distance of the nut when the screw shaft makes one rotation.

$$\tan \alpha = L / (\pi * d_m) \quad (4.3)$$

To make sure that the screw will make self locking the coefficient of thread friction f it must be $f > \tan \alpha$.

The specification of the screw that will be used in our project:

Major diameter: 8mm

Minor diameter: 6mm

Mean diameter: 7mm

Pitch (p): 2mm

Lead (L): 2mm

Thread angel (θ): 30°

The coefficient of thread friction (f): 0.2[12]

First step we have to make sure the system will make a self holding or not, so we have to calculate the tangent of the lead angle using Eqs (4.3).

$$\tan\alpha = L/(\pi*d_m)$$

$$\tan\alpha = 2/(\pi*7)$$

$$\tan\alpha = 0,09$$

$$0,2 > 0,09$$

So the system will make a self holding.

Second step is to calculate the required torque to rise and lower the printer head, so to apply the Eq (4.1) we have to calculate the force (F).

$$F = m*(g+a)$$

Where: m is the mass of the small frame with printer head and it assumed to be 6Kg.

g: the acceleration of the gravity (9.81m/sec²).

Notice that a is the acceleration component of raising or lowering the load, using a stepper motor with a maximum velocity of 300RPM and an acceleration time 0.1sec, we get a linear velocity and an acceleration of the nut installed on the screw. The linear velocity v is

$$V = L*N$$

$$V = 0.002*5 = 10\text{mm/s}$$

$$a = v/t = 10\text{mm/s}/0.1 = 0.1\text{m/s}$$

$$F = 6*(9.81+0.1)$$

$$F = 59.46\text{N}$$

For more safety let us assume F=60N.

By applying the Eq(4.1) we can find the rising torque.

$$T_r = (60*0.007/2)*(0.19*\sec 15^\circ + 0.09)/(1 - 0.19*\sec 15^\circ*0.09)$$

$$T_R = 0.06 \text{ N.m}$$

$$T_R = 6.98 \text{ N.cm}$$

To find the total rising torque we will apply the following equation

$$T_T = T_R + T_a \quad (4.4)$$

Where: T_T is total rising torque and the T_a is Acceleration torque.

Now to calculate the Acceleration torque we have to find angular acceleration (γ) of the motion which it depend on the linear acceleration (a) and the diameter of the motor ($r=0.006\text{m}$)

a : the linear acceleration of the motion and it set to be 0.01 m/sec^2 at 750 mm/min

$$\gamma = a/r \quad (4.5)$$

$$\gamma = 0.01/0.006$$

$$\gamma = 1660 \text{ rad/sec}^2$$

Now by using the following equation we can find T_a

$$T_a = \gamma * J_T$$

$$J_T = J_{\text{load}} + J_{\text{screw}}$$

And by using this equations we can find J_{load} & J_{motor} [14]

$$J_{\text{load}} = (m * p^2) / 4 * \pi^2 = 6.2 * 10^{-7} \text{ kg.m}^2$$

$$J_{\text{screw}} = 0.5 * m_{\text{screw}} * r^2$$

$$m_{\text{screw}} = 1.2 \text{ Kg}$$

$$J_{\text{screw}} = 28.1 * 10^{-7} \text{ kg.m}^2$$

$$J_T = 34.3 * 10^{-7} \text{ kg.m}^2$$

$$T_a = 1.6 \text{ N.cm}$$

Calculation total rising torque using Eq (4.4)

$$T_T = 6.98 + 1.6$$

$$T_T = 8.58 \text{ N.cm}$$

Motor torque to rise the load can be calculated by applying this equation

$$T_{\text{motor}} = T_T * K_s$$

$$T_{\text{motor}} = 17.6 \text{ N.cm}$$

Where: K_s is factor of safety ($K_s = 2.1$)

So the motor torque will be

By applying the Eq(4.2) we can find the lowering torque

$$T_L = (F * d_m / 2) * (f * \sec \theta - \tan \alpha) / (1 + f * \sec \theta * \tan \alpha)$$

$$T_L = (60 * 0.007 / 2) * (0.19 * \sec 15^\circ - 0.09) / (1 + 0.19 * \sec 15^\circ * 0.09)$$

$$T_L = 2.18 \text{ N.cm}$$

The value of the lower torque is a positive so the screw is self-locking and would not rotate under the action of the load.

Calculation total lowering torque using Eq (4.4)

$$T_r = 3.08 + 1.6 = 4.68 \text{ N.cm}$$

Motor torque to lower the load can be calculated by applying this equation

$$T_{\text{motor}} = T_r * K_s$$

Where: K_s is factor of safety ($K_s = 2.1$)

So the motor torque will be

$$T_{\text{motor}} = 9.36 \text{ N.cm}$$

4.2.2 The motion in X axis

Belt and pulley mechanism used for x-axis motion. The pulley diameter (D) is 16 mm. the load of mass (M) is the mass of small from with Y frame (total mass $M = 8 \text{ Kg}$), the mass of pulley (m_p) is 0.1Kg and the mass of belt m_b is 0.3Kg. The belt angle of inclination $\theta = 0$ and efficiency of mechanism $\mu = 0.9$.

To find the Acceleration torque first we have to find J_r : [14]

$$J_{\text{load}} = (1/4) * M * D^2 = 5.12 * 10^{-4} \text{ kg.m}^2$$

$$J_{\text{pulley}} = (1/8) * m_p * D^2 = 3.2 * 10^{-6} \text{ kg.m}^2$$

CHAPTER FIVE

$$J_{\text{belt}} = (1/4) * m_b * D^2 = 1.9 * 10^{-5} \text{ kg.m}^2$$

$$J_T = J_{\text{load}} + 2 * J_{\text{pulley}} + J_{\text{belt}} = 53.73 * 10^{-5} \text{ kg.m}^2$$

Now we can find acceleration torque by using $\gamma = 1660 \text{ rad/sec}^2$:

$$T_a = \gamma * J_T$$

$$T_a = 1660 * 53.73 * 10^{-5} = 18.92 \text{ N.cm}$$

Load torque T_L can be measure using this equation [14]

$$T_L = (M * g * D * (\sin \theta + \eta \cos \theta)) / 2\mu \quad (4.6)$$

$$T_L = 11.26 \text{ N.cm}$$

Where: η is Efficiency (Reference Value is 0.85 to 0.95.)

μ is Frictional coefficient of sliding surfaces

θ is Angle of inclination, $\theta=0$

Total torque required in the X axis:

$$T_i = T_a + T_L$$

$$T_i = 18.92 + 11.26 = 30.12 \text{ N.cm}$$

Motor torque by using factor of safety $K=1.2$:

$$T_m = K * T_i = 1.2 * 30.12 = 36.144 \text{ N.cm}$$

CHAPTER FIVE

Manufacturing and assembly

5.1 Introduction

5.2 Disassembly the printer

5.2.1 Remove the scanner unite

5.2.2 Removing the cover of the printer

5.2.3 Extraction the printer head

5.3 assembly of wall printer

5.3.1 Linear bearing motion installation

5.3.2 Linear guide motion and Y-axis installation

5.3.2.1 The frame of Y-axis

5.3.2.2 Flanged Block supporter installation

5.3.3 Y-axis stepper motor installation

5.3.4 Lead screw installation

5.3.4.1 Coupler installation

5.3.4.2 Mounted ball bearing installation

5.3.4.3 Screw nut installation

5.3.5 Installation the frame of X-axis

5.3.5.1 Linear bearing motion installation

5.3.5.2 Linear guide motion installation

5.3.6 X-axis stepper motor installation

5.3.7 Timing pulley installation

5.3.8 Open end timing belt

5.3.9 Optical limit switch installation

5.3.10 vacuum holder installation



Chapter 5

Manufacturing and assembly

5.1 Introduction

This chapter shows how we manufacturing and assembly the whole components of our project step by step.

5.2 Disassembly the printer

The first step in wall printer project is the extraction the printer head from the A4 printer and make sure that the printer head is work probably. So we begin with disassembly the printer.

5.2.1 Remove the scanner unite

The first step is removing the scanner form the printer, because the seamer is the top side of the printer so it should be removes in the first.



Figure 5.1: removing the scanner unite



Figure 5.2: after removing the scanner unite

5.2.2 Removing the cover of the printer

We have to remove the cover of the printer to be able to extract the printer head.



Figure 5.3: removing the cover

5.2.3 Extraction the printer head

The next step is extraction the printer head, its driver and the ink tank from the printer.



Figure 5.4: extraction the printer head

5.3 assembly of wall printer

This section shows how we connected the parts of our project with each other, and show the whole frame of our project and its properties.

5.3.1 Linear bearing motion Installation

In this stage the linear bearing motion has been connected to the printer head, by aluminum holder. And we use a 3mm screw to fix the bearing with these holder. Then we put the linear shaft motion inside the bearing to get a smooth motion.



Figure 5.5: connect the bearing with printer head

5.3.2 Linear guide motion and Y-axis installation

The linear guide motion has to be fixing to the Y-axis to make sure that the motion still smoothly in the Y-axis. So connection between them has to be a good connection. So we use Flanged Block supporter.



Figure 5.6: Linear guide motion and Y-axis installation

5.3.2.1 The frame of Y-axis

The frame of Y-axis has been made by aluminum, because it easy to machine and it has a light weight.

5.3.2.2 Flanged Block Supporter installation

This supporter used to fix the linear guide motion with the frame, and is used to keep the linear guide motion in the right position. And it installed by 4mm screw.

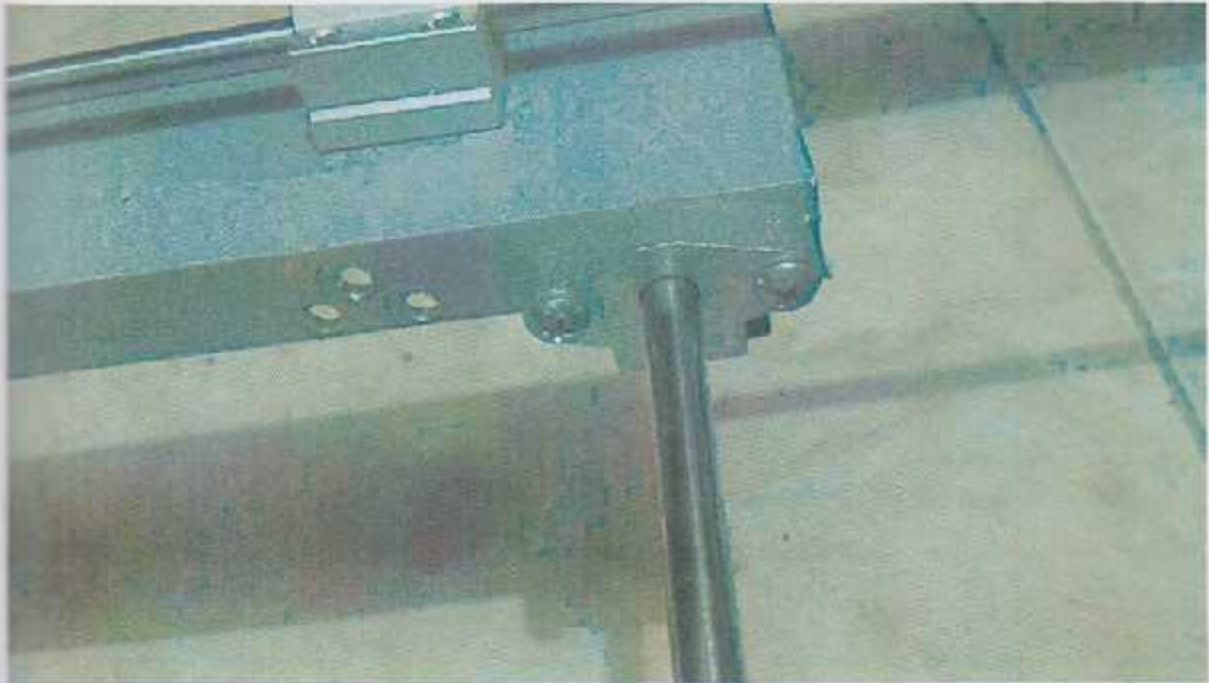

Figure 5.7: Flanged Block Supporter installation

5.3.3 Y-axis Stepper motor installation

The stepper motor has been fixed by a holder on the Y-axis frame to move the printer head vertically.



Figure 5.8: Y-axis Stepper motor installation

5.3.4 Lead screw installation

The motion in the Y-axis require a lead screw mechanism to prevent the printer head from falling down, because it make a self locking, so we use the lead screw mechanism.

5.3.4.1 Coupler installation

This coupler used to fix lead screw with stepper motor's shaft.



Figure 5.9: Stepper motor coupler installation

5.3.4.2 Mounted ball bearing installation

This bearing used to keep the lead screw in a straight line.

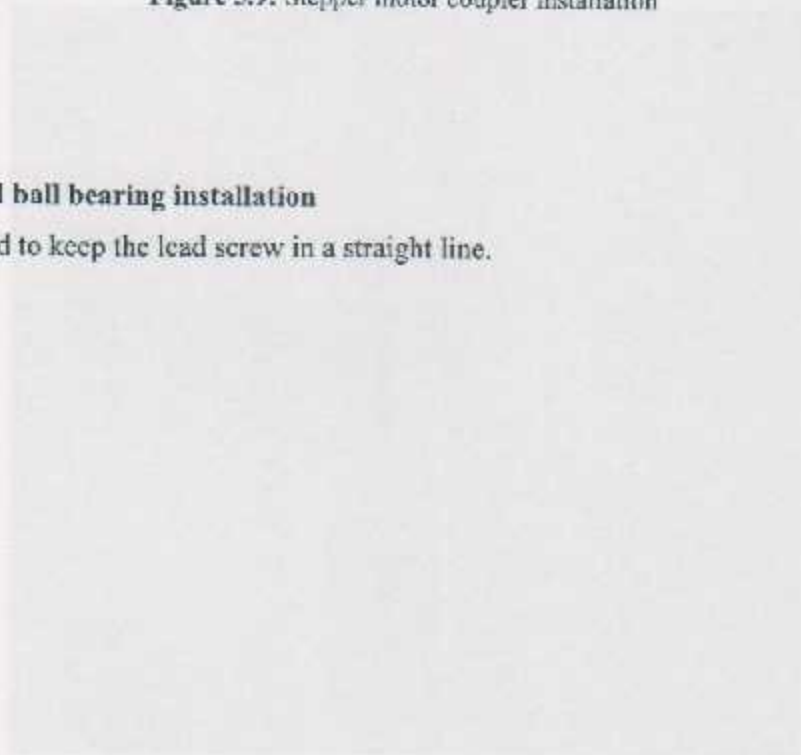

Figure 5.10: Mounted ball bearing installation



Figure 5.10: Mounted ball bearing installation

5.3.4.3 Screw nut installation

The screw nut used to fix the lead screw with the printer head to move it in the Y-axis.



Figure 5.11: Screw nut installation

5.3.5 Installation the frame of X-axis

The frame of X-axis has been made by aluminum, because it easy to machine and it has a light weight.

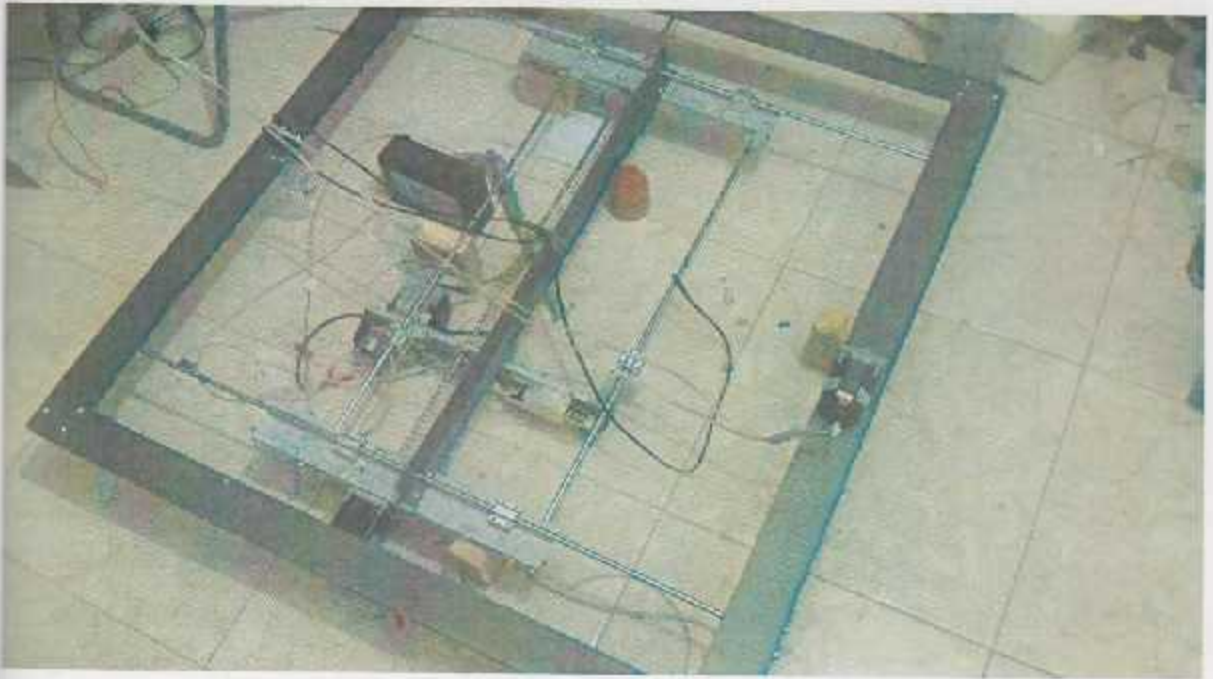

Figure 5.12: Installation the frame of X-axis

5.3.5.1 Linear bearing motion Installation

The Linear bearing motion Installation fixed in the Y-axis frame to Carrey it and make it able to move in the X-axis.



Figure 5.13: Linear bearing motion Installation

5.3.5.2 Linear guide motion installation

The linear guide motion has been placed in the linear bearing motion and fixed in the X-axis by the Flanged Block Supporter.



Figure 5.14: Linear guide motion installation

5.3.6 X-axis Stepper motor installation

This stepper motor used to move the vertical frame in the X-axis and it fixed in the X-axis by stepper motor holder.



Figure 5.15: X-axis Stepper motor installation

5.3.7 Timing Pulley installation

Two timing pulleys used in the belt pulley mechanism the first one fixed on stepper motor shaft, and the other one has been fixed in front of the first pulley on the X-axis frame by timing pulley holder.



Figure 5.16: Timing Pulley installation

5.3.8 Open-end Timing Belt

This belt used to connect the timing pulley with the vertical frame to move it in the X-axis as shown in Figure 5.12.



Figure 5.17: Open-end Timing Belt

5.3.9 Optical limit switch installation

Optical limit switch has been placed at the end of the printer head slider to interrupt when the printer head end printing a line, and send a feedback to the controller to move the stepper motor vertically down by one step.

CHAPTER SIX

5.3.10 Vacuum holder installation

Vacuum holder will carry the project and stuck it on the wall to print the whole panel on the wall, as shown in Figure 5.13.



Figure 5.18: Vacuum holder installation

CHAPTER SIX

Chapter 6

Testing and Calibration

6.1 Testing the printer

6.2 Testing the printer head

6.2.1 Printing one colored line

6.2.2 Solving the problem of printing a colored line

6.2.3 Printing an one colored A4 image

6.2.4 Printing two vertical colored A4 image

6.2.5 Printing two horizontal colored A4 image

6.3 Process the image by C#

Chapter 6

Testing and calibration

6.1 Testing the printer

Before controlling and testing the printer head we have to test the printer and printer head driver, so when we try to print a line we faced a problem with paper sensor, because the paper sensor prevent the process of printing, so we have to control the paper sensor, then we solve this problem by receiving a signal from the printer and send a command to dc motor by the controller to open the paper sensor and closed it.

6.2 Testing the printer head

The first step we have to test and understand the principle of work of the printer head to be able to control and move it to get the image.

6.2.1 Printing one colored line

When we tried to print a colored line we get the same line twice but with different color with vertical space (shown in **Figure 6.1**). Then we conclude that the process of color mixing occurs on the paper not inside the printer head, and the printer head has three regions of nozzles of each color, then we measured the distance between nozzles by measured the distance between the center of each line.



Figure 6.1: First testing of colored line

6.2.2 Solving the problem of printing a colored line

To solve the problem that we faced, we put an optical limit switch at the end of the printer head slider to get a feedback when the printer head end the printing a one stroke, then the optical limit switch send a signal to the arduino, then the arduino send a command to driver of stepper motor to move down the printer head by the value distance between two line.

6.2.3 Printing a one colored A4 image

After we print a one colored line we tried to print a full A4 colored image, by moving the printer head with the same distance between lines and we get the image as showing in Figure 6.2 and Figure 6.3.



Figure 6.2: printing a colored A4 image



Figure 6.3: first colored A4 image

6.2.4 Printing two vertical colored A4 image

In this test we calibrate the distance between two vertical images to get the two images as one unit.

And we did two tests, the first one we measure the vertical distance between the two images as shown in **Figure 6.4**.



Figure 6.4: vertical distance between the two images

And the next test we print the two images as a one unit as shown in Figure 6.5.



Figure 6.5: print two images as a one unit

6.2.5 Printing tow horizontal colored A4 Image

in this test we have to measure the distance between two horizontal images to move the printer head by this distance to get the two images as one unit as shown in **Figure 6.6**

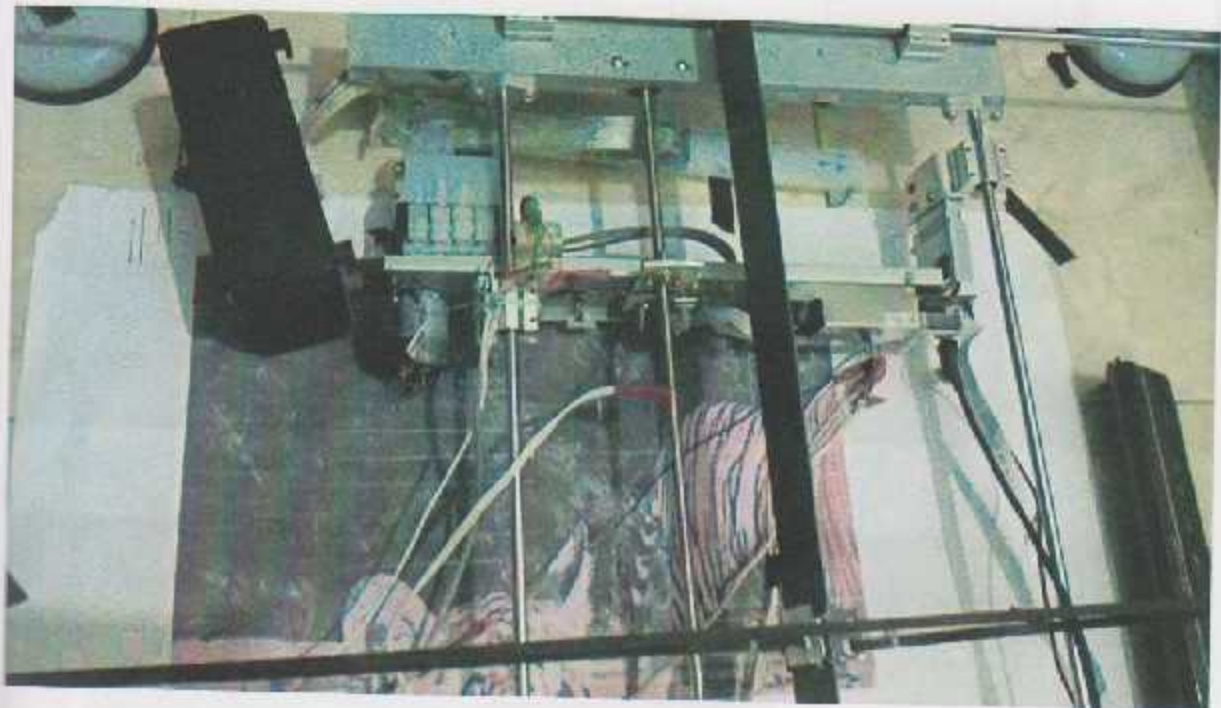

Figure 6.6: Printing tow horizontal images

6.3 Process the image by C#

We wrote a C# code to make interface window (shown in **Figure 6.7**) to upload the image (shown in **Figure 6.8**) then process it and split it to 6 sections then save these sections (shown in **Figure 6.9**) then send it to printing.

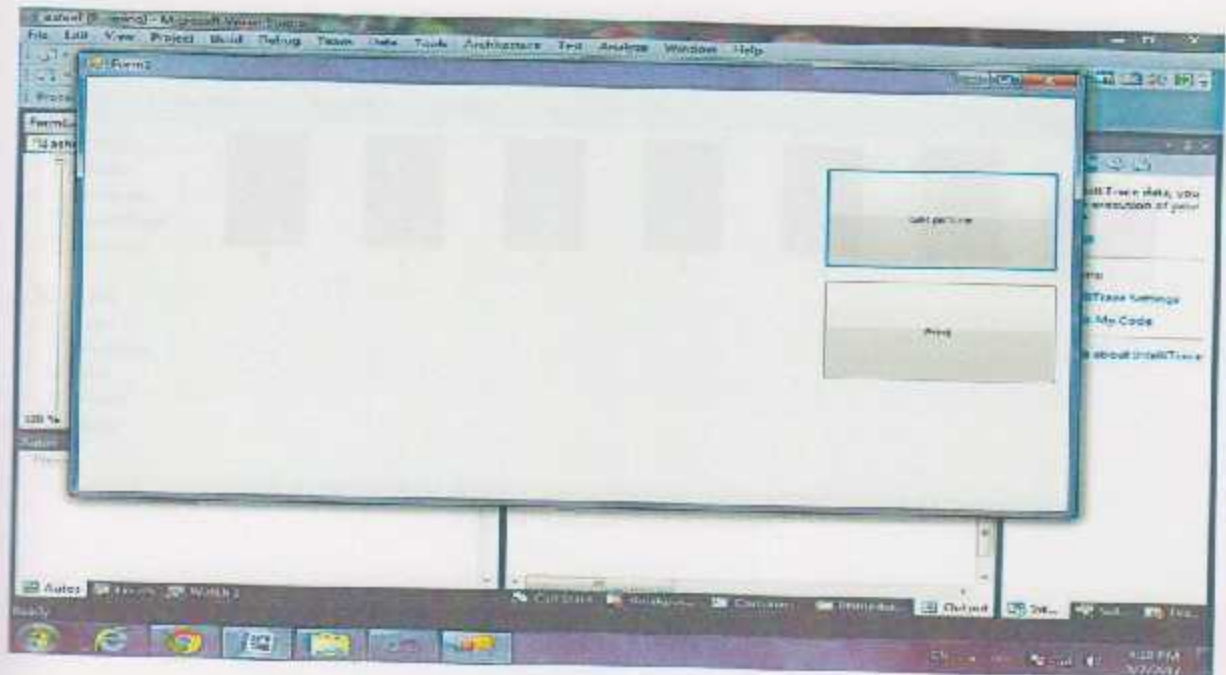

Figure 6.7: interface window

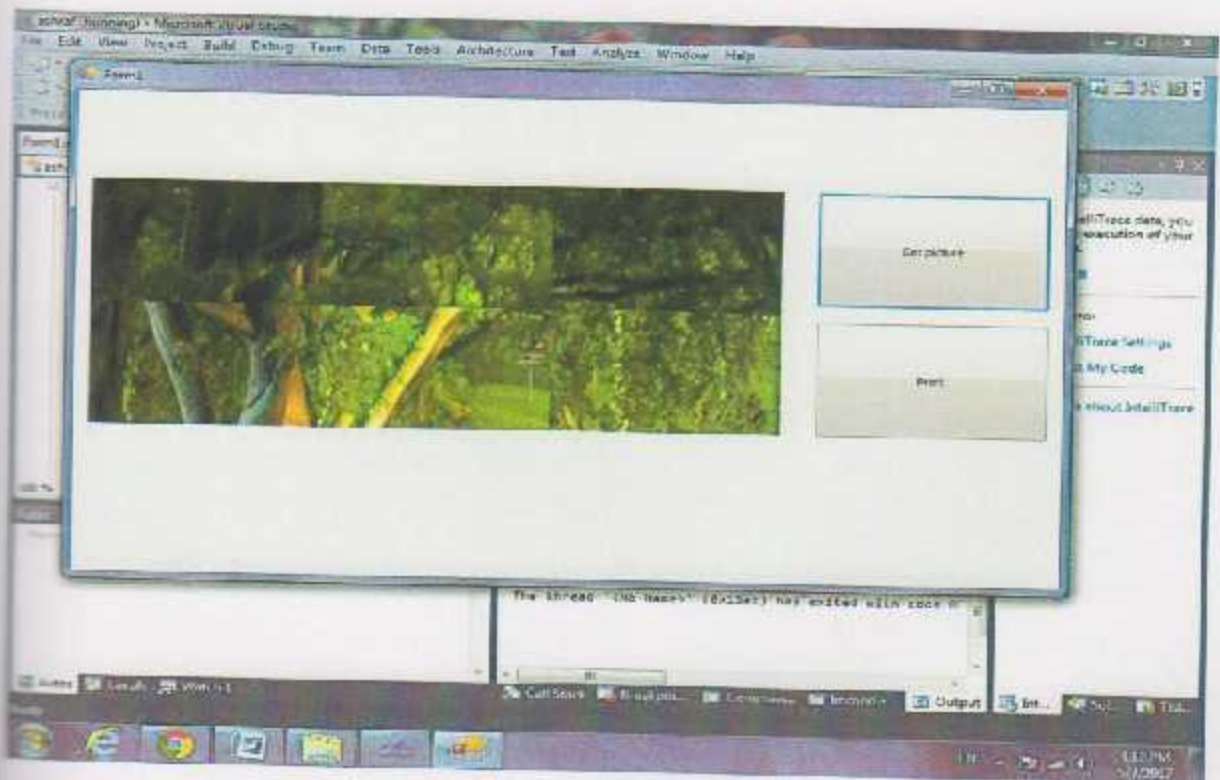

Figure 6.8: upload the image

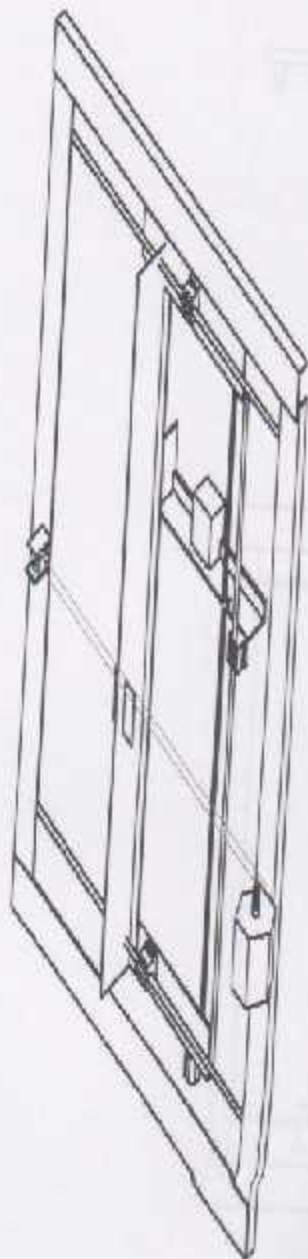

Figure 6.9: Save 6 sections

Appendix A *Design of Vertical Wall Printer*

Computer-Aided Drafting

A.1 Isometric view of Vertical Wall Printer



A.2 Orthographic Drawing of Vertical Wall Printer

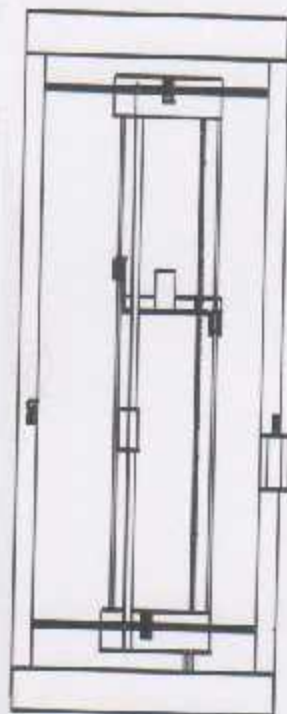
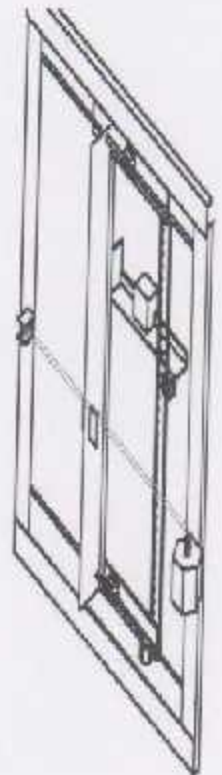
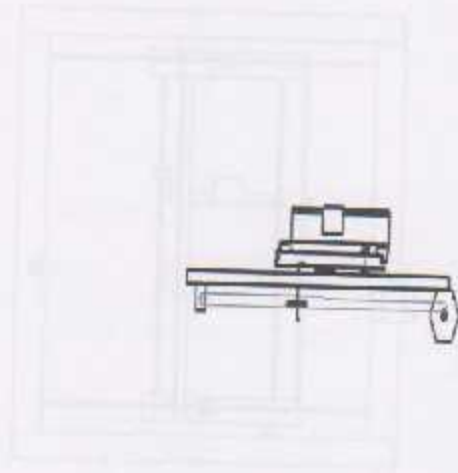

A.3 Front View of Vertical Wall Printer

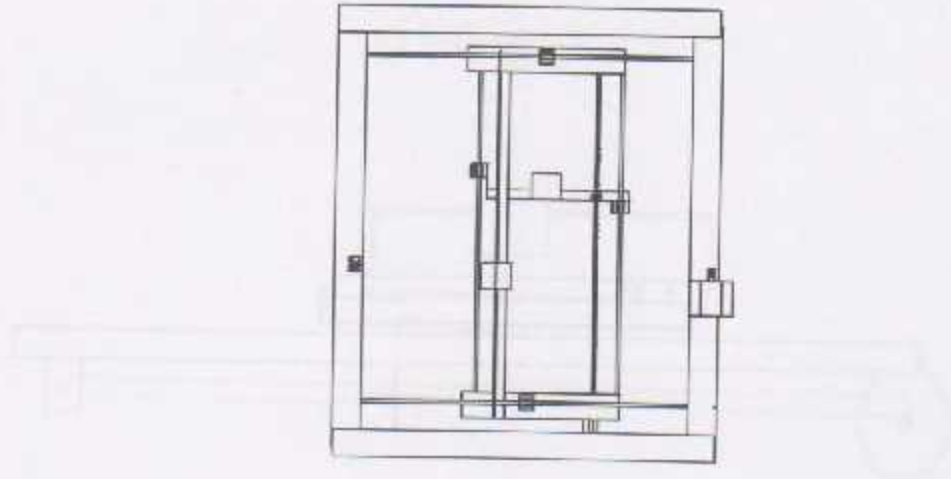

A.4 Side View of Vertical Wall Printer



A.5 Top View of Vertical Wall Printer

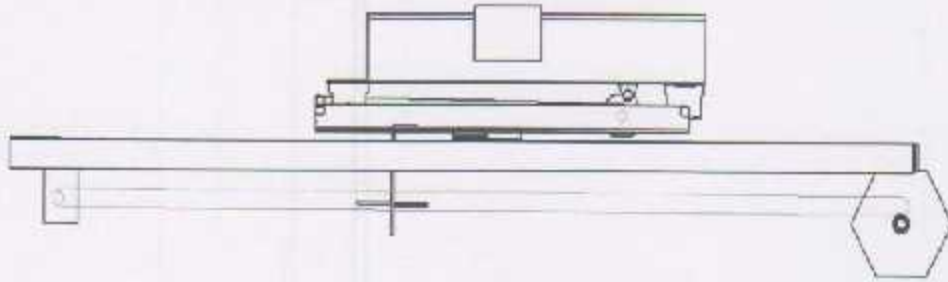

45 Orthographic Drawing of Beams

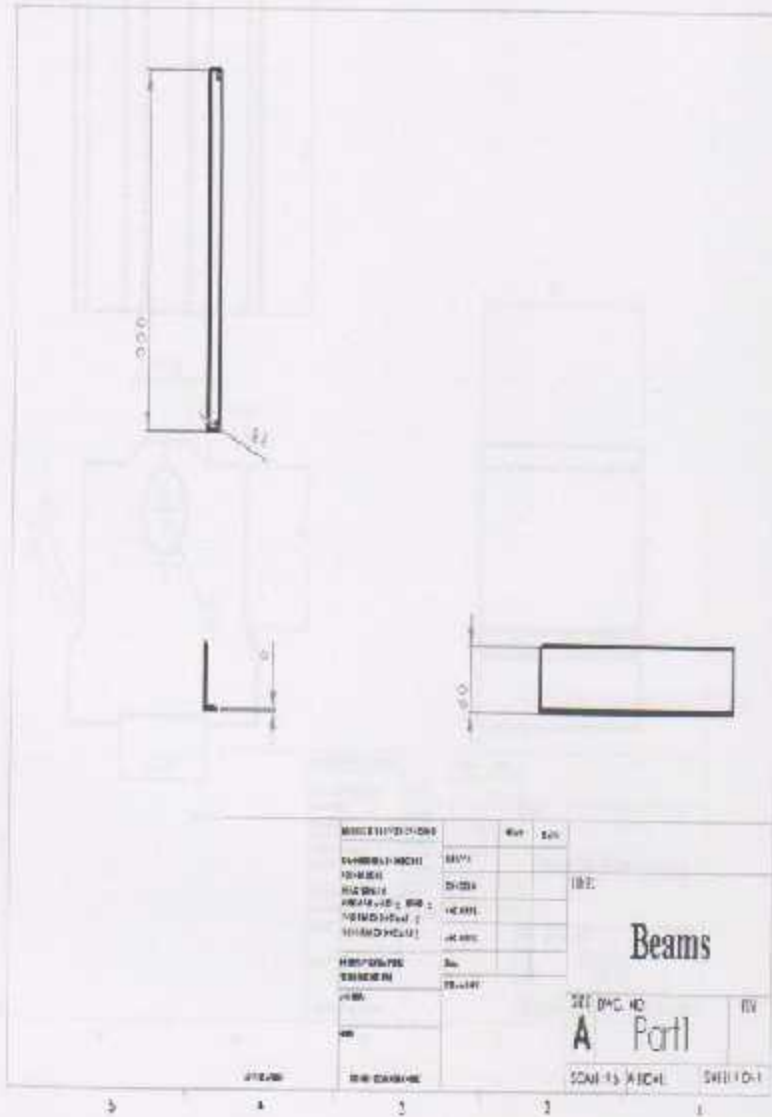

A.7 Orthographic Drawing of Linear Motion Bearing

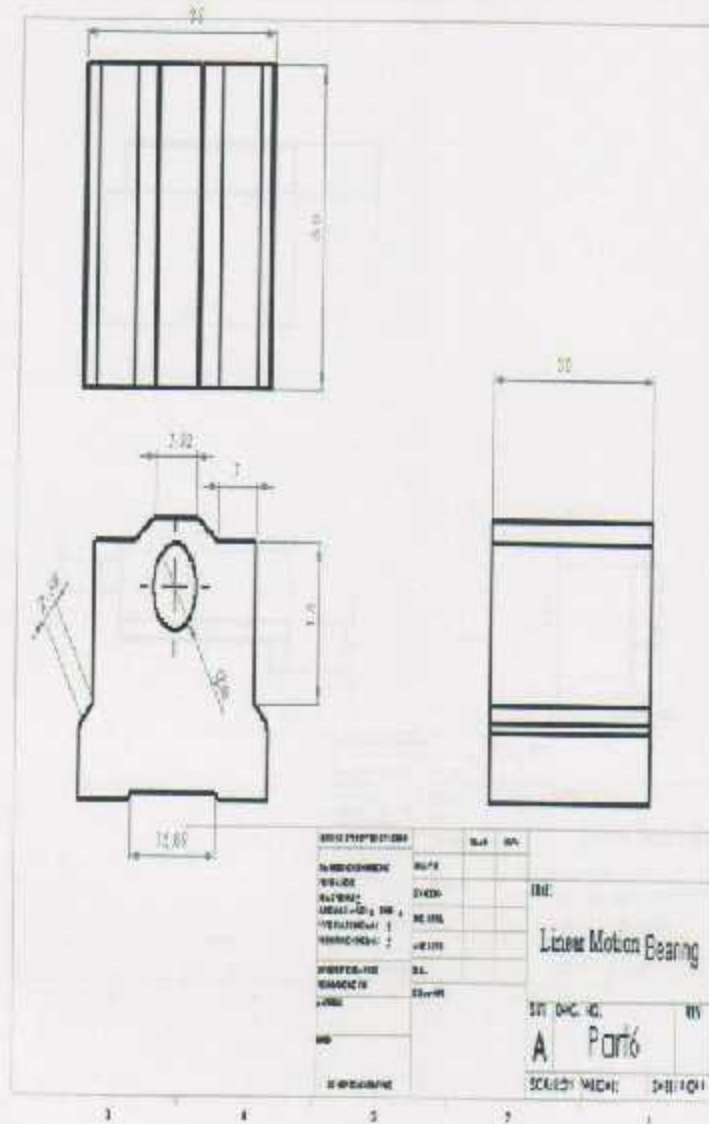

Orthographic Drawing of Printer Head Slider

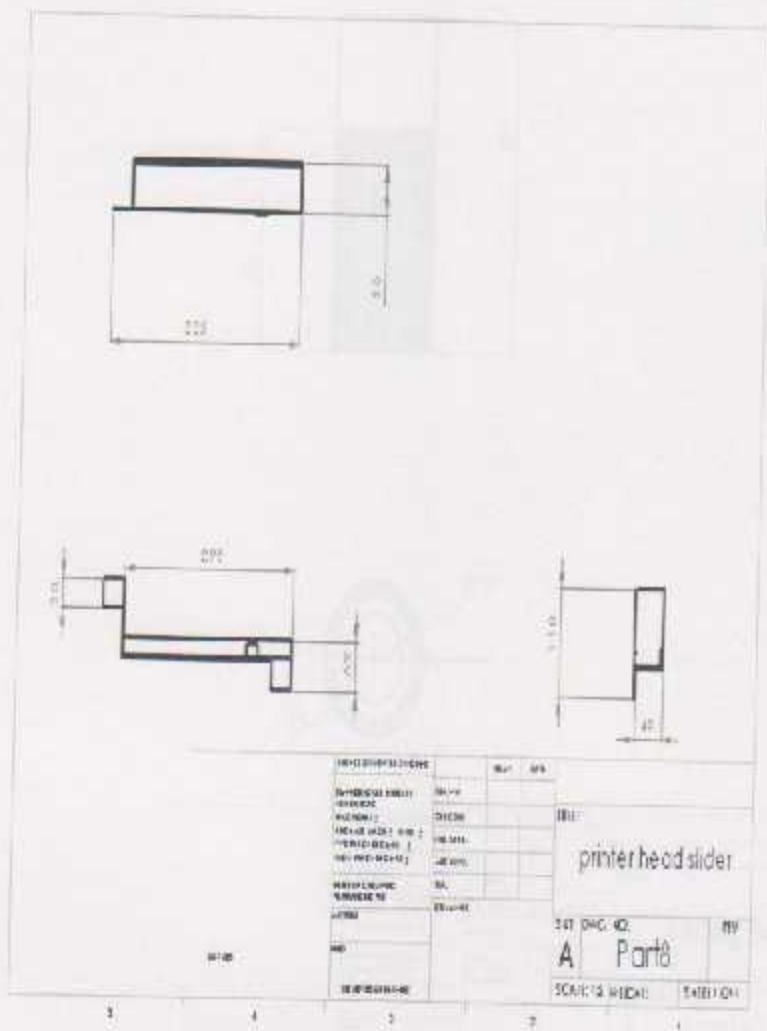

A.9 Orthographic Drawing of Timing Pulley

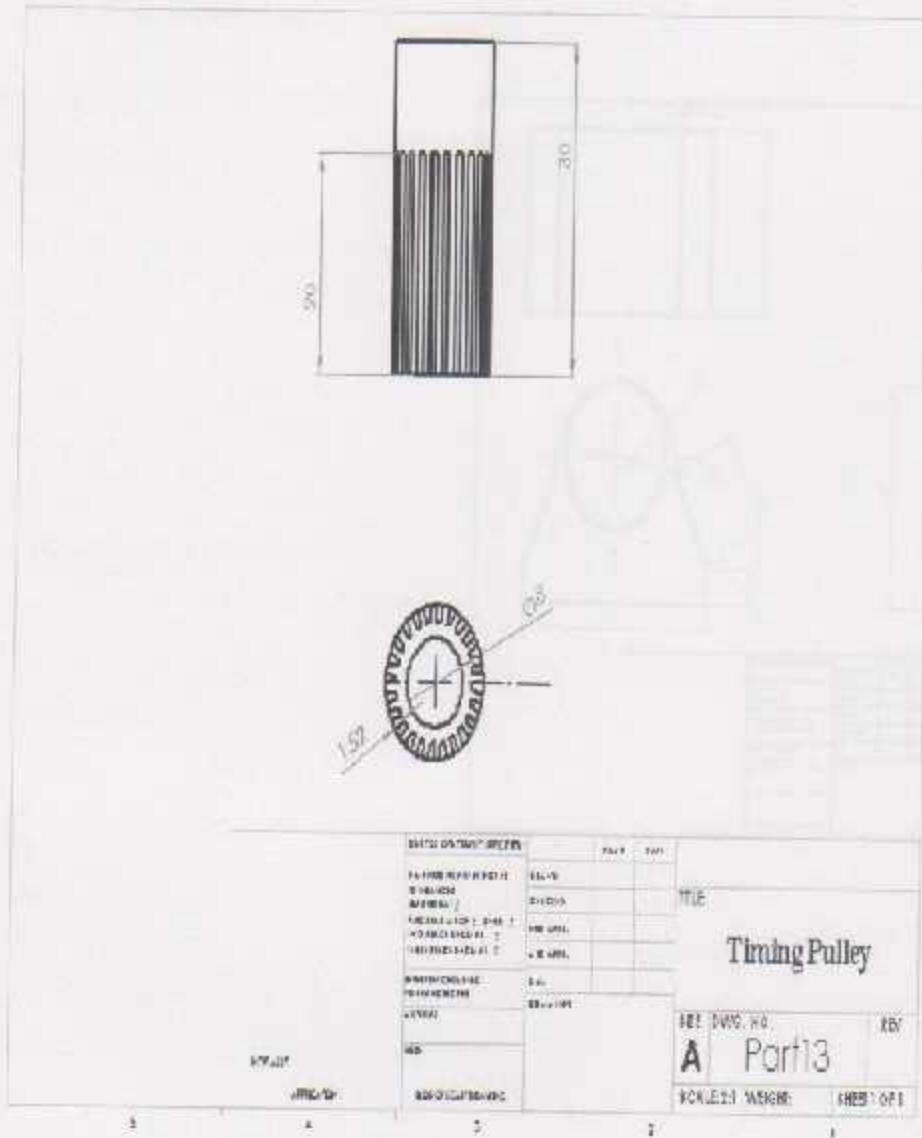

A.10 Orthographic Drawing of Screw nut

Electronic Components

1.1 Name of the component

Drawn by _____

Checked by _____

Date _____

Page No. _____

Roll No. _____

Class _____

Subject _____

Page No. _____

Date _____

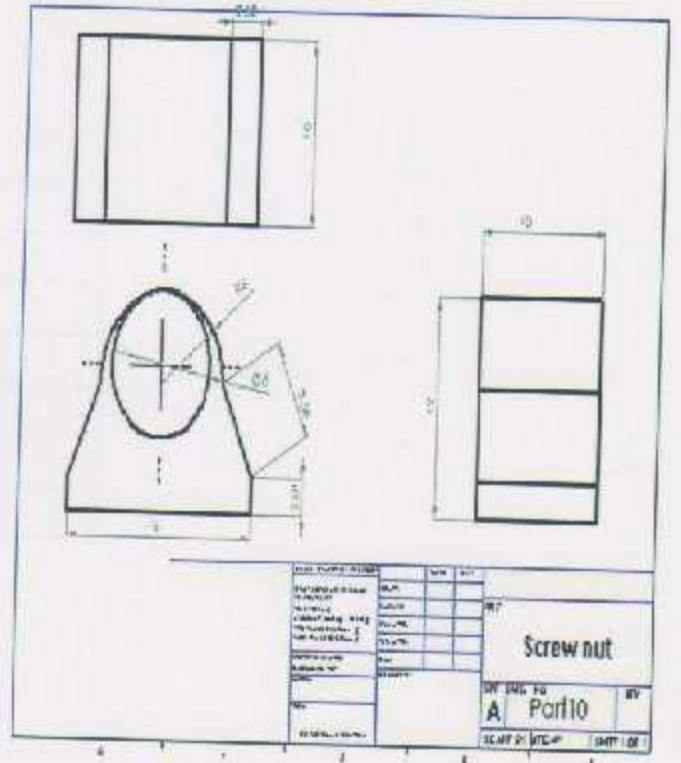

Appendix B

Electronic Components

B.1 Nema 23 for vertical motion

Electrical Specification

Manufacturer Part Number	23HS30-2804S
Motor Type	Bipolar Stepper
Step Angle	1.8°
Holding Torque	1.9Nm(269oz.in)
Rated Current/phase	3A
Phase Resistance	1.13ohms
Recommended Voltage	24-48V
Inductance	5.4mH±20%(1KHz)

Physical Specification

Frame Size	57 x 57mm
Body Length	76mm
Shaft Diameter	Φ8.35mm
Shaft Length	21mm
D-cut Length	15mm
Number of Leads	4
Lead Length	500mm
Weight	1.2kg

B.2 Nema 23 for horizontal motion

Electrical Specification

Manufacturer Part Number	23HS30-2804S
Motor Type	Bipolar Stepper
Step Angle	1.8°
Holding Torque	1.9Nm(269oz.in)
Rated Current/phase	1.25A
Phase Resistance	1.13ohms
Recommended Voltage	24-48V
Inductance	5.4mH=20%(1KHz)

Physical Specification

Frame Size	57 x 57mm
Body Length	76mm
Shaft Diameter	Φ6.35mm
Shaft Length	21mm
D-cut Length	15mm
Number of Leads	4
Lead Length	500mm
Weight	1.2kg

B.3 Stepper motor driver TB6560

Rated voltage: DC 12V-24V

Maximum current: 3A

Current adjustable (Current Settings): 0.5A, 1A, 1.5A, 1.8A, 2A, 2.5A, 3A

Subdivision adjustable (Excitation Mode): 1, 2, 8, 16

Attenuation adjustable (Decay Mode):

- 0 %-- no decay mode
- 25% of the slow decay mode
- 50% of the normal mode
- 100% -- Fast Decay mode
- Decay mode of regulation by different motors to match impedance, thereby eliminating the noise when locked stepper motor and motor movement in the shake.

Automatic half current setting (Torque Settings):

- 0%---- No pulse when the current 20 to normal operating current of 20%
- 50 %---- no pulse current 50% to normal operating current
- 75 %---- no pulse current 75% to normal operating current
- 100% --- no pulse when the current 100% to normal operating current

Appendix C

B.4 Arduino Mega specifications

Microcontroller	ATmega1280
Operating Voltage	5V
Input Voltage (recommended)	7-12V
Input Voltage (limits)	6-20V
Digital I/O Pins	54 (of which 15 provide PWM output)
Analog Input Pins	16
DC Current per I/O Pin	40 mA
DC Current for 3.3V Pin	50 mA
Flash Memory	128 KB of which 4 KB used by bootloader
SRAM	8 KB
EEPROM	4 KB
Clock Speed	16 MHz

Memory

The ATmega1280 has 128 KB of flash memory for storing code (of which 4 KB is used for the bootloader), 8 KB of SRAM and 4 KB of EEPROM.

Appendix C

E.1 C# code

```
using System;
using System.Collections.Generic;
using System.ComponentModel;
using System.Data;
using System.Drawing;
using System.Drawing.Drawing2D;
using System.Drawing.Imaging;
using System.Linq;
using System.Text;
using System.Threading.Tasks;
using System.Windows.Forms;

namespace ashraf
{
    public partial class Form1 : Form
    {
        public static Bitmap ResizeImage(Image image, int width, int height)
        {
            var destRect = new Rectangle(0, 0, width, height);
            var destImage = new Bitmap(width, height);

            destImage.SetResolution(image.HorizontalResolution, image.VerticalResolution);

            using (var graphics = Graphics.FromImage(destImage))
            {
                graphics.CompositingMode = CompositingMode.SourceCopy;
                graphics.CompositingQuality = CompositingQuality.HighQuality;
                graphics.InterpolationMode = InterpolationMode.HighQualityBicubic;
                graphics.SmoothingMode = SmoothingMode.HighQuality;
                graphics.PixelOffsetMode = PixelOffsetMode.HighQuality;

                using (var wrapMode = new ImageAttributes())
                {
                    wrapMode.SetWrapMode(WrapMode.TileFlipXY);
                    graphics.DrawImage(image, destRect, 0, 0, image.Width, image.Height,
                    GraphicsUnit.Pixel, wrapMode);
                }
            }

            return destImage;
        }

        private static Image cropImage(Image img, Rectangle cropArea)
        {
            Bitmap bmpImage = new Bitmap(img);
            Bitmap bmpCrop = bmpImage.Clone(cropArea,
            System.Drawing.Imaging.PixelFormat.DontCare);
            return (Image)(bmpCrop);
        }

        public Form1()
        {
            InitializeComponent();
        }
    }
}
```

E.1 C++ code(arduino)

```
const int buttonPin = 2; //feedback from printer
const int ope = 3; //open paper sensor
const int fla = 12; // feedback from optical limit switch
const int en = 4; // enable for Y stepper motor
const int dir = 5; // dir for Y stepper motor
const int stp = 6; // steps for Y stepper motor
const int enx = 7; // enable for X stepper motor
const int dirx = 8; // dir for X stepper motor
const int stpx = 9; // steps for X stepper motor
const int clo = 10; // closed the paper sensor

int buttonState = 0;

int i=0;

int flag=0;

int f=0;

int m=0;

void setup() {

    Serial.begin(9600);

    pinMode(ope, OUTPUT);
    pinMode(en, OUTPUT);
    pinMode(dir, OUTPUT);
```

```

pinMode(stp, OUTPUT);

pinMode(buttonPin, INPUT);
pinMode(fl, INPUT);
}

void loop()
{
while (m<=1){

buttonState = digitalRead(buttonPin); //feedback from the printer

if (buttonState == HIGH)
    i++;

if(i>=1){
delay(350);
digitalWrite(ope, HIGH); //opening the paper sensor

digitalWrite(en, HIGH);
digitalWrite(dir, HIGH); //direction down
while(i>=1){

```

```

flag = digitalRead(flA);
if (flag == LOW)
{
  f++;
  if(f==2){ //move stepper motor down step
    for (int n = 0; n <3333 ; n++) {
      digitalWrite(stp, HIGH);
      delayMicroseconds(23);
      digitalWrite(stp, LOW);
      delayMicroseconds(23); }
    while(f<=31){ //move stepper motor down for 31 steps
      flag = digitalRead(flA);
      if (flag == LOW)
      {
        digitalWrite(stp, HIGH);
        delayMicroseconds(23);
        digitalWrite(stp, LOW);
        delayMicroseconds(23); }
      while(flag == LOW){
flag = digitalRead(flA);
      }
      f++;
    }
}

```

```

    }
    digitalWrite(ope, LOW);
    digitalWrite(clo, HIGH); //closed paper sensor
    delay(300);
    digitalWrite(clo, LOW);

    delay(5000);
    i=0;
    digitalWrite(dir, LOW); //direction up
    f=0;
    m++;
    for (int n = 0; n <5833 ; n++) { //move the stepper motor up to the last image
    digitalWrite(stp, HIGH);
        delayMicroseconds(50);
    digitalWrite(stp, LOW);
        delayMicroseconds(50); }
    delayMicroseconds(250);
    digitalWrite(stp, LOW);
    }

    while(flag == LOW){
    flag = digitalRead(fl);
    }

```

```

}
}
}
}
digitalWrite(dir, LOW);
m=0;
for (int l = 0; l < 74 ; l++) { // move the stepper motor up at starting point
for (int n = 0; n < 3333 ; n++) {
digitalWrite(stp, HIGH);
delayMicroseconds(150);
digitalWrite(stp, LOW);
delayMicroseconds(150); }
}
digitalWrite(dirx, LOW); //direction to the right
for (int n = 0; n < 16832 ; n++) { //move the stepper motor X to the next image horizontal
digitalWrite(stpx, HIGH);
delayMicroseconds(150);
digitalWrite(stpx, LOW);
delayMicroseconds(150); }
}

```

C++ flow chart:

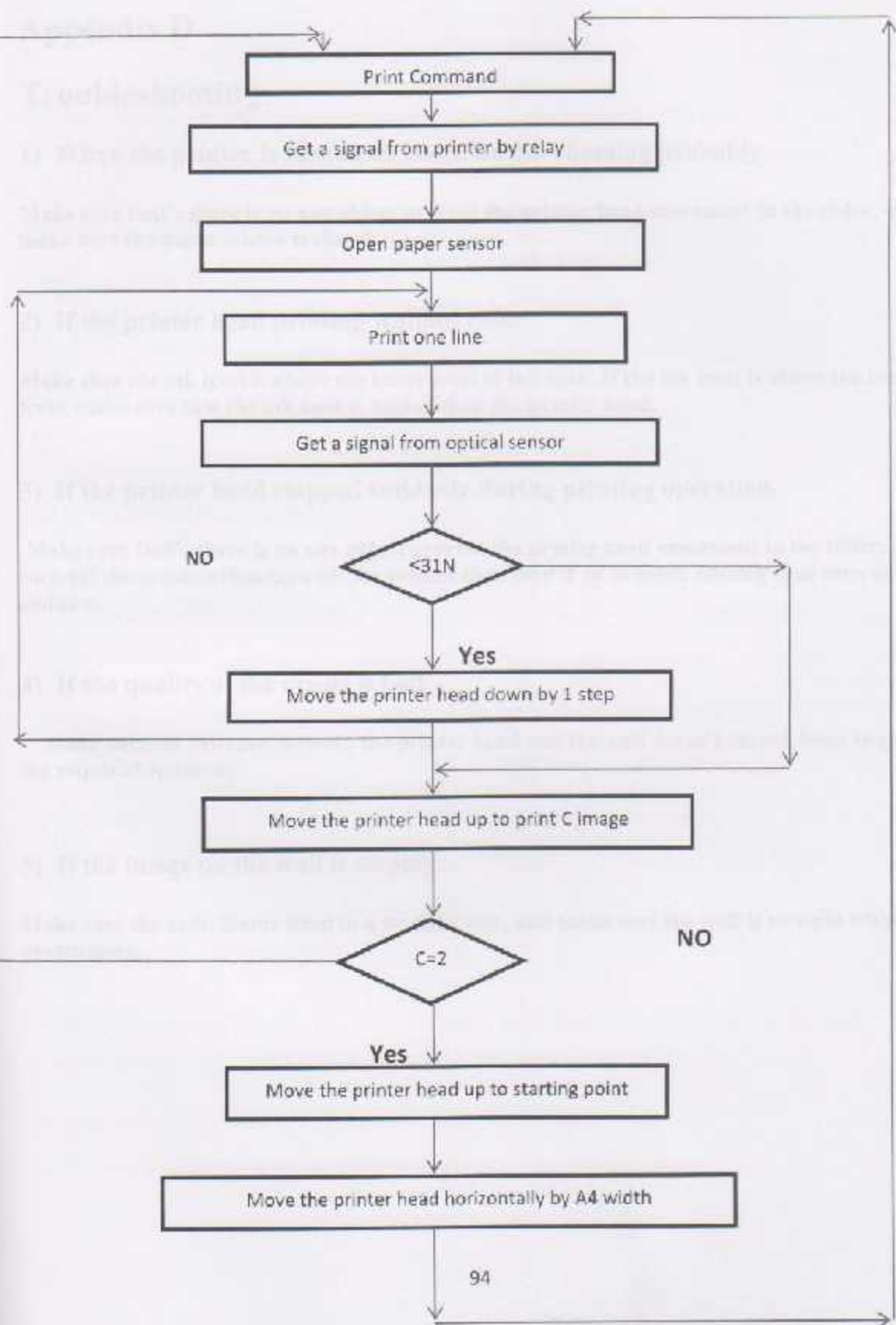

Appendix D

Troubleshooting:

1) When the printer is turned on and it doesn't homing probably.

Make sure that's there is no any object prevent the printer head movement in the slider, and make sure the paper sensor is closed.

2) If the printer head printing without color.

Make sure the ink level is above the lower level of ink tank. If the ink level is above the lower level, make sure that the ink tank is higher than the printer head.

3) If the printer head stopped suddenly during printing operation.

Make sure that's there is no any object prevent the printer head movement in the slider, and turn off the arduino then turn off the printer then turn it on to make homing then turn on the arduino.

4) If the quality of the image is bad.

Make sure the distance between the printer head and the wall doesn't exceed 5mm to get the required Accuracy.

5) If the image on the wall is sloping.

Make sure the main frame fixed in a straight way, and make sure the wall is straight without protrusions.

References

- [1] Drawing CNC machine defecation (2013) available at www.instructables.com at link <http://www.instructables.com/id/How-to-make-a-XY-plotter-with-Makeblock/>
- [2] James Floyd Kelly, Patrick Hood-Daniel. Printing in Plastic: Build Your Own 3D Printer. Technology in action. Jun 2, 2011.
- [3] Wood carving CNC machine definition (2011) available at <http://www.cncroutersource.com/> in link <http://www.cncroutersource.com/cnc-woodworking.html>.
- [4] Type of printer head(2016) available at <http://www.escotal.com/> at link <http://www.escotal.com/printer.html>.
- [5] technology used in ink-jet printer head (February 26, 2014) available at <http://www.aldertech.com/> at link <http://www.aldertech.com/blog/piezoelectric-print-heads-vs-thermal-print-heads/>
- [6] Color system definition available at <http://www.colormatters.com/> at link <http://www.colormatters.com/color-and-design/color-systems-rgb-and-cmyk>.
- [7] Epson L355 specifications (2016) available at www.sulekha.com at link <http://www.sulekha.com/printer/epson-l355-multifunction-printer-prices-and-specifications>.
- [8] stepper motor specifications (2014) available at reprap.org at link http://reprap.org/wiki/NEMA_23_Stepper_motor.
- [9] Driver of stepper motor The CWD556 datasheet available at www.cnc4you.co.uk at link <https://www.cnc4you.co.uk/Digital-DSP-Stepper-Driver-5.6Amp-50Volt-CWD556>.
- [10] Arduino Mega (2016) available at www.arduino.cc at link <https://www.arduino.cc/en/Main/arduinoBoardMega>.

[11] .M. Adithan. B.S. Pabla, CNC Machines. Technology in action 1997.

[12] power screw analysis available at www.slideshare.net at link
http://www.slideshare.net/Mohd_Limdi/power-screw-and-its-application.

[13] Jack A. Collins, Henry R. Busby, George H. Staab. Mechanical Design of Machine Elements and Machines. John Wiley & Sons, 2010.

[14] Babu & Sridhar . Design Of Machine Elements. ata McGraw-Hill Education, 2010