

# Palestine Polytechnic University



College of Engineering and Technology  
Mechanical Engineering Department

## Graduation Project

### Evaluation of Performance for Catalytic Converter to Reduce Toxic Emissions Exhaust from Internal Combustion Engines in Vehicles

#### Project Team

Ibrahim Ideas

Majdi Zama'reh

Moayed Al-Srahen

#### Project Supervisors

Dr.Zuhdi Salhab

Dr.Maher Al\_Ja'bari

Hebron-Palestine

Jun. 2010



## Abstract

This project comes as a response to the modern trends in the automotive world, which could be summarized into main factor, namely, the growing interests in the protection of the environment.

This project aims at Evaluation of Performance for Catalytic Converter to Reduce Toxic Emissions Exhaust from Internal Combustion Engines in Vehicles experimentally and measured experimentally using carbon monoxide (CO)sensors at the inlet and outlet of exhaust gas from catalytic converter .Since these sensors were not present in the vehicles before ,and development of catalytic converter by injection urea to reduce NOx emission .

## Table Of Contents

<u>Title</u>	<u>Page</u>
Cover	I
Project Team	II
Dedication	III
Acknowledgments	IV
Abstract	V
Table Of Contents	VI

## Chapter One

General Introduction .....	1
1.1 Introduction .....	2
1.2 Project Background .....	2
1.3 Project Scope .....	3
1.4 Project Goals and Objectives .....	4
1.4.1 General Goals .....	4
1.4.2 Specific Objectives.....	4
1.5 Project Choice Justification.....	5
1.6 Project Implementation Plan .....	6
1.6.1 Main Tasks and Activities .....	6
1.6.2 Time Table .....	7
1.7 Preliminary Budget .....	9

## Chapter Two

Internal Combustion Engine.....	10
2.1 Introduction .....	11
2.2 Interactions that Occur in the Internal Combustion Engines .....	11
2.2.1 Combustion Stoichiometry .....	11
2.2.2 Fuel Lean Mixture .....	13
2.2.3 Fuel Rich Mixture .....	13

2.3	Products of the Reaction .....	14
2.3.1	Nitrogen Oxides (NO <sub>x</sub> ).....	14
2.3.2	Hydrocarbons .....	15
2.3.2.1	Hydrocarbon Emission Sources.....	16
2.3.3	Carbon Monoxide .....	17
2.4	Emission Control .....	18

### Chapter Three

	Catalytic Converter .....	20
3.1	Introduction.....	21
3.2	Components of the Catalytic Converter .....	23
3.3	Work of The Catalytic Converter .....	25
3.4	Types of Catalytic Converter .....	27
3.5	Basic Emission Control Systems .....	29
3.6	Installation.....	32
3.7	Converter Operations .....	32
3.8	Causes of Catalytic Converter Plugging .....	33
3.9	Causes of Catalyst Fouling .....	34
3.10	Catalytic Converter Operating Efficiency .....	35

## Chapter Four

Sensor Concepts and Types .....	37
4.1 Introduction.....	38
4.2 Sensor Concept.....	38
4.3 Oxygen Sensor.....	39
4.3.1 How an Oxygen Sensor Works .....	40
4.4 Carbon Monoxide Sensor.....	42
4.5 Carbon Monoxide Sensor (TGS 822) .....	44
4.5.1 Sensitivity Characteristics .....	45
4.5.2 Structure and Dimension .....	46
4.5.3 Pin Connection and Basic Measuring Circuit .....	46
4.5.4 Basic Measuring Circuit.....	47
4.5.5 Standard Circuit Conditions .....	47
4.5.6 Standard Test Conditions .....	48

## Chapter Five

Injection Urea System.....	50
5.1 Background.....	51
5.2 Urea structure and Application.....	52
5.3 NO <sub>x</sub> Optimizer Injection of Urea CO(NH <sub>2</sub> ) <sub>2</sub> .....	53
5.3.1 Features and Benefits .....	53
5.3.2 NO <sub>x</sub> Reduction reaction.....	54
5.3.3 Urea Injection Requirements .....	54
5.3.4 Solution Experiment.....	54

## Chapter Six

Building Project and Result.....	55
6.1 Introduction .....	56
6.2 Principle Work of Project.....	56
6.3 Electrical System For Sensors.....	58
6.4 Data and Signal Handling.....	59
6.5 Efficiency of Catalytic Converter .....	60
6.5.1 Efficiency By Using Carbon Monoxide Sensors .....	60
6.5.2 Efficiency By Oxide of Nitrogen .....	65

## Chapter Seven

Conclusion and recommendation.....	69
7.1 conclusion.....	70
7.2 recommendation.....	71

## List of Tables

Table 1.1 Time Table for the First Semester.....	7
Table 1.2 Time Table for the Second Semester.....	8
Table 1.3 The Budget.....	9
Table 2.1 Effect and Mitigation Measures of Air Pollutants.....	17
Table 4.1 Standard Circuit Conditions.....	47
Table 4.2 Voltage Signal out from TGS at different condition.....	48
Table 4.3 Values of RS & PS at different condition .....	49

Table 6.1 CO Signal Versus Engine Speed (before and after catalytic) .....	59
Table 6.2 Efficiency of Cat.Conv Sensor to sensitivity of CO.....	61
Table 6.3 Construction of Emission Carbon Monoxide (CO), Carbon Dioxide (CO <sub>2</sub> ), Hydrocarbon (HC) .....	61
Table 6.4 NO <sub>x</sub> Versus Engine Speed (before and after Catalytic Converter w/o and with injection Urea).....	64
Table 6.5 Efficiency of System with and without Injection Urea to Reduce NO <sub>x</sub> .....	66

### List of Figures

Figure 2.1 Amount of emissions in exhaust and equivalence ratio.....	17
Figure 3.1 Catalytic Converters.....	22
Figure 3.2 modern catalytic converters .....	23
Figure 3.3 Oxidation and reduction process into catalytic converter.....	24
Figure (3"a,b,c").....	25
Figure 3.5 Inlet and outlet atom in catalytic converter .....	28
Figure 3.6 NO <sub>x</sub> emission versus engine speed .....	30
Figure 3.7 CO emission versus engine speed.....	31
Figure 3.8 HC emission versus engine speed .....	31
Figure 4.1 Oxygen Sensors.....	39
Figure 4.2 Oxygen sensor switching voltage.....	41
Figure 4.3 Feedback loop for lambda sensor.....	42
Figure 4.4 CO sensor.....	42
Figure 4.5 Sensor Response.....	43
Figure 4.6 TGS- 813.....	44
Figure 4.7 Sensitivity Characteristics.....	45



Figure 4.8 Structure and Dimension.....	46
Figure 4.9 simple circuit sensor.....	47
Figure 5.1 previous application of urea in diesel vehicles injection.....	51
Figure 5.2 previous application of urea injection in diesel motor .....	53
Figure 6.1 flow sheet of the project .....	57
Figure 6.2 Simple circuit for carbon monoxide sensor.....	58
Figure 6.3 Signal of CO sensor (in volt) versus engine speed before and after cat. Conv.....	60
Figure 6.4 CO emission versus engine speed (before and after catalytic converter).....	62
Figure 6.5 CO <sub>2</sub> emission versus engine speed (before and after catalytic converter).....	63
Figure 6.6 HC emission versus engine speed (before and after catalytic converter).....	63
Figure 6.7 NO <sub>x</sub> emission versus engine speed (before and after catalytic converter w/o and with injection urea).....	65
Figure 6.8 sample result data of the project by gas analyzer .....	66
Figure 6.9 picture of the project .....	67
Figure 6.10 Injection system of urea .....	67
Figure 6.11 Mixture Urea and water.....	68

# Chapter One

## General Introduction

- Introduction.
- Project Background.
- Project Scope.
- Project Goals and Objectives.
- Project Choice Justification.
- Project Implementation Plan.
- Preliminary Budget.

## 1.1 Introduction

As a result of development and technology that arrived to the world today and compete with another to impose its hegemony on the market for the best in the industry and marketing led to an increase in the number of vehicles largely, resulting in increased environmental pollution, so it must be found any way to reduce the environmental problems (emission control strategies) such as positive crankcase ventilation (PVC), exhaust gas recirculation (EGR), fuel tank canister purge, secondary air injection, spark timing adjustment and two way and three way catalytic converter [1].

Emissions contain many compounds, the main of them are carbon monoxide (CO), hydrocarbons (HC), and nitrogen oxides (NO<sub>x</sub>), these compounds produced when the combustion is not completely, so when the fuel is burned, emissions gases and compounds will be appeared, these compounds are dangerous for health and environment.

To reduce these emissions gases, a device will use to change its chemical construction; this device name is a catalytic converter.

In this project we will build an experimental set up to measure the amount of a toxic exhaust gases exit from internal combustion engines by using sensors at the inlet and outlet for catalytic converter, and injection urea (NH<sub>2</sub>)<sub>2</sub>CO in exhaust before catalytic converter to reduce NO<sub>x</sub>.

## 1.2 Project Background

An automotive catalytic converter is an emissions control device which may be incorporated into the exhaust system of a motor vehicle between the exhaust manifold and the muffler. The catalytic converter contains one or more catalysts, such as those based on platinum, palladium, or rhodium, which reduce the levels of hydrocarbons (HC), carbon monoxide (CO) and nitrogen oxides (NO<sub>x</sub>) in the exhaust gas, thereby reducing the amount of these pollutants which would otherwise be emitted into the atmosphere from the vehicle. In a typical commercial catalytic converter, (HC) and (CO) in the exhaust are oxidized to form carbon dioxide (CO<sub>2</sub>) and water, and (NO<sub>x</sub>) is reduced to nitrogen, carbon dioxide, and water.

## 1.3 Project Scope

The scope of the project is to build an experimental setup for evaluating the efficiency of catalytic converter, towards reducing emission of carbon monoxide, hydrocarbons and oxides of nitrogen. This includes the following main topics:

- Literature review of the industrial and component operation catalytic converter.
- Reviewing the scientific background about the raw materials, and properties of catalytic converter.
- Building experimental setup of carbon monoxide (CO) sensor at the inlet and outlet of the catalytic converter to measure the proportion of toxic gas.
- Developed catalytic converter to reduce the proportion of toxic gases by adding some materials such as (*urea and H<sub>2</sub>O*) in the catalytic converter and inject this material inside catalytic converter by using suitable injector

- Evaluation of performance for catalytic converter to reduce toxic emissions exhaust from internal combustion engines in vehicles.
- Studying about catalytic converter and comparing between the data sheet of catalytic converter and resulting data when doing the experimental project.

## 1.4 Project Goals and Objectives

The overall aim of the project is to reduce the emission of regular pollutants, carbon monoxide, hydrocarbons and nitrogen oxides by using improved catalytic converter device.

### 1.4.1 General Goals

This project rotates about many of goals aims:

- To develop catalytic converter for reducing emission by adding some materials such as urea and inject this material by using suitable injector that operation at especial condition.
- To build experimental setup for evaluation of catalytic converter.
- To do experiments to evaluation proportion emission exhaust from the internal combustion engine by using sensor and to measure inlet and outlet toxic gas by using gas analyzer .
- Towards reducing emission and regulated pollutants carbon monoxide, hydrocarbons and oxides of nitrogen.

## 1.4.2 Specific Objective

This project contains many specific objective, aims to:

- Studying catalytic converter and comparing between the data sheet of catalytic converter and resulting data when doing the experimental project.
- Building experimental setup of carbon monoxide (CO) sensor at the inlet and exit of the catalytic converter to measure the proportion of toxic gas.
- Reduce emission and regulated pollutants especially oxides of nitrogen by adding some materials such as (*urea*) in the catalytic converter and inject this material inside catalytic converter by using suitable injector.

## 1.5 Project Choice Justification

As a result of development and technology in the vehicles, it causes pollutants that effect on the human health and environmental so, many point is the most important justification:

- Increasing environmental problem, resulting from emission exist from internal combustion engine.
- It causes Greenhouse gas emissions from vehicle exhausts more than several times the permitted level according to *World Health Organization (WHO)* criteria, and this is a dangerous indicator of rising pollution and maybe lung disease and cancers of the Sense and harvested thousands of people annually.
- Increase the number of cars and dramatically, without attention to the harmful environmental impacts of the most important causes of the problem.
- Fuel specifications currently used especially diesel, which contains a high percentage of sulfur and carcinogenic effects with which to conflict with the requirements of international standards that protect the environment.

- In addition to the absence of the catalytic converter in the old cars and some modern and this contributes to increase air pollution especially that of the continuous monitoring of vehicles that emit smoke offense almost absent. And toxic elements have become a real threat to human health the dangerous gas pollution resulting from auto.

## **1.6 Project Implementation Plan**

In this project will be evaluating of performance for catalytic converter and limit of emission exhaust from internal combustion engine and will be the tasks, goals and objectives, in addition to the time table, thus when they are achieved, and then the project has accomplished that level.

### **1.6.1 Main Task and Actives**

The main tasks for the first semester include:

- Selecting the project .
- Planning and setting project concepts and goals.
- Established scientific background.
- Study the types of catalytic converter.
- Collect the data about the project from the library, boxes and internet.
- Write the data and format it.
- Write the reference of the project.
- Finally print it.

## 1.6.2 Time Table

The time table for the first semester is illustrated in *Table 1.1*.

*Table 1.1: The time table for 1<sup>st</sup> semester*

Objective	Week #															
	1	2	3	4	5	6	7	8	9	10	11	12	13	14	15	16
Selecting project title	■	■	■	■												
Planning and Setting Project Concepts and Goals					■	■	■									
Establishing Scientific Background							■	■	■	■	■	■	■			
Knowing the type of cat.con.										■	■	■	■	■		
collection the data about catalytic converter										■	■	■	■	■	■	
Writing Report										■	■	■	■	■	■	
Presentation																■

In the second semester, the following tasks were planned:

- Building system include engine and exhaust system.
- Studying about catalytic converter and comparing between the data that write on the catalytic converter and resulting data when doing the experimental project.
- Installation catalytic converter between exhaust manifold and muffler.
- Building experimental setup of carbon monoxide (CO) sensor at the inlet and exit of the catalytic converter to measure the proportion of toxic gas.
- Evaluation of performance for catalytic converter to reduce toxic emissions exhaust from internal combustion engines in vehicles.
- Develop a catalytic converter to reduce the proportion of toxic gases by adding some materials such as (*urea*) in the catalytic converter and inject this material inside catalytic converter by using suitable injector.



The time table for the second semester is illustrated in *Table 1.2*.

*Table (1.2): The time table for 2<sup>nd</sup> semester*

Objective	Week #															
	1	2	3	4	5	6	7	8	9	10	11	12	13	14	15	16
Design Catalytic Converter	█	█	█	█												
Installation of Cat. Converter and (CO)sensors					█	█	█									
Installation Injection Urea system							█	█	█	█	█	█	█			
Evaluation of Performance for cat. Converter										█	█	█	█	█		
Doing the Experiment of the Project												█	█	█	█	
Adjustment Data Project										█	█	█	█	█	█	
Write the resulting data										█	█	█	█	█	█	
Presentation																█

## 1.7 Preliminary Budget

Preliminary estimates are made for the project components as listed in table (1.3)

*Table (1.3): Preliminary budget*

NO.	Item	Estimated Cost (\$)
1	Catalytic Converter	200
2	Sensor CO "TGS"	200 X 2
3	Urea	50
4	Pump	25
5	Injector	30
6	Pressure regulator	20
7	Cost of printing and imaging	30
8	Other costs	250

# Chapter Two

## Internal Combustion Engine

- Introduction.
- Reactions that Occur in the Internal Combustion Engines.
- Products of the Reaction.
- Emission Control.

## 2.1 Introduction

The internal combustion engine is an engine in which the combustion of a fuel (generally fossil fuel) occurs with an oxidizer (usually air) in a combustion chamber. In an internal combustion engine the expansion of the high temperature and pressure gases, which are produced by the combustion, directly applies force to a movable component of the engine, such as the pistons or turbine blades and by moving it over a distance, generate useful mechanical energy.

The term internal combustion engine usually refers to an engine in which combustion is intermittent, such as the more familiar four-stroke and two-stroke piston engines, along with variants, such as the Wankel rotary engine.

A second class of internal combustion engines use continuous combustion: gas turbines, jet engines and most rocket engines, each of which are internal combustion engines on the same principle as previously described.

## 2.2 Reactions that Occur in the Internal Combustion Engines

### 2.2.1 Combustion Stoichiometry

If sufficient oxygen is available, a hydrocarbon fuel can be completely oxidized, the carbon is converted to carbon dioxide ( $\text{CO}_2$ ) and the hydrogen is converted to water ( $\text{H}_2\text{O}$ ).

The overall chemical equation for the complete combustion of one mole for *lambda*,  $\lambda = 1$

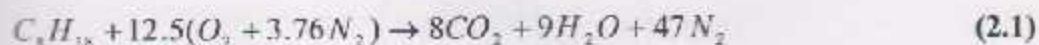

Where,

$\lambda$ : The ratio between amount of actual air and theoretical amount of air.

Air contains molecular nitrogen  $N_2$ , when the products are at low temperature the nitrogen is not significantly affected by the reaction, it is considered inert.

The complete reaction of a general hydrocarbon  $C_\alpha H_\beta$  with air is:

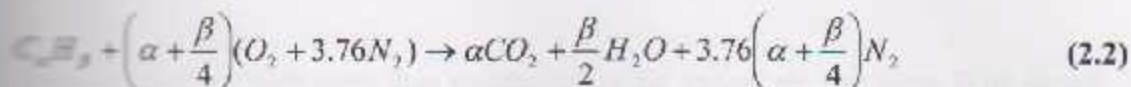

The above equation defines the stoichiometry proportions of fuel and air.

*Example:* For octane ( $C_8H_{18}$ ) at  $\alpha = 8$ ,  $\beta = 18$ .

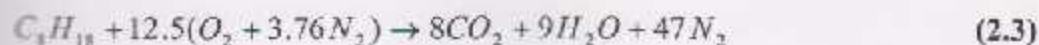

The Stoichiometry mass based air/fuel and fuel/air ratio is:

$$(A/F)_s = \frac{1}{(F/A)_s} = \frac{\left(\alpha + \frac{\beta}{4}\right)\bar{M}_{O_2} + 3.76\left(\alpha + \frac{\beta}{4}\right)\bar{M}_{N_2}}{\alpha\bar{M}_C + \beta\bar{M}_H} \quad (2.4)$$

Substituting the respective molecular weights and dividing top and bottom by  $\alpha$  one gets the following expression that only depends on the ratio of the number of hydrogen atoms to carbon atoms ( $\beta/\alpha$ ) in the fuel [2].

$$(A/F)_s = \frac{1}{(F/A)_s} = \frac{\left(1 + \frac{(\beta/\alpha)}{4}\right)(32 + 3.76 * 28)}{12 + (\beta/\alpha) * 1} \quad (2.5)$$

Note above equation only applies to Stoichiometry mixture.

$$\text{For octane (C}_8\text{H}_{18}), \quad \beta/\alpha = 2.25 \rightarrow (A/F) s = 15.1$$

$$\text{For methane (CH}_4\text{),} \quad \beta/\alpha = 4 \rightarrow (A/F) s = 17.2$$

### 2.2.2 Fuel Lean Mixture

Fuel-air mixtures with more than stoichiometry air, excess air, can burn. With excess air you get fuel lean combustion, the extra air appears in the products in unchanged form.

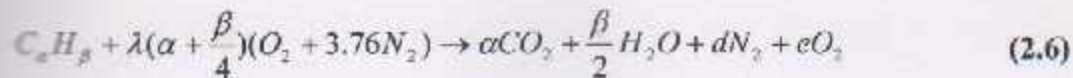

Where for fuel lean mixtures have excess air so for *lambda*  $\lambda > 1$

Above reaction equation has two unknowns ( $d$ ,  $e$ ) and we have two atom balance equations ( $O$ ,  $N$ ) so can solve for the unknowns.

### 2.2.3 Fuel Rich Mixture

Fuel-air mixtures with less than Stoichiometry air can also burn. With less than Stoichiometry air you get fuel rich combustion, there is insufficient oxygen to oxidize all the C and H in the fuel to  $\text{CO}_2$  and  $\text{H}_2\text{O}$ . Get incomplete combustion where carbon monoxide (CO) and molecular Hydrogen ( $\text{H}_2$ ) also appear in the products [2].

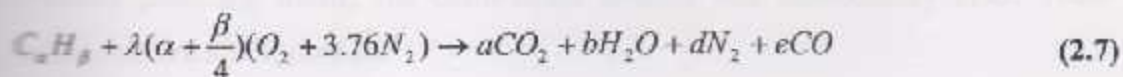

Where for fuel rich mixtures have insufficient air so for *lambda*  $\lambda < 1$

above reaction equation has four unknowns ( $a, b, d, e$ ) and we only have two atom balance equations ( $C, H$ ) so cannot solve for the unknowns unless additional information about the products is given.

*Example:* Consider a reaction of octane rich mixture with lambda equal 0.8.

The Stoichiometry reaction is:

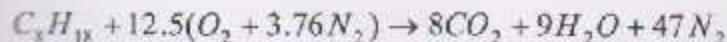

With lambda < 1

$$A/F = \text{mass air / mass fuel}$$

$$= 1441.4/114$$

$$= 12.64:1$$

## 2.3 Products of the Reaction

The products of the internal combustion engine are many type of gases, specially the nitrogen oxides (NO<sub>x</sub>), hydrocarbons (HC) and carbon monoxide (CO).

### 2.3.1 Nitrogen Oxides (NO<sub>x</sub>)

NO<sub>x</sub> include nitric oxide (NO) and nitrogen dioxide (NO<sub>2</sub>) and formed only at high temperatures and the reaction rate is relatively slow

In SI engines the dominant component of NO<sub>x</sub> is NO forms as a result of dissociation of molecular nitrogen and oxygen.

There are a number of possible reactions that form NO. All the reactions are probably occurring during the combustion process and immediately after. These include but are not limited to:



NO, in turn can further react to form NO<sub>2</sub> by various means including



### 2.3.2 Hydrocarbons

Hydrocarbon emissions result from the presence of unburned fuel in the engine exhaust

However, some of the exhaust hydrocarbons are not found in the fuel, but are hydrocarbons derived from the fuel whose structure was altered due to chemical reaction that did not go to completion.



### 2.3.2.1 Hydrocarbon Emission Sources

- **Crevice:** these are narrow regions in the combustion chamber into which crevices are located around the piston, head gasket, spark plug and valve seats and represent about 1 to 2% of the clearance volume.
- **Oil layers:** Since the piston ring is not 100% effective in preventing oil migration into the cylinder above the piston, oil layers exist within the combustion chamber
- **Deposits:** With continued use carbon deposits build up on the valves, cylinder and piston head. These deposits are porous with pore sizes smaller than the quenching distance so trapped fuel cannot burn.
- **Liquid fuel:** For some fuel injection systems there is a possibility that liquid fuel is introduced into the cylinder past an open intake valve. The less volatile fuel constituents may not vaporize (especially during engine warm-up) and be absorbed by the crevices or carbon deposits.
- **Flame quenching:** It has been shown that the flame does not burn completely to the internal surfaces, the flame extinguishes at a small but finite distance from the wall. Most of this gas eventually diffuses into the burned gas during expansion stroke [2].

### 2.3.3 Carbon Monoxide

Carbon monoxide appears in the exhaust of fuel rich running engines. For fuel rich mixtures there is insufficient oxygen to convert all the carbon in the fuel to carbon dioxide.

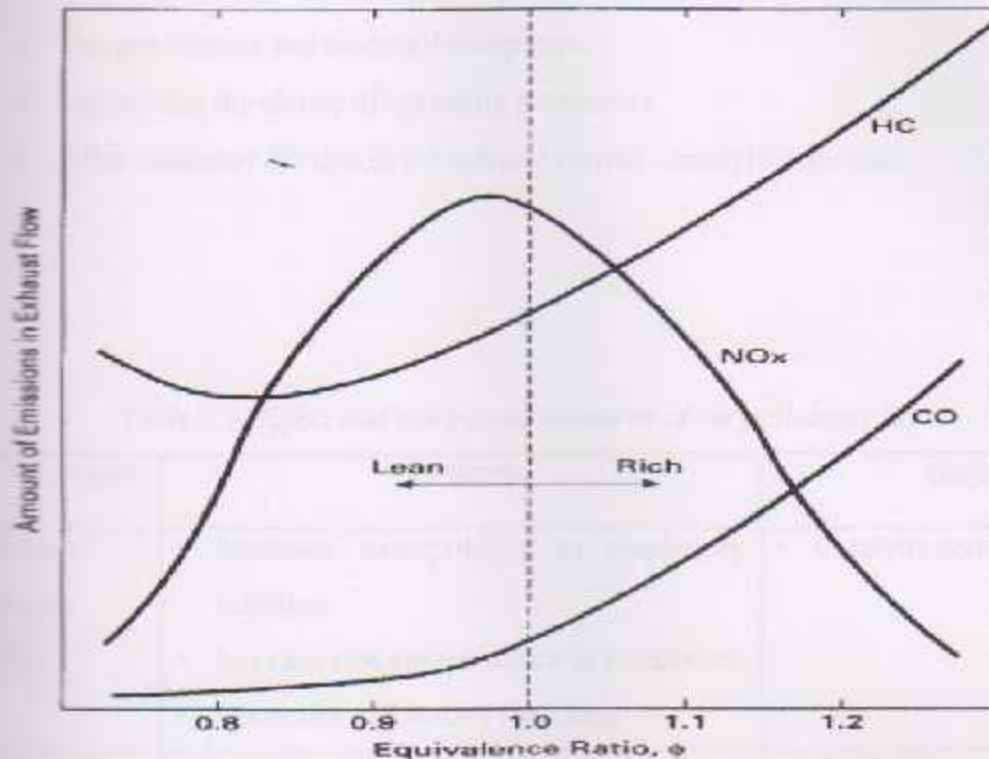

Figure (2.1): Amount of emissions in exhaust and equivalence ratio in general.

Emissions from an SI engine as a function of equivalence ratio. Fuel rich air-fuel ratio does not have enough oxygen to react with all the carbon and hydrogen. And both HC and CO emissions increase HC emissions also increase at very lean mixtures due to poor combustion and misfires. The generation of nitrogen oxide emission is function of the combustion temperature .Being greatest near Stoichiometry condition when temperatures are the highest .Peak NO<sub>x</sub> emissions occur at slightly lean condition, where the combustion temperature is high and there is an excess of oxygen to react with the nitrogen [2].

## 2.4 Emission Control

The current emission limits for HC, CO and NOx have been reduced to 4% and 10% of the uncontrolled pre-values, respectively.

Three basic methods used to control engine emissions:

- Oxygen sensors and on-board computers.
- Optimizing the choice of operating parameters
- After treatment devices in the exhaust system - catalytic converter

Table 2.1: Effect and mitigation measures of air pollutants [2]

POLLUTANT	EFFECTS	REMEDY
Oxides of nitrogen (NO <sub>x</sub> )	<ul style="list-style-type: none"> <li>• Increases susceptibility to respiratory infection</li> <li>• Increase airways resistance in asthmatics</li> <li>• Decreases pulmonary functions.</li> </ul>	<ul style="list-style-type: none"> <li>• Catalytic converter</li> </ul>
Ozone (O <sub>3</sub> )	<ul style="list-style-type: none"> <li>• Irritation of the eyes and nose</li> <li>• Damage the lining of the airways</li> <li>• Inflammatory reactions</li> </ul>	<ul style="list-style-type: none"> <li>• Catalytic converter</li> </ul>
Carbon monoxide (CO)	<ul style="list-style-type: none"> <li>• Hinders oxygen transport from blood tissues</li> <li>• Cardiovascular diseases</li> <li>• Neurobehavioral effects</li> </ul>	<ul style="list-style-type: none"> <li>• Catalytic converter</li> <li>• Emission standards set up</li> </ul>
Sulphur Dioxide (SO <sub>2</sub> )	<ul style="list-style-type: none"> <li>• Acid deposition</li> <li>• Respiratory problems</li> <li>• Disability and even death</li> </ul>	<ul style="list-style-type: none"> <li>• Reduction of sulphur content in diesel</li> </ul>

Particulate Matter (PM) and Unburnt Hydrocarbons (HC)	<ul style="list-style-type: none"> <li>• Lung damage</li> <li>• Diesel particles</li> <li>• Mutagenic</li> <li>• Carcinogenic</li> <li>• Degrade aesthetic and material usage through soiling</li> </ul>	<ul style="list-style-type: none"> <li>• Catalytic converter</li> <li>• Reduction of sulphur content in diesel</li> <li>• Emission Standards set up</li> </ul>
---	--	--

## Chapter Three

### Catalytic Converter

- Introduction
- Construction of the Converter Components
- Three-Stage Catalytic Converter
- Two-Stage Catalytic Converter
- Two-Stage Catalytic Converter
- Two-Stage Catalytic Converter
- Two-Stage Catalytic Converter
- Two-Stage Catalytic Converter
- Two-Stage Catalytic Converter
- Two-Stage Catalytic Converter
- Two-Stage Catalytic Converter

# Chapter Three

## Catalytic Converter

- Introduction
- Components of the Catalytic Converter
- Work of the Catalytic Converter
- Types of Catalytic Converter
- Basic Emission Control Systems
- Installation
- Converter Operation
- Causes of Catalytic Converter Plugging
- Causes of Catalyst Fouling
- Catalytic Converter Operating Efficiency

## 1.1 Introduction

The catalytic converter was invented by Eugene Houdry, a French mechanical engineer, when the results of early studies of smog in Los Angeles were published. Houdry became concerned about the role of automobile exhaust in air pollution and founded a special company, *Oxy-Catalyst*, to develop catalytic converters for gasoline engines. But until the extremely effective anti-knock agent tetra-ethyl lead was eliminated from most gasoline over environmental concerns, it would "poison" the converter by forming a coating on the catalyst's surface, effectively disabling it.

The catalytic converter was later on further developed by John J. Mooney and Carl D. Smith at the Engelhard Corporation, creating the first production catalytic converter in 1953.

A catalytic converter is a device used to reduce the toxicity of emissions from an internal combustion engine. Catalytic converters are still most commonly used in motor vehicle exhaust systems.

Catalytic converters are also used on generator sets, forklifts, mining equipment, trucks, buses, trains, and other engine-equipped machines. A catalytic converter provides an environment for a chemical where in toxic combustion by-products are converted to less-toxic substances.

Catalytic converters are one of the greatest emission add-ons ever to be installed on vehicles. By cleaning up the pollutants left over from combustion, they reduce tailpipe emissions of hydrocarbons (HC) and carbon monoxide (CO) to extremely low levels, when everything is operating normally. But sometimes things do not operate normally, and when that happens engine performance may suffer or the vehicle may fail an emissions test.

Driveability symptoms such as a drop in fuel economy, lack of high speed power, rough idle or stalling are classic symptoms of excessive backpressure due to a clogged converter.

Elevated HC and CO tailpipe emissions, on the other hand, are often symptoms of a fouled converter or a faulty air supply (bad or leaky air pump, diverter valve or pulse air system). A fouled converter may not cause any increase in backpressure, so other methods of checking the converter are required for this type of problem.

The important point to remember here is that converters don't just plug up or die for no good reason. There is usually an underlying cause which must also be diagnosed and corrected before the problem can be eliminated. Diagnosing a plugged or fouled catalytic converter is only half the fix. Replacing a bad catalytic converter will only temporarily restore things to normal because unless the underlying problem that caused the original converter to fail is identified and fixed, the replacement converter will likely suffer the same fate.

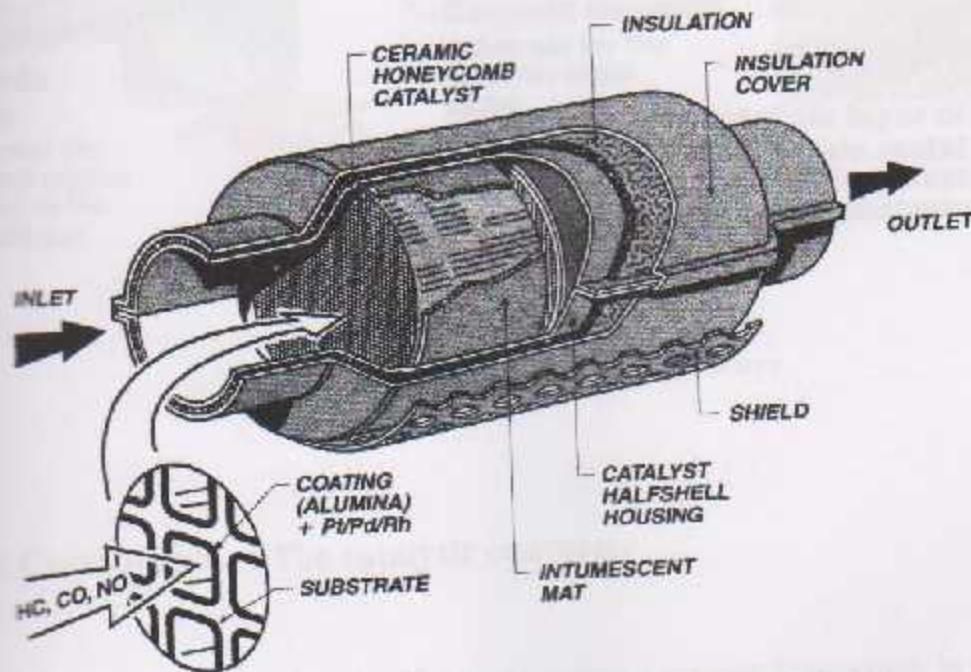

Figure (3.1) Catalytic Converters

Lead and sulfur in the exhaust gas severely inhibit the operation of a catalytic converter (poison)

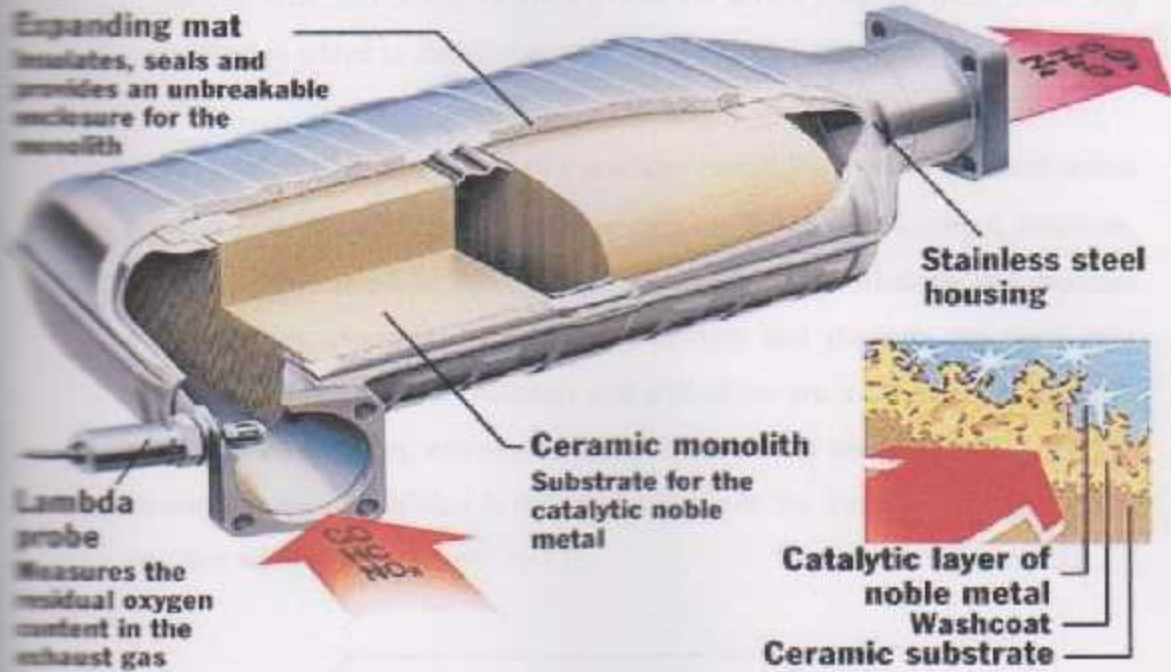

Figure (3.2) Modern Catalytic Converters

### 3.2 Components of The catalytic converter

1. The core or substrate. The core is often a ceramic honeycomb in modern catalytic converters, but stainless steel foil honeycombs are used, too. The honey-comb surface increases the amount of surface area available to support the catalyst, and therefore is often called a "catalyst support". The ceramic substrate was invented by Rodney Bagley, Irwin Lachman and Ronald Lewis at Corning Glass, for which they were inducted into the National Inventors Hall of Fame in 2002.



2. The washcoat. A washcoat is used to make converters more efficient, often as a mixture of silica and alumina. The washcoat, when added to the core, forms a rough, irregular surface, which has a far greater surface area than the flat core surfaces do, which then gives the converter core a larger surface area, and therefore more places for active precious metal sites. The catalyst is added to the washcoat (in suspension) before being applied to the core.
3. The catalyst itself is most often a precious metal. Platinum is the most active catalyst and is widely used. It is not suitable for all applications, however, because of unwanted additional reactions and/or cost. Palladium and rhodium are two other precious metals used. Platinum and rhodium are used as a reduction catalyst, while platinum and palladium are used as an oxidation catalyst. Cerium, iron, manganese and nickel are also used, although each has its own limitations. Nickel is not legal for use in the European Union (due to reaction with carbon monoxide) [3].

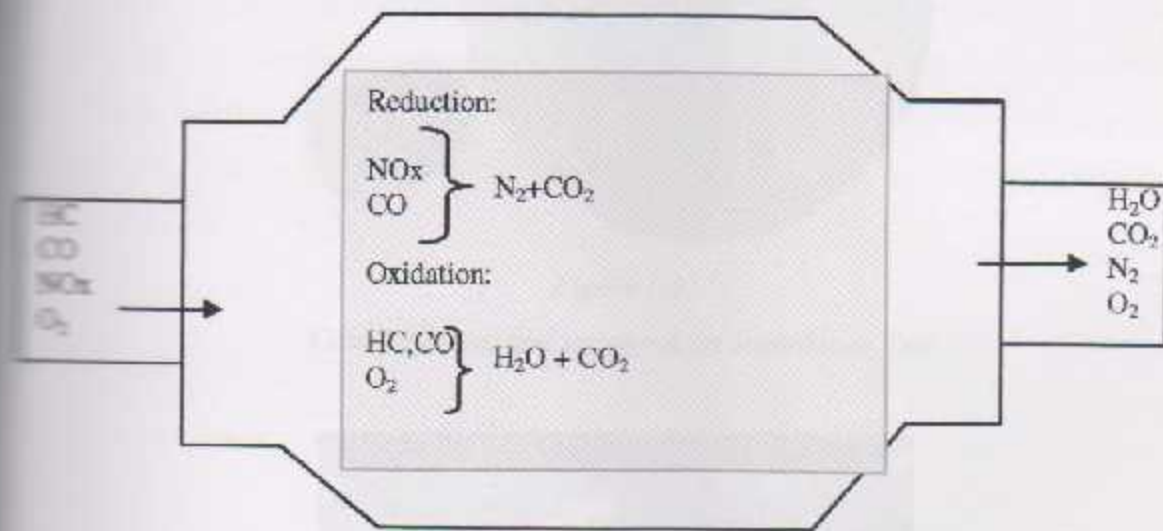
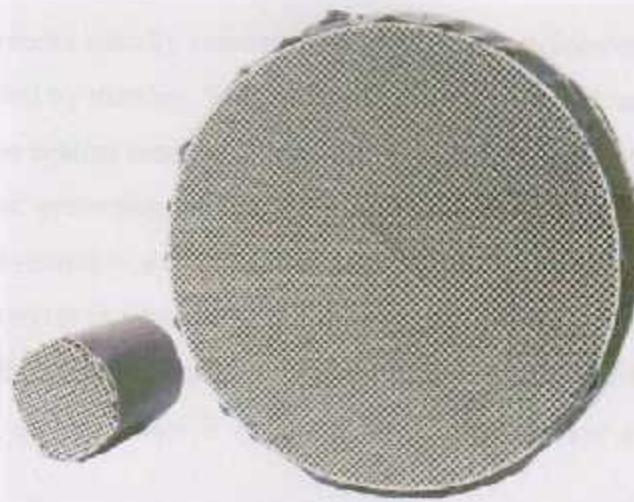

Figure (3.3)  
Oxidation and reduction process into catalytic converter.

### 3.3 Work of The catalytic converter

A catalytic converter is a metal box with chemical catalysts inside it that sits underneath your car. There's a pipe going into one end of the converter from the car engine and another pipe going out of the other end of the converter to the car's exhaust. The catalysts make chemical reactions happen that convert the molecules of pollution into simple, harmless gases. These are many safes to pass into the outside air [3].



*Figure (a)*

*Catalyst as cut and prepared for Impedance Test*



*Figure (b)*

*Metal-core converter*



*Figure (C)*

*Ceramic-core converter*

*Figure (3.3" a,b,c")*

The catalytic converter usually consists of a honeycomb structured ceramic monolith, which is surrounded by matting. The matting holds the monolith securely in place and provides a cushion against road shock and vibration. This is all encased in a steel shell to provide further protection. Another option is a steel monolith, which is more durable. The steel monolith we supply has a texture similar to cotton wool.

The catalytic converter is situated in the exhaust pipe, usually close to the manifold. This is because the catalyst needs to reach a certain temperature before it starts to operate properly, so the closer it is to the engine the quicker it reaches operating temperature.



*Figure (3.4)*

*CO, HC and NO enter the catalyst*

Carbon Monoxide (CO)

Hydrocarbons (HC)

Nitrous Oxide (NO)

*CO<sub>2</sub>, H<sub>2</sub>O and N leave the catalyst as fumes*

Carbon Dioxide (CO<sub>2</sub>)

Water (H<sub>2</sub>O) + (CO<sub>2</sub>)

Nitrogen (N)

The monolith is coated with platinum, palladium and rhodium. These substances cause a chemical reaction to take place as the exhaust fumes pass through the monolith. The carbon monoxide is converted to carbon dioxide, the hydrocarbons are converted into water and carbon dioxide, and nitrous oxide is converted into nitrogen.

### 3.4 Types of catalytic converter

There are many types of catalytic converter and the most important is:

#### 1 - Two-way Catalytic Converter

A two-way catalytic converter has two simultaneous tasks:

1. Oxidation of carbon monoxide to carbon dioxide:  
 $2CO + O_2 \rightarrow 2CO_2$
2. Oxidation of unburnt hydrocarbons (unburnt and partially-burnt fuel) to carbon dioxide and water:

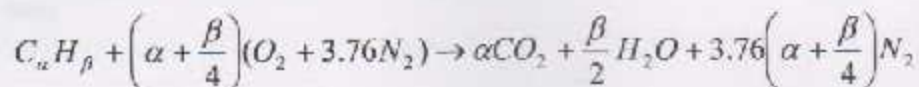

This type of catalytic converter is widely used on diesel engines to reduce hydrocarbon and carbon monoxide emissions.

When the two-way converter's inability to control NO<sub>x</sub> led to its supersession by three-way converters.

## 2-Three-way catalytic converter

Three-way catalytic converters have been used in vehicle emission control systems in North America and many other countries on road going vehicles. A three-way catalytic converter has three simultaneous tasks:

1. Reduction of nitrogen oxides to nitrogen and oxygen:  $2NO_x \rightarrow xO_2 + N_2$
2. Oxidation of carbon monoxide to carbon dioxide:  $2CO + O_2 \rightarrow 2CO_2$
3. Oxidation of un burnt hydrocarbons (HC) to carbon dioxide and water:

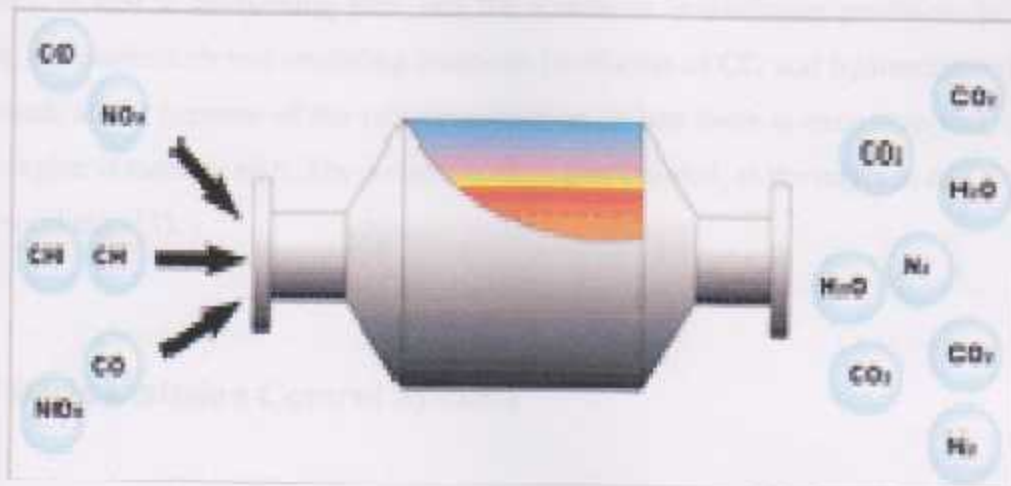
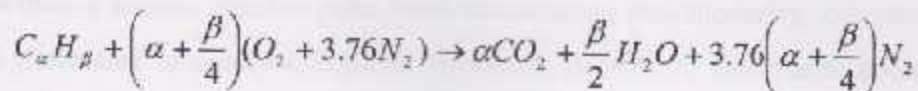

Figure (3.5)

CO, HC and NO enter the catalyst

Carbon Monoxide (CO)

Hydrocarbons (HC)

Nitrous Oxide (NO)

CO<sub>2</sub>, H<sub>2</sub>O and N leave the catalyst as fumes

Carbon Dioxide (CO<sub>2</sub>)

Water (H<sub>2</sub>O)+(CO<sub>2</sub>)

Nitrogen (N)

These three reactions occur most efficiently when the catalytic converter receives exhaust from an engine running slightly above the stoichiometric point. This is between 14.6 and 14.8 parts air to 1 part fuel, by weight for gasoline. The ratio for LPG, natural gas and ethanol fuels is slightly different, requiring modified fuel system settings when using those fuels. Generally, engines fitted with 3-way catalytic converters are equipped with a computerized closed-loop feedback fuel injection system employing one or more oxygen sensors, though early in the deployment of 3-way converters, carburetors equipped for feedback mixture control were used. While a 3-way catalyst can be used in an open-loop system,  $\text{NO}_x$  reduction efficiency is low, within a narrow fuel/air ratio band surrounding stoichiometry, conversion of all three pollutants is nearly complete. However, outside of that band, conversion efficiency falls off very rapidly. When there is more oxygen than required, then the system is said to be running lean, and the system is in oxidizing condition. In that case, the converter's two oxidizing reactions (oxidation of CO and hydrocarbons) are favored, at the expense of the reducing reaction. When there is excessive fuel, then the engine is running rich. The reduction of  $\text{NO}_x$  is favored, at the expense of CO and HC oxidation [3].

### **3.5 Basic Emission Control Systems**

When the first emission controls were first introduced back in the late 1960s, they were primarily "add-on" components that solved a particular emission need. When positive crankcase ventilation (PCV) became standard in 1968, the recycling of crankcase vapors eliminated blow by emissions as a major source of automotive pollution. When Evaporative Emission Control Systems were added in 1971, charcoal canisters and sealed fuel systems eliminated fuel vapors as another factor that contributed to air pollution. Exhaust gas recirculation (EGR) was added in 1973, which lowered harmful oxides of nitrogen ( $\text{NO}_x$ ) emissions. But the most significant add-on came in 1975 when the auto makers were required to install catalytic converters on all new cars.

The catalytic converter proved to be a real breakthrough in controlling emissions because it reduced both unburned hydrocarbons (HC), a primary factor in the formation of urban smog, and carbon monoxide (CO), the most dangerous pollutant because it can be deadly even in small concentrations. The converter slashed the levels of these two pollutants nearly 90%.

The early two-way converters (so-called because they eliminated the two pollutants HC and CO) acted like an afterburner to re burn the pollutants in the exhaust.

An air pump or an aspirator system provided the extra oxygen in the exhaust to get the job done. Two-way converters were used up until 1981 when three-way converters were introduced. Three-way converters also reduced  $\text{NO}_x$  concentrations in the exhaust, but required the addition of a computerized feedback fuel control system to do so.

Unlike the earlier two-way converters that could perform their job relatively efficiently with a lean fuel mixture, the catalyst inside a three-way converter that reduces  $\text{NO}_x$  requires a rich fuel mixture. But a rich fuel mixture increases CO levels in the exhaust. So to reduce all three pollutants (HC, CO and  $\text{NO}_x$ ), a three-way converter requires a fuel mixture that constantly changes or flip flops back and forth from rich to lean. This, in turn, requires feedback carburetion or electronic fuel injection, plus an oxygen sensor in the exhaust to keep tabs on what is happening with the fuel mixture.

Like the earlier two-way converters, three-way converters also require extra oxygen from an air pump or aspirator system, and some.

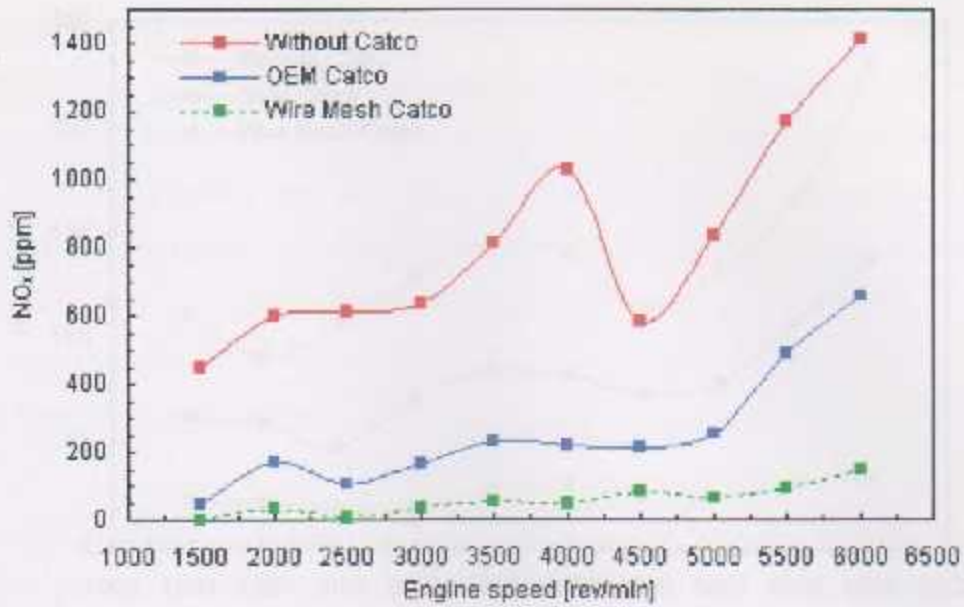

Figure (3.6)

*NOx emission versus engine speed (with and without catalytic converter)*

### Original equipment manufacturer(OEM)

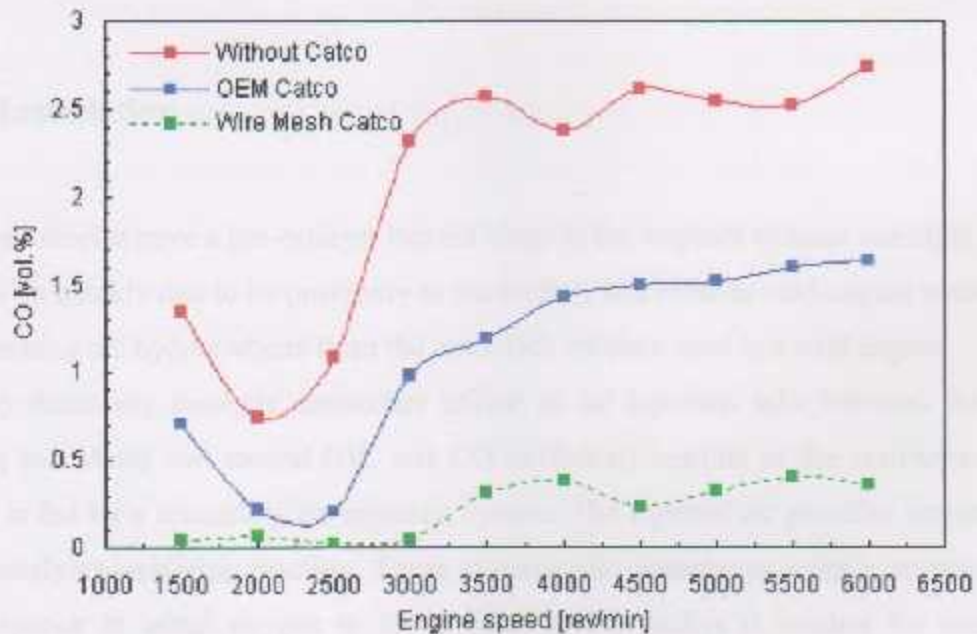

Figure (3.7)

*CO emission versus engine speed (with and without catalytic converter)*



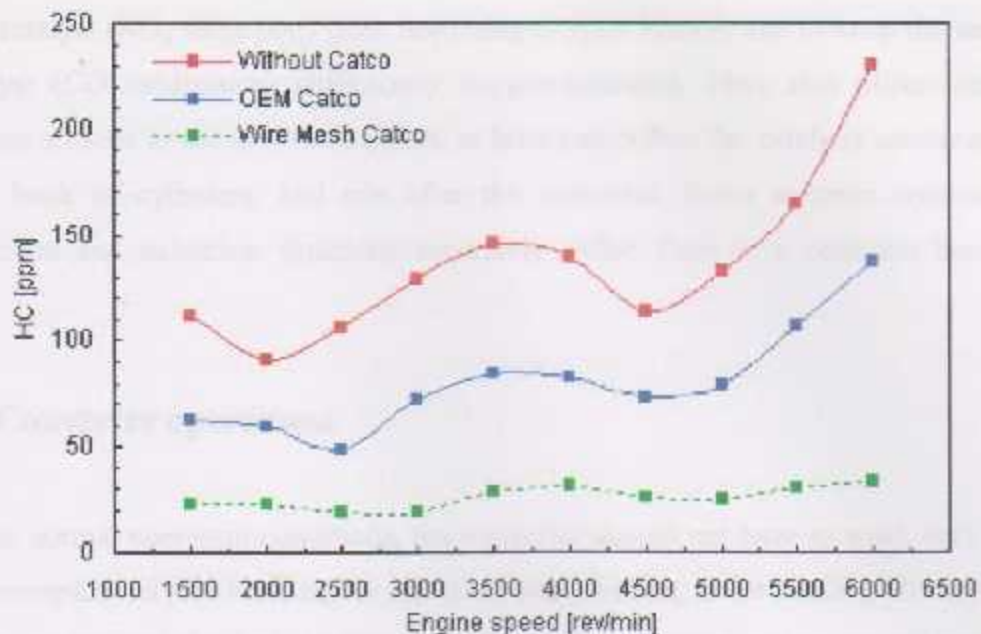

Figure (3.8)

*HC emission versus engine speed (with and without catalytic converter)*

three-way plus oxygen" converters are designed so air is routed right to the converter itself for more efficient operation [3].

### 3.6 Installation

Many vehicles have a pre-catalyst located close to the engine's exhaust manifold. This heats up quickly due to its proximity to the engine, and reduces cold-engine emissions by burning off hydrocarbons from the extra-rich mixture used in a cold engine.

Many three-way catalytic converters utilize an air injection tube between the first ( $\text{NO}_x$  reduction) and second (HC and CO oxidation) biscuits of the converter. This tube is fed by a secondary air injection system. The injected air provides oxygen for the catalyst's oxidizing reaction. These systems also sometimes include an upstream air injector to admit oxygen to the exhaust system before it reaches the catalytic converter. This precleans the extra-rich exhaust from a cold engine, and helps bring the catalytic converter quickly up to operating temperature.

Some newer systems do not employ air injection. Instead, they provide a constantly varying mixture that quickly and continually cycles between lean and rich to keep the

first catalyst (NO<sub>x</sub> reduction) from becoming oxygen loaded, and to keep the second catalyst (CO oxidization) sufficiently oxygen-saturated. They also utilize several oxygen sensors to monitor the exhaust, at least one before the catalytic converter for each bank of cylinders, and one after the converter. Some systems contain the reduction and oxidation functions separately rather than in a common housing.

### **3.7 Converter operations**

Under normal operating conditions, the converter should not have to work very hard to accomplish its job. If an engine has good compression, is not sucking oil down the valve guides, and the fuel, ignition and engine management system are all working properly, there should be relatively little HC and CO in the exhaust for the converter to burn (a few tenths of a percent CO and less than 150 ppm of HC when the engine is warm). In many late-model engines with multipoint fuel injection, combustion is so clean that the converter has little to do and the difference between the inlet and outlet temperature may only be 30 degrees F at 2,500 rpm which is a lot less than the old rule of thumb that says a good converter should show at least a 100 degree F difference fore and aft at cruise. At idle, the converter in many late-model vehicles may cool off so much that there's almost no measurable difference in fore and aft temperatures. So checking exhaust temperatures fore and aft of the converter at idle and 2,500 rpm may not be the most accurate way to determine if the converter is working or not.

One thing temperature measurements, is if the converter is working too hard. An infrared non contact pyrometer or a temperature probe if the converter is running unusually or dangerously hot. If the converter outlet temperature is 200 or more degrees higher than the inlet temperature, it means the engine is running rich and there's a lot of CO in the exhaust that needs to be burned. A rich fuel mixture will often produce a "rotten egg" odor in the exhaust (the smell is hydrogen sulfide). Underlying problems may include an engine management system that is not going into closed loop (check the coolant and oxygen sensors, or for a thermostat stick in the open position), plugged PCV valve, or excessive fuel pressure (bad fuel regulator). High CO levels in the exhaust can also be caused by an inoperative air pump system.

If the outlet temperature is a lot hotter (more than 500 degrees F) than the inlet temperature, it indicates unburned fuel in the exhaust. The most likely cause would be ignition misfire (fouled spark plug, shorted or open plug wire, cracked distributor cap, arcing rotor or weak coil), or a compression leak (burned exhaust valve). But other causes may include lean misfire (check for vacuum leaks, leaky EGR valve, low fuel pressure or dirty injectors). A single misfiring spark plug can cause an increase in HC emissions of 2,500 or more parts per million, which can push the converter's operating temperature well above its normal range [3].

### **3. 8 Causes of catalytic converter plugging**

Prolonged overheating or short term severe overheating are the leading causes of catalytic converter plugging. The underlying cause here is often fouled or misfiring spark plugs, or a burned exhaust valve that leaks compression and allows unburned fuel to pass through the combustion chamber into the exhaust.

The average light off temperature at which the catalytic converter begins to function ranges from 400 to 600 degrees F. The normal operating temperature can range up to 1,200 to 1,600 degrees F. But as the amount of pollutants in the exhaust goes up, so does the converter's operating temperature. If the temperature gets up around 2,000 degrees F or higher, several things happen. The aluminum oxide honeycomb begins to degrade and weaken. The platinum and palladium coating on the honeycomb also starts to melt and sink into the ceramic substrate reducing its effect on the exhaust. This accelerates the aging process and causes the converter to lose efficiency.

If the overheating condition persists for a long period of time, or if the temperature soars high enough, the honeycomb itself may breakdown and melts forming a partial or complete obstruction and causing a sharp rise in backpressure. A complete blockage will cause the engine to stall shortly after starting, and will not allow exhaust to exit the engine.

Some degree of restriction inside the converter honeycomb can also be caused by accumulated deposits: phosphorus from oil burning and/or carbon from oil burning, a rich fuel mixture or frequent short trip driving where the converter rarely reaches light-off temperature). Physical damage to the honeycomb as a result of road hazards

or severe jolts may cause the relatively brittle ceramic honeycomb to break or crumble inside the converter shell. A rattling noise when you shake or thump the converter would tell you there's loose debris inside. An undamaged monolith converter should make no noise.

### **3.9 Causes of catalyst fouling**

To clean the exhaust, the catalyst inside the converter must be exposed to the hot exhaust gases. Lead, phosphorous and silicone can contaminate the catalyst and prevent it from working its magic. Lead used to be the most common contaminant, but is no more since it was eliminated from gasoline. Phosphorus is still a threat, and comes from motor oil. So if an engine is burning oil because of worn valve guides or rings, phosphorus will shorten the life of the converter. Blue smoke in the exhaust and an emissions failure are pretty good clues that the converter has been fouled with phosphorus.

The new "SJ" rated motor oils contain less phosphorus than earlier SH rated oils. The difference isn't much (about 20% less compared to SH oils), but over time the lower level of phosphorus reduces contamination to extend the life of the converter.

Silicone can find its way into the exhaust if the engine develops an internal coolant leak through a crack in a combustion chamber or a head gasket. Silicone will ruin the oxygen sensor as well as the catalytic converter, so chances are if the converter has been fouled the O<sub>2</sub> sensor will also need to be replaced. White smoke in the exhaust is a clue that there's an internal coolant leak.

### **3.10 Catalytic converter operating efficiency**

If a converter is not plugged and passes exhaust normally, and there are no other engine performance problems (fuel, ignition and compression all OK, and the computer going into closed loop), but HC and CO levels in the exhaust are higher than they should be, the converter may be fouled. Most original equipment converters

are designed for a service life of well beyond 100,000 miles, so if the converter has failed at low mileage contamination may be the culprit.

Checking converter operating efficiency can be done several ways. One "low tech" method is to make the fuel mixture momentarily rich by disconnecting the MAP sensor, or by creating excess HC in the exhaust by disconnecting and grounding a plug wire. Either condition should make the converter's operating temperature rise sharply, with the outlet temperature rising several hundred degrees over the inlet temperature. No change in temperature would tell you the catalyst is fouled and nothing is happening. Do not run this test for more than about two minutes because there's a risk of overheating and damaging what might be a good converter. Also, disconnecting the MAP sensor will likely set a trouble code, and on OBDII-equipped vehicles pulling a plug wire may set a misfire code.

The better approach is to read the composition of the exhaust gases with a 4- or 5-gas exhaust analyzer. Checking emission readings at the tailpipe will tell you whether or not they are within normal ranges and help you diagnose the cause if emissions are high. Doing a "cold start" emissions check when the engine is first started will tell you if there are any engine problems that need attention. A cold start, in this situation, is when the converter has cooled down for at least 20 minutes. It will take a couple of minutes for the converter to warm up to light off temperature, so during this time you have a relatively clear window of what's coming out of the engine. When the converter reaches operating temperature, there should be a measurable drop in HC and CO readings (the amount will depend on how dirty the baseline readings were). No change in readings would indicate a dead converter.

Another test is to create a momentary rich condition or a misfire (as described earlier) to see if the converter can clean it up. As the converter starts to react to the excess pollutants, its operating temperature should go up as the tailpipe emission readings come down.

Catalytic converter is a device used to reduce the toxicity of emissions from an internal combustion engine. It is a stainless steel box mounted in the exhaust system. Inside is a catalyst on a ceramic or metallic support protected from vibration and shock by a resilient ceramic or metallic 'mat'. The catalysts are combinations of platinum, palladium and rhodium.

# Chapter Four

## Sensor Concept and Types

- Introduction
- Sensor Concept
- Oxygen Sensors
- How an Oxygen Sensor Works
- Carbon Monoxide Sensor
- Carbon Monoxide (TGS) Sensor

## 4.1 Introduction

As the demand for automotive electronic systems grows, so does the need for accurate and reliable sensor components that provide data for these systems. Passengers today are benefiting from comprehensive safety packages and a host of other convenient and practical features that all rely on sensor technology.

Electronic sensors ensure that new vehicles are the safest cars on the road. Some examples of sensor technology include. The number of sensors used in automobiles has risen dramatically in the last decade. Current vehicles can contain 50-100 of them and this number is continually growing. The integration of these sensors allows vehicles to listen and react to the environment and provides the driver with countless benefits. The advent of sensor-driven technology has created a pressing need for new standards to provide for interoperability, compatibility and interchangeability [4]. Therefore, we will offer some of the sensors on the air streams entering into the combustion chamber and exit of air from the exhaust stream in the car.

## 4.2 Sensor Concept

An electronic device used to measure a physical quantity such as temperature, pressure or loudness and convert it into an electronic signal of some kind (e.g. a voltage). Sensors are normally components of some larger electronic system such as a computer control and/or measurement system [5].

Analog sensors most often produce a voltage proportional to the measured quantity. The signal must be converted to digital form with an ADC before the CPU can process it.

### 4.3 Oxygen Sensors

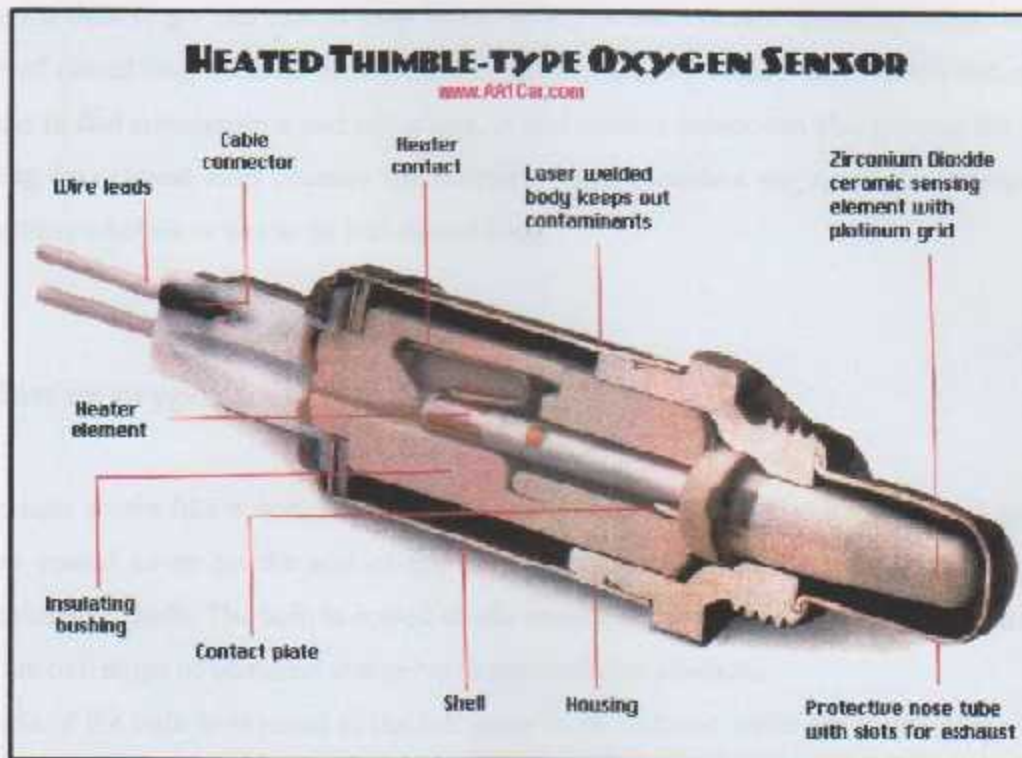

Figure (4.1)  
Oxygen Sensors

The computer uses the oxygen sensor input to regulate the fuel mixture, which is referred to as the fuel "feedback control loop." The computer takes its cues from the  $O_2$  sensor and responds by changing the fuel mixture. This produces a corresponding change in the  $O_2$  sensor reading. This is referred to as "closed loop" operation because the computer is using the  $O_2$  sensor's input to regulate the fuel mixture. The result is a constant flip-flop back and forth from rich to lean which allows the catalytic converter to operate at peak efficiency while keeping the average overall fuel mixture in proper balance to minimize emissions. It is a complicated setup but it works.



When no signal is received from the  $O_2$  sensor, as is the case when a cold engine is first started (or the  $O_2$  sensor fails), the computer orders a fixed (unchanging) rich fuel mixture. This is referred to as "open loop" operation because no input is used from the  $O_2$  sensor to regulate the fuel mixture.

If the engine fails to go into closed loop when the  $O_2$  sensor reaches operating temperature, or drops out of closed loop because the  $O_2$  sensor signal is lost, the engine will run too rich causing an increase in fuel consumption and emissions. A bad coolant sensor can also prevent the system from going into closed loop because the computer also considers engine coolant temperature when deciding whether or not to go into closed loop.

### 4.3.1 How an oxygen sensor works

The  $O_2$  sensor works like a miniature generator and produces its own voltage when it gets hot. Inside the vented cover on the end of the sensor that screws into the exhaust manifold is a zirconium ceramic bulb. The bulb is coated on the outside with a porous layer of platinum. Inside the bulb are two strips of platinum that serve as electrodes or contacts.

The outside of the bulb is exposed to the hot gases in the exhaust while the inside of the bulb is vented internally through the sensor body to the outside atmosphere. Older style oxygen sensors actually have a small hole in the body shell so air can enter the sensor, but newer style  $O_2$  sensors "breathe" through their wire connectors and have no vent hole. It is hard to believe, but the tiny amount of space between the insulation and wire provides enough room for air to seep into the sensor (for this reason, grease should never be used on  $O_2$  sensor connectors because it can block the flow of air). Venting the sensor through the wires rather than with a hole in the body reduces the risk of dirt or water contamination that could foul the sensor from the inside and cause it to fail [5].

The difference in oxygen levels between the exhaust and outside air within the sensor causes voltage to flow through the ceramic bulb. The greater the difference, the higher the voltage reading.

An oxygen sensor will typically generate up to about 0.9 volts when the fuel mixture is rich and there is little unburned oxygen in the exhaust. When the mixture is lean, the sensor output

voltage will drop down to about 0.2 volts or less. When the air/fuel mixture is balanced or at the equilibrium point of about 14.7 to 1, the sensor will read around .45 volts.

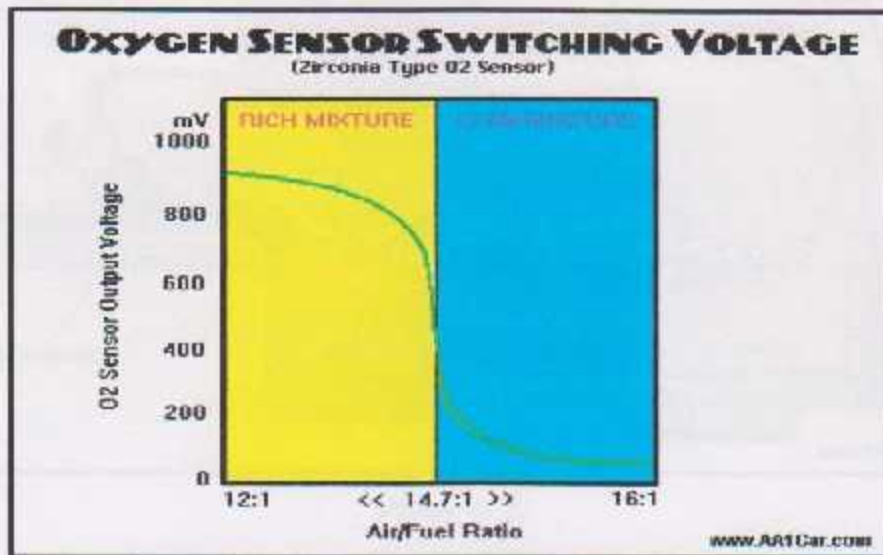

Figure (4.2)

*Oxygen sensor switching voltage*

When the computer receives a rich signal (high voltage) from the O<sub>2</sub> sensor, it leans the fuel mixture to reduce the sensor's feedback voltage. When the O<sub>2</sub> sensor reading goes lean (low voltage), the computer reverses again making the fuel mixture go rich. This constant flip-flopping back and forth of the fuel mixture occurs with different speeds depending on the fuel system. The transition rate is slowest on engines with feedback carburetors, typically once per second at 2500 rpm. Engines with throttle body injection are somewhat faster (2 to 3 times per second at 2500 rpm), while engines with multi port injection are the fastest (5 to 7 times per second at 2500 rpm).

The oxygen sensor must be hot (about 600 degrees or higher) before it will start to generate a voltage signal, so many oxygen sensors have a small heating element inside to help them reach operating temperature more quickly. The heating element

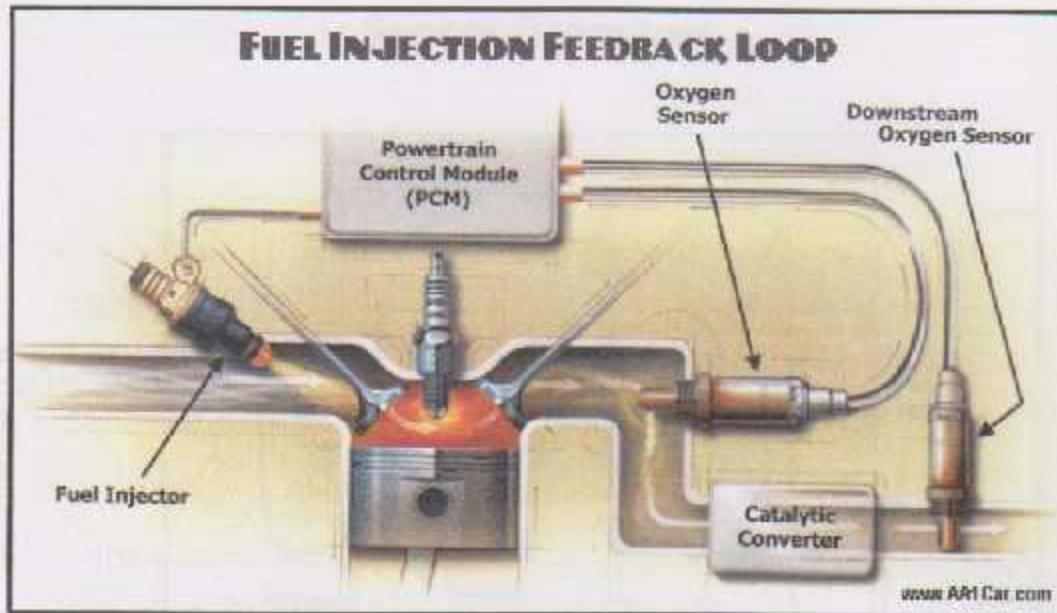

Figure (4.3)  
Feedback loop for lambda sensor

#### 4.4 Carbon Monoxide Sensor



Figure (4.4)  
CO sensor

## Sensor Response

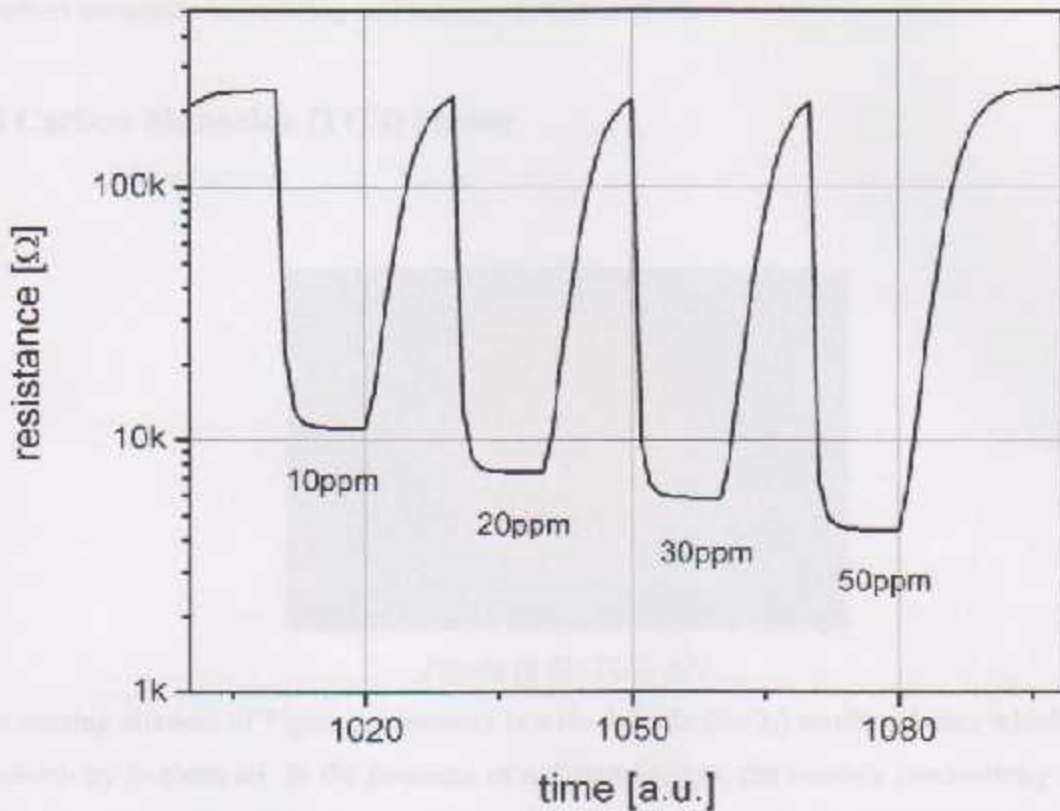

Figure (4.5): Sensor Response

### Key Benefits

- High sensitivity to CO (0.5 to 500 ppm).
- Low power consumption.
- Long lifetime.
- Small size for convenient installation.
- Long term stability.

## Typical Applications

- Carbon monoxide monitoring and leakage detection gases

## 4.5 Carbon Monoxide (TGS) Sensor



*Figure (4.6): TGS- 822*

The sensing element of Figaro gas sensors is a tin dioxide ( $\text{SnO}_2$ ) semiconductor which has low conductivity in clean air. In the presence of a detectable gas, the sensor's conductivity increases depending on the gas concentration in the air. A simple electrical circuit can convert the change in conductivity to an output signal which corresponds to the gas concentration.

The TGS 822 has high sensitivity to the vapors of organic solvents as well as other volatile vapors. It also has sensitivity to a variety of combustible gases such as carbon monoxide, making it a good general purpose sensor. Also available with a ceramic base which is a highly resistant to severe environment as high as  $200^\circ\text{C}$  (model# TGS 822).

The figure below represents typical sensitivity characteristics; all data having been gathered at standard test conditions (see reverse side of this sheet). The Y-axis is indicated as sensor resistance ratio ( $R_s/R_o$ ) which is defined as follows:

$R_s$  = Sensor resistance of displayed gases at various concentrations

$R_o$  = Sensor resistance in 300ppm ethanol

### 4.5.1 Sensitivity Characteristics

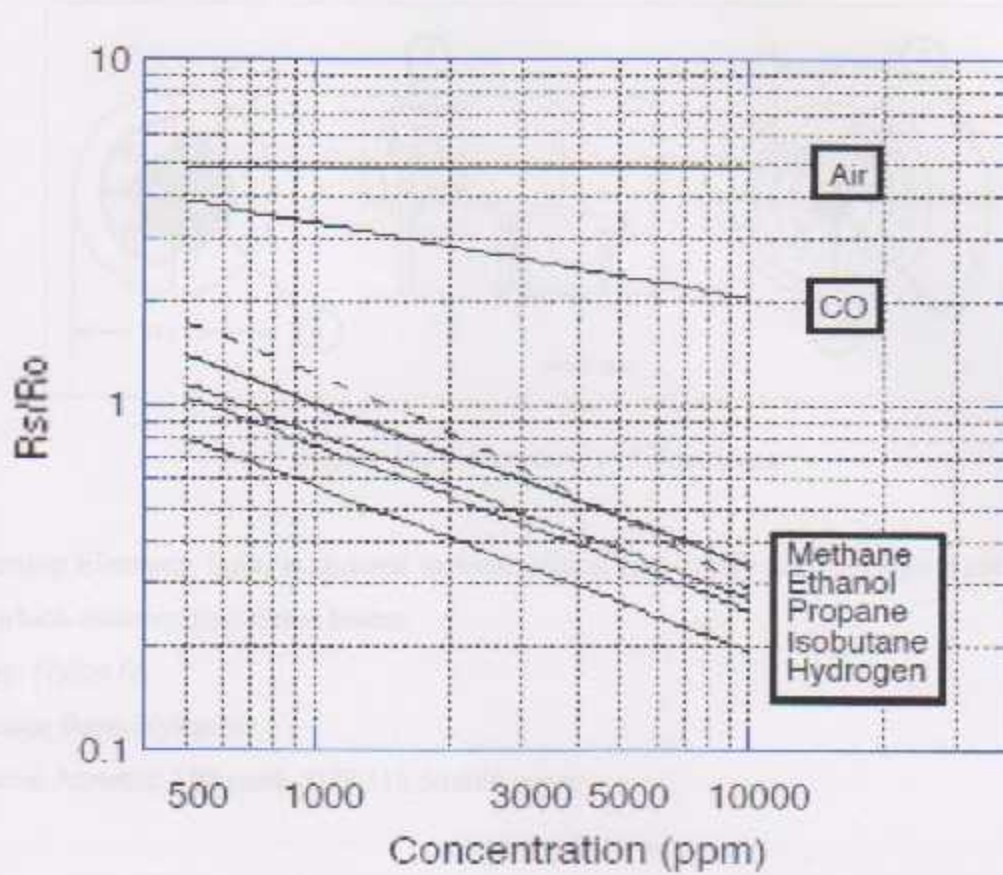

Figure (4.7): Sensitivity Characteristics

### 4.5.2 Structure and Dimension

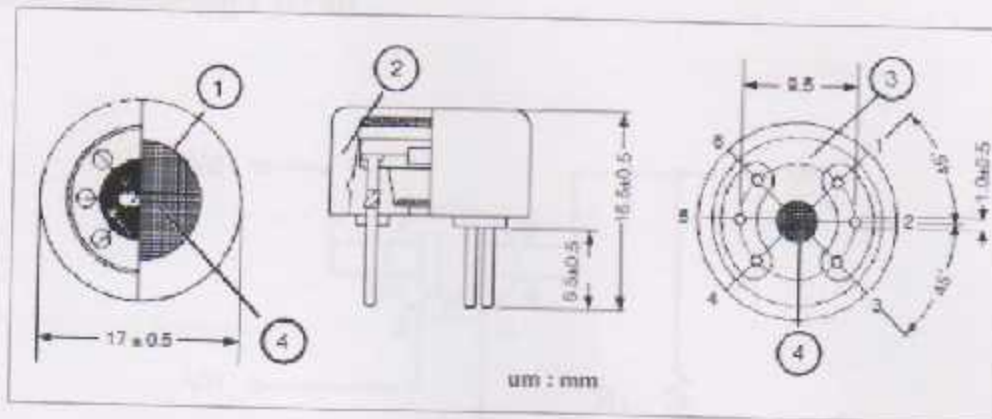

Figure (4.8): Structure and Dimension

- 1 -Sensing Element:  $\text{SnO}_2$  is sintered to form a thick film on the surface of an alumina ceramic tube which contains an internal heater.
- 2- Cap: Nylon 66
- 3- Sensor Base: Nylon 66
- 4- Flame Arrestor: 100 mcsh SUS 316 double gauze

### 4.4.3 Pin Connection and Basic Measuring Circuit

The numbers shown around the sensor symbol in the circuit diagram at the right correspond with the pin numbers shown in the sensor's structure drawing (above). When the sensor is connected as shown in the basic circuit, output across the Load Resistor (VRL) increases as the sensor's resistance ( $R_s$ ) decreases, depending on gas concentration sensor.

#### 4.5.4 Basic Measuring Circuit

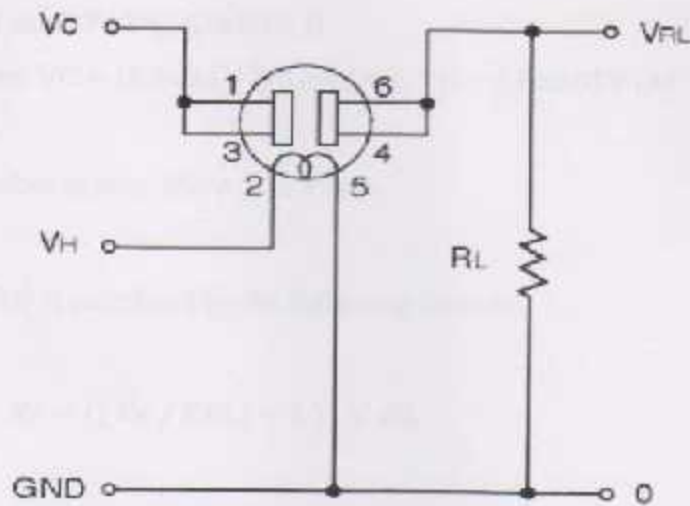

Figure (4.9): simple circuit sensor

#### 4.5.5 Standard Circuit Conditions

Table (4.1): Standard Circuit Conditions

Item	Symbol	Rated Values	Remarks
Heater Voltage	$V_H$	$5.0 \pm 0.2V$	AC or DC
Circuit Voltage	$V_C$	Max. 24V	DC only $P_S \leq 15mW$
Load Resistance	$R_L$	Variable	0.45k $\Omega$ min.



#### 4.5.6 Standard Test Conditions

TGS 813 complies with the above electrical characteristics when the sensor is tested in standard conditions as specified below:

Test Gas Conditions:  $20^{\circ}\pm 2^{\circ}\text{C}$ ,  $65\pm 5\%\text{R.H}$

Circuit Conditions:  $V_C = 10.0\pm 0.1\text{V}$  (AC or DC),  $V_H = 5.0\pm 0.05\text{V}$  (AC or DC),

$R_L = 4.0\text{k}\Omega\pm 1\%$

Preheating period before testing: More than 7 days

Sensor Resistance ( $R_s$ ) is calculated by the following formula:

$$R_s = ((V_c / V_{RL}) - 1) \times R_L \quad (4.1)$$

Power dissipation across sensor electrodes ( $P_s$ ) is calculated by the following formula:

$$P_s = \frac{V_c^2 \times R_s}{(R_s + R_L)^2} \quad (4.2)$$

RPM	CO		temp( $^{\circ}\text{C}$ )
	before (V) cat.con.	after (V) cat.con.	
750	9.30	1.33	56.00
1000	10.20	1.28	76.00
1500	10.57	1.09	92.00
2000	11.47	0.93	117.00
2500	10.90	0.87	143.00
3000	10.30	0.85	151.00
3500	10.20	1.10	197.00

*Table (4.2): Voltage signal out from TGS at different condition.*

Table (4.3): values of RS & PS at different condition.

RPM	RS		PS		RL(KΩ)	VC(V)
	before	after	before	after		
750	0.15	6.36	60.75	19.74	0.45	12
1000	0.18	8.38	64.75	15.49	0.45	12
1500	0.14	10.01	56.87	13.18	0.45	12
2000	0.05	11.90	27.02	11.23	0.45	12
2500	0.10	12.79	47.88	10.50	0.45	12
3000	0.17	13.12	62.83	10.26	0.45	12
3500	0.18	9.91	64.75	13.30	0.45	12

## Urea Injection System

- Introduction
- Urea Injection and Application
- Urea Injection System of Class (1000)cc
- Fuel and Air
- Urea Injection System
- Urea Injection System
- Urea Injection System



## 5.1 Background

Exhaust of NO<sub>x</sub> and particulate matter (PM) are of primary concern for health and global climate change. Heavy-duty engines, which produce high torque and power, are also the primary source of NO<sub>x</sub> and PM emissions. Higher fuel conversion and lower emissions of CO, HC, and CH<sub>4</sub> are

# Chapter Five

## Urea Injection System

- Background
- Urea Structure and Application
- NO<sub>x</sub> Optimizer Injection of Urea CO(NH<sub>2</sub>)<sub>2</sub>
- Features and Benefits
- NO<sub>x</sub> Reduction Reactions
- Urea Injection Requirements
- Solution Experiments

## 5.1 Background

Emissions of NO<sub>x</sub> and particulate matter (PM) are of primary concern for both diesel and gasoline vehicles to meet future emissions standards. Diesel vehicles have significant advantages over their gasoline counterparts including a more efficient engine, higher fuel economy, and lower emissions of HC, CO, and CO<sub>2</sub>.

Control of NO<sub>x</sub> in the vehicle is not a trivial task due to the high oxygen content of the exhaust gas. Such high oxygen fuel systems are typically referred to as lean burn systems. In such lean burn systems, NO<sub>x</sub> control is more difficult because of the high O<sub>2</sub> concentration in the exhaust, making conventional three-way catalysts ineffective. The available technologies for NO<sub>x</sub> reduction in lean environments include *Selective Catalytic Reduction (SCR)*, in which NO<sub>x</sub> is continuously removed through active injection of a reduction over a catalyst and Lean NO<sub>x</sub> Traps (LNT), which are materials that adsorb NO<sub>x</sub> under lean conditions and must be periodically regenerated by running under rich conditions. Technologies utilizing an ammonia based reduction, such as aqueous urea, have shown potential in achieving high NO<sub>x</sub> conversion with minimal fuel economy penalty.

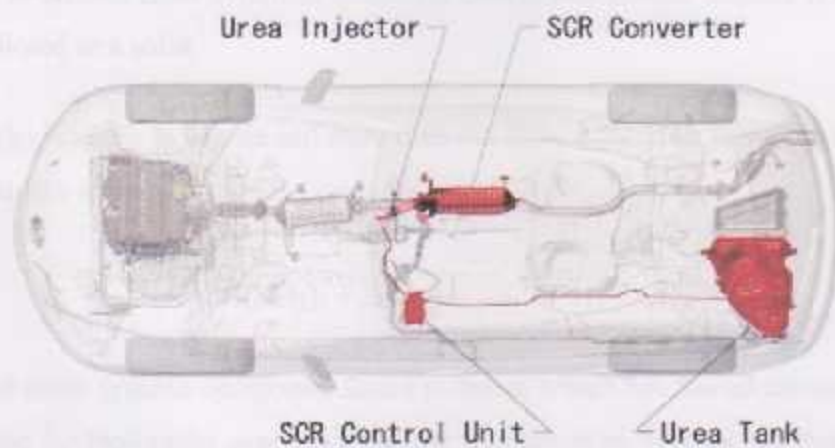

Figure (5.1) previous application of urea injection in diesel vehicles.

Selective Catalytic Reduction (SCR) with ammonia as the reduction has been used extensively for stationary source NO<sub>x</sub> control. The high selectivity of ammonia for reaction with NO<sub>x</sub> in high O<sub>2</sub> environments makes SCR attractive for use on diesel more than on gasoline vehicles. Compared to ammonia, aqueous urea is much easier for use onboard a vehicle. Although such SCR catalysts show great potential for NO<sub>x</sub> control, utilization of such catalysts are adversely affected by the presence of hydrocarbons in a vehicle exhaust. Specifically, hydrocarbons are known to poison most SCR catalysts[7].

## 5.2 Urea structure and Application

Urea CO(NH<sub>2</sub>)<sub>2</sub>, is an organic chemical compound which essentially is the waste produced when the body metabolizes protein. It is a compound not only produced by humans but also by many other mammals, as well as amphibians and some fish. Urea was the first natural compound to be synthesized artificially using inorganic compounds a scientific breakthrough.

Synthetic urea is created from synthetic ammonia (NH<sub>3</sub>) and carbon dioxide (CO<sub>2</sub>) and can be produced as a liquid or a solid.

Urea (CO(NH<sub>2</sub>)<sub>2</sub>) is easier to handle and store than the more dangerous ammonia (NH<sub>3</sub>). In the process it reacts like ammonia:

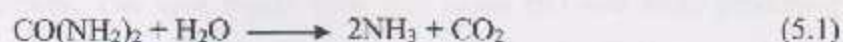

Urea is also the same organic compound found in urine, which has forced drivers (at least most drivers) to pause for bio-breaks ever since the car was invented. It turns out that urea, which is being sold under the more marketable name "diesel exhaust fluid," is also a chemically efficient way to reduce nitrogen oxide emissions[8]

In the fig (5.2) explain the main idea of work that previous application of *Selective Catalytic Reduction (SCR)* in diesel vehicle

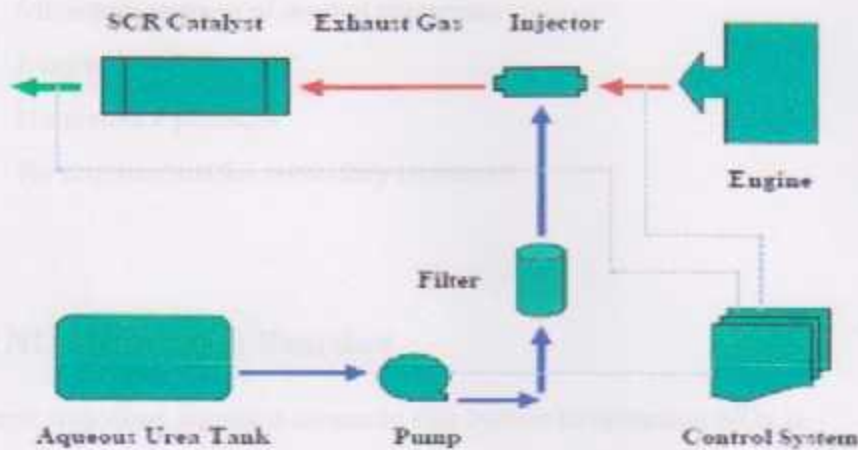

Figure (5.2) previous application of urea injection in diesel motor.

### 5.3 NO<sub>x</sub> Optimizer Injection of Urea CO(NH<sub>2</sub>)<sub>2</sub>

#### 5.3.1 Features and Benefits

NO<sub>x</sub> is reduced by injection of urea into the catalytic converter. Pulverized urea is fed with air to the upper combustion chamber. The urea reacts with flue gases NO and NO<sub>2</sub> producing nitrogen gas, vaporized water and carbon dioxide. The reaction speed and efficiency are highly dependent upon the reaction temperature.

The reaction has a clear optimum at 950 - 1000°C. There is a possibility of NH<sub>3</sub> slip if the temperature is lower than the optimum; while at higher temperatures the reaction efficiency decreases rapidly.

The application of selective control reduction (SCR) has many benefit:

- Optimum NO<sub>x</sub> reduction .
- No NH<sub>3</sub> slip .
- Minimum amount of wasted reactants .
- Easy to handle
- No malodor problem.
- No requirement for secondary treatment

### 5.3.2 NO<sub>x</sub> Reduction Reaction

The most important equation occurs in this system to reduction NO<sub>x</sub> is

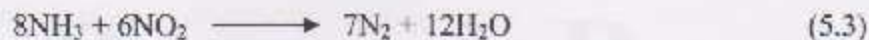

### 5.3.3 Urea Injection Requirements

The application of selective control reduction has many requirements must take into account:

- Inject sufficient urea to convert NO<sub>x</sub> at maximum conversion rate.
- Avoid excessive urea to minimize NH<sub>3</sub> slip.
- Control urea injection rate to match the NO<sub>x</sub> emission peaks and dips.

### 5.3.4 Solution Experiments

There are two way to solution of urea :

- Binary solution: UREA / Water.
- Ternary solution: UREA/Ethanol/Water.

## 6.1 Introduction

In the previous chapter, the concept of a catalytic converter has been explained. The main objective of this project is to design and develop a catalytic converter system for a car engine. The project is divided into two main parts: the design and the implementation. The design part includes the selection of the catalyst material, the design of the reactor, and the design of the control system. The implementation part includes the fabrication of the reactor, the installation of the catalyst, and the testing of the system.

# Chapter Six

## Building Project and Result

- Introduction.
- principle Work of Project.
- Electrical system for sensors.
- Data and Signal Handling.
- Efficiency of Catalytic Converter.



## 6.1 Introduction

In the selective control reduction (SCR) system has been applied the system to diesel vehicle in this project has been designed and applied on a gasoline vehicle (Hyundai Getz 2003) to limit and reduce the concentrations of nitrogen oxides (NO<sub>x</sub>) from the exhaust outside.

After apply the system on the vehicle mentioned was access to good results up to 60% efficiency using urea injection only.

Development the system by installed (CO) sensors before and after the converter to measure the concentration of CO gas evaluate performance of catalytic converter. Since these sensors were not present in the vehicles before.

## 6.2 Principle Work of Project

This experimental work is based on installing gas analysis system (carbon monoxide sensor) at the inlet and outlet of catalytic converter for measure the efficiency (performance) of the catalytic converter this would assist in suggesting performance improvement measure . The carbon monoxide (CO) sensors record the voltage signals before and after catalytic converter, the resulting data between inlet and outlet is deferent to decreasing this is indicator to the efficiency of catalytic converter , as shown in left side in the figure (6.1).

Also to reduce toxic gas of NO<sub>x</sub>, the urea is first mixed with water about 33% then it is pumped using electrical pump and pass through urea filter then the pressure is measured by pressure gauge.

The mixture injected inside catalytic converter by using injector controlling manually that inject at pressure 3.7 bar, by pressure regulator is regulate pressure of the system to maintain the system pressure about 3.7 bar to avoid damage the system , the figure (6.1) explain idca work of the project.

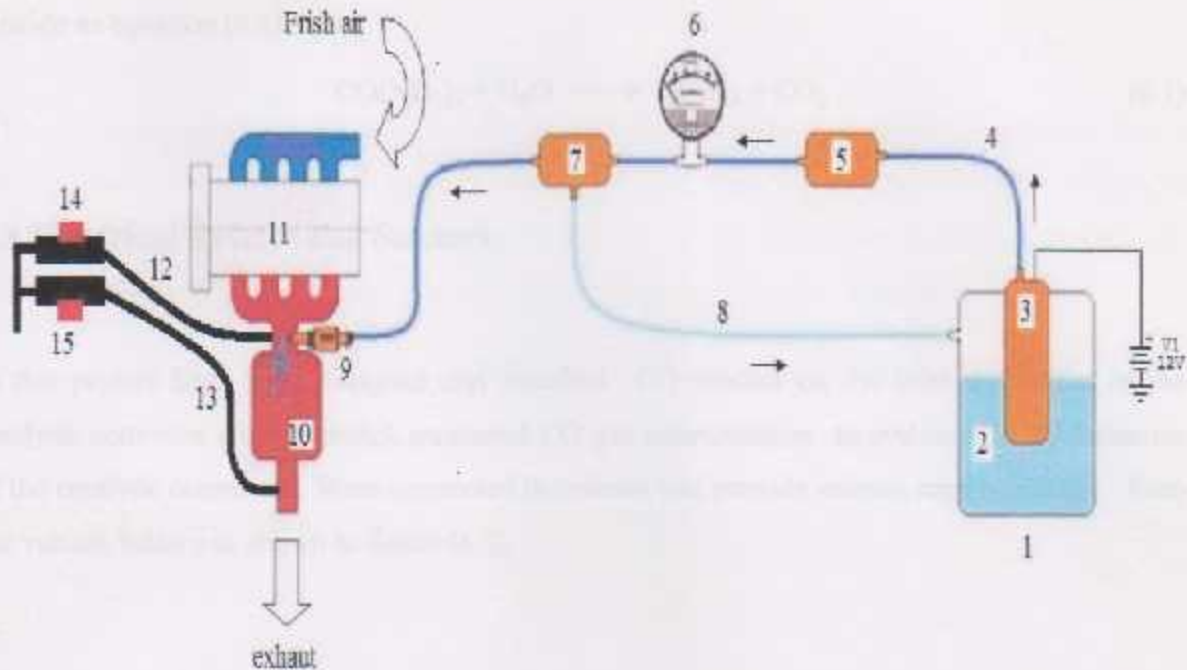
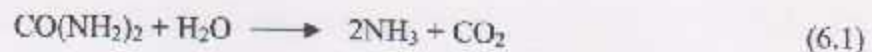

**Figure (6.1):** flow sheet of the project

### Component of System

- |                            |                                    |
|----------------------------|------------------------------------|
| 1- Urea Tank               | 9- Urea Injector                   |
| 2- mixture of Urea & water | 10- Catalytic Converter            |
| 3- Electrical Pump         | 11- gasoline Engine                |
| 4- High Pressure Pipe      | 12- Emission Pipe before Cat. Con. |
| 5- Urea Filter             | 13- Emission Pipe before Cat. Con. |
| 6- Pressure Gauge          | 14- CO Sensor before Cat. Con      |
| 7- Pressure Regulator      | 15- CO Sensor after Cat. Converter |
| 8- Return Pipe             |                                    |

When urea mixture is injection it is vaporized then it dissociation to ammonia (NH<sub>3</sub>) and carbon dioxide as equation (6.1) .



### 6.3 Electrical System For Sensors

In this project have been designed and installed CO sensors on the inlet and outlet of the catalytic converter through which measured CO gas concentration to evaluate the performance of the catalytic converter . Were connected the circuit and provide sensors supply voltage from the vehicle battery as shown in figure (6.2).

A connection circuit drawing by circuit maker program of carbon monoxide (CO) sensor to measure the concentration of carbon monoxide that exit from the internal combustion engine explain in the figure (6.2), and record the signals of carbon monoxide (CO) sensors before and after catalytic converter expressed output signals and taken two devices voltmeter. The *signal 1* indicate to signal out from sensor before catalytic and *signal 2* indicate to signal out from sensor after catalytic.

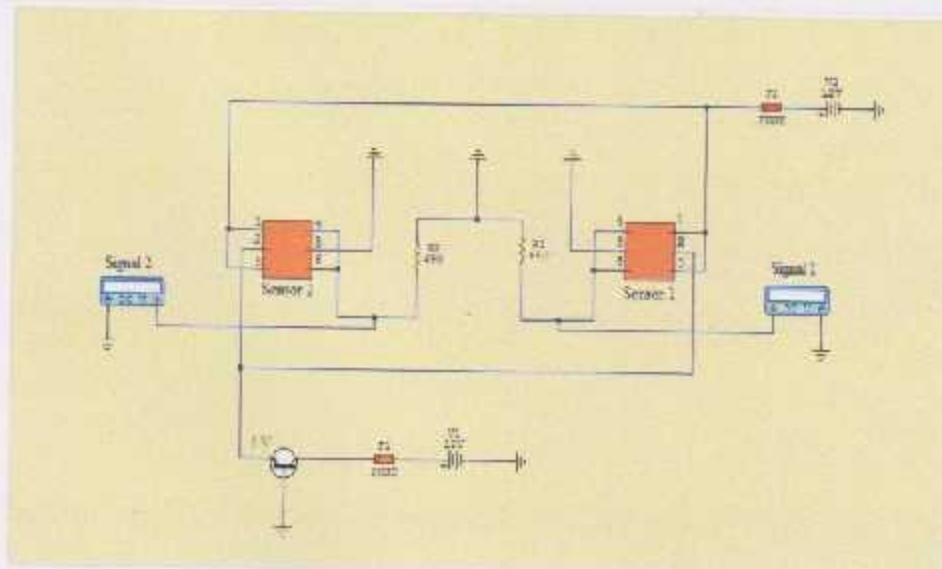

**Figure (6.2):**  
Simple circuit  
for carbon  
monoxide sensor

## 6.4 Data and Signal Handling

The output signals from carbon monoxide sensors that it result when do the experiment side of the project is explain in the table (6.1) ; from this table were noted signal of carbon monoxide sensor before catalytic converter is high-value but signal of carbon monoxide sensor after catalytic converter is low-value, This result proves the efficiency of catalytic converter

*Table (6.1): CO signal versus engine speed (before and after catalytic converter)*

Where temperature: indicator to room temp. sensors

RPM	CO signal before cat.con(V)	CO signal after cat .con(V)	Temp(C°)
750	10.4	1.63	56
1000	10.2	1.28	76
1500	10.57	1.09	92
2000	11.47	0.93	117
2500	10.9	0.87	143
3000	10.3	0.85	151
3500	10.2	1.1	197

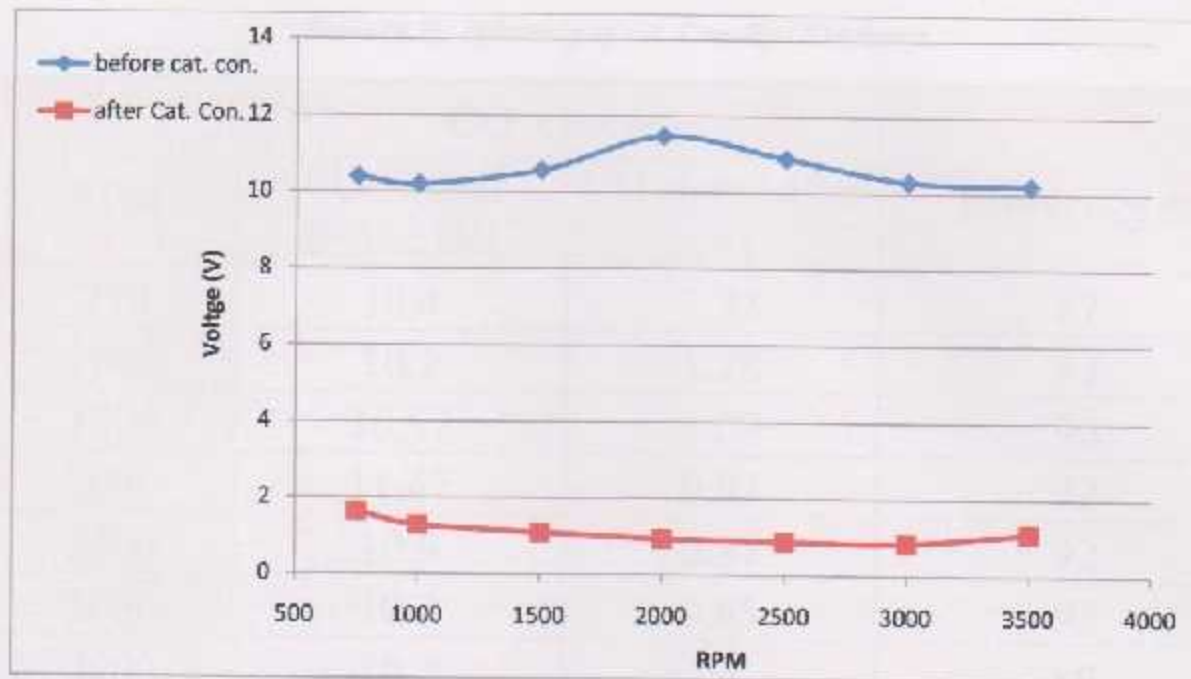

Figure (6.3): Signal of CO sensors (in volt) versus engine speed before and after cat. Converter

This curve shows the relationship between engine speed and a signal voltage that resulted when it was done experimentally, also been observed through the readings from the experiment that the curve before the catalytic converter is high but when we record the data after catalytic converter we notice that is low ,this explain the efficiency of catalytic converter.

## 6.5 Efficiency of Catalytic Converter

In this project was calculated efficiency of catalytic converter by two method

### 6.5.1 Efficiency By Using Carbon Monoxide Sensors

The equation that expresses the efficiency of catalytic converter is:

$$\epsilon(\text{CO}) = ((\text{CO in} - \text{CO out}) / \text{CO in}) * 100\%$$

From this equation we can calculate the efficiency of catalytic converter as shown in the table(6.2).

**Table (6.2): Efficiency of cat. Con. By CO sensors**

RPM	CO cat.con		Efficiency %
	CO signal before (V)	CO signal after (V)	
750	10.4	1.33	87
1000	10.2	1.28	87
1500	10.57	1.09	90
2000	11.47	0.93	92
2500	10.9	0.87	92
3000	10.3	0.85	92
3500	10.2	1.1	89

The resulted data that output when doing the experiment as shown in the table(6.3) below, notice that the value of carbon monoxide, hydrocarbon and oxide of nitrogen before cat. con. is high-value but after catalytic converter is low-value ,this explain the efficiency of catalytic converter .

**Table (6.3): construction of emission (CO), (CO<sub>2</sub>)and (HC)**

RPM	CO%	CO%	CO <sub>2</sub> %	CO <sub>2</sub> %	HC ppm	HC ppm
	before	after	before	after	before	after
750	0.64	0.34	6.55	4.04	58	42
1000	0.51	0.21	5.53	5.81	55	38
1500	0.44	0.08	4.97	6.57	55	36
2000	0.59	0.09	5.36	8.44	56	37
2500	0.44	0.03	5.56	8.16	57	36
3000	0.4	0.04	6.06	8.47	54	41
3500	0.42	0.05	5.94	7.59	60	43

From the table (6.4) we can draw three curve as shown in the figure (6.4), (6.5) and (6.6) respectively

Where; figure (6.4) explain the relationship between engine speed and carbon monoxide emission, figure(6.5) explain the relationship between engine speed and carbon dioxide emission and the last figure (6.6) explain the relationship between engine speed and hydrocarbon.

From these figures we notice that the emission before catalytic converter is normally high but after catalytic converter is low.

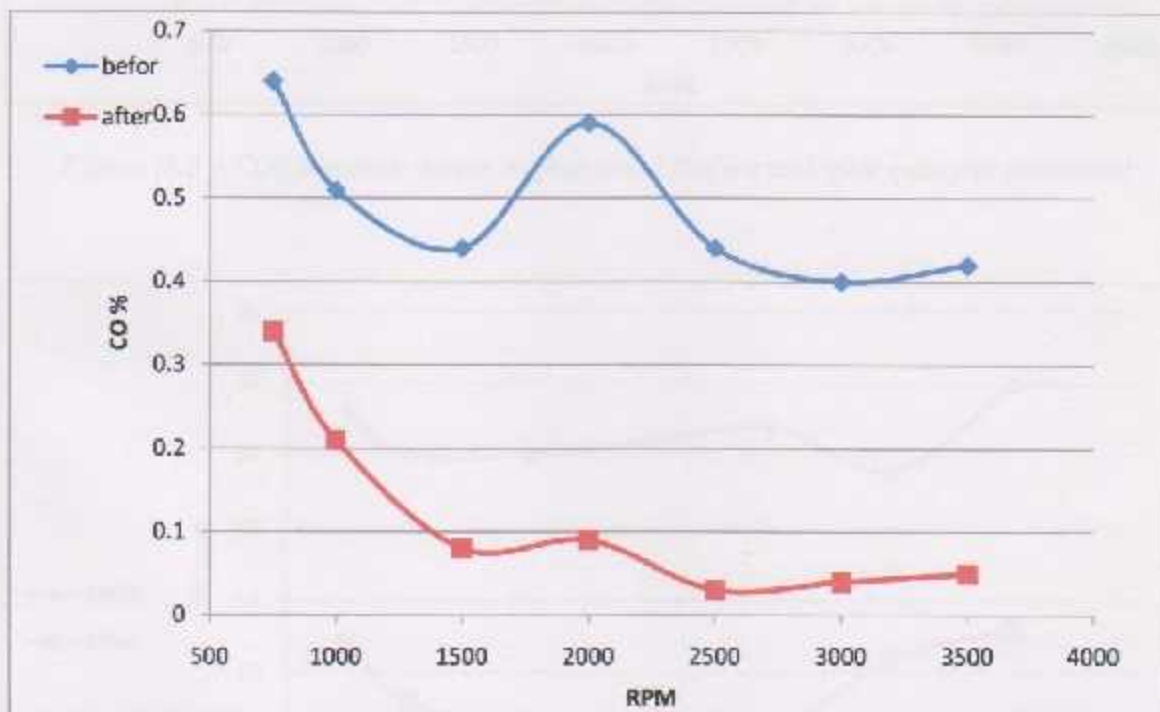

**Figure (6.4):** CO emission versus engine speed (before and after catalytic converter)

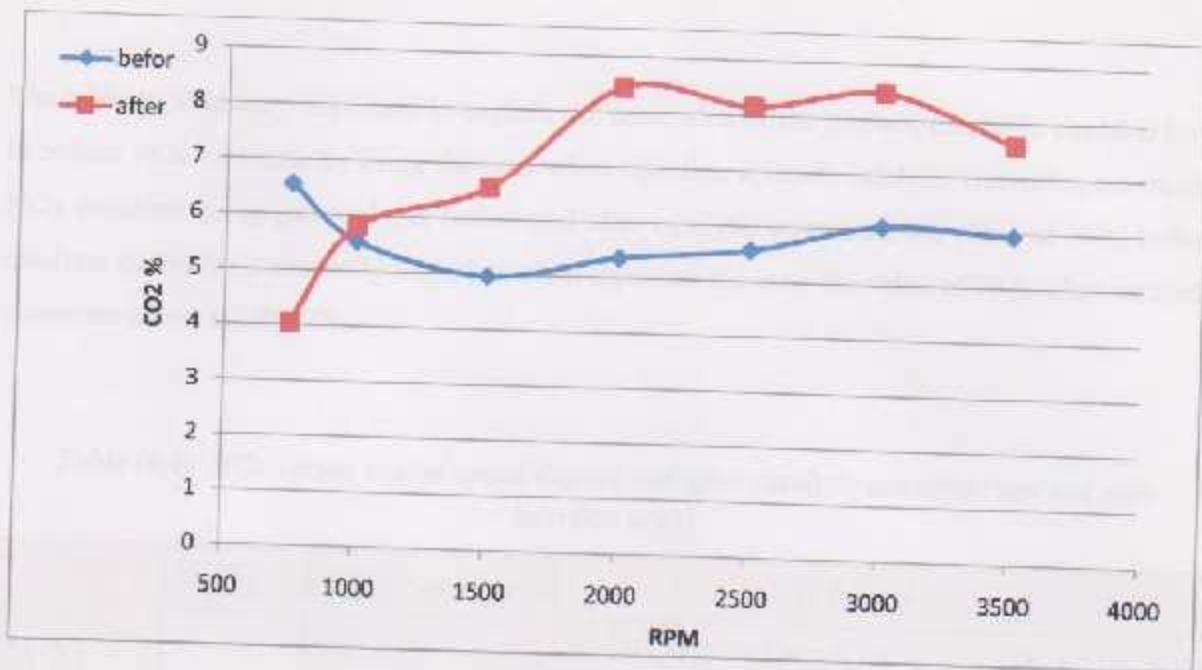

Figure (6.5): CO2 emission versus engine speed (before and after catalytic converter)



Figure (6.6): HC emission versus engine speed (before and after catalytic converter)



The table (6.5) is very important to explain the main idea of the project; this table explains how to reduce NOx emission by using the urea when injection it inside catalytic converter, we record NOx emission using gas analyzer before and after catalytic converter, the value of NOx before catalytic converter is normally high, but when injection the urea the value of NOx after catalytic converter is low nearly 40%.

**Table (6.4):** NOx versus engine speed (before and after catalytic converter w/o and with injection urea)

RPM	NOx before cat.con.	After cat.con.	
	before cat.con(ppm)	without injection urea(ppm)	with injection urea(ppm)
750	320	187	48
1000	424	380	79
1500	520	430	146
2000	568	480	257
2500	690	414	352
3000	754	406	344
3500	793	215	116

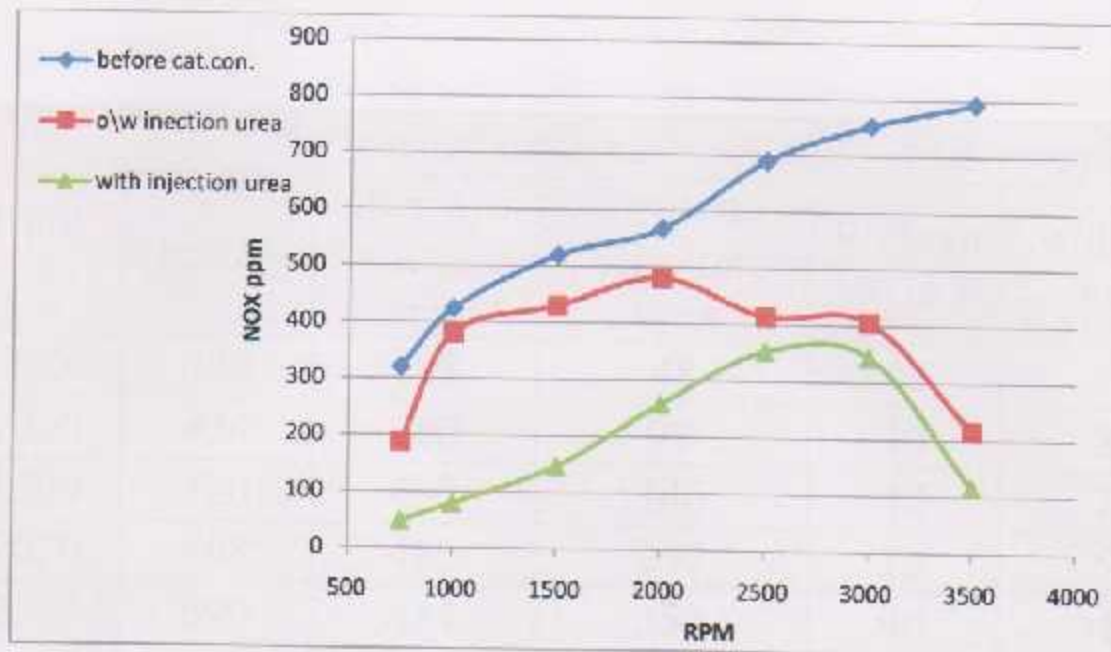

Figure (6.7): NOx emission versus engine speed (before and after catalytic converter w/o and with injection urea)

### 6.5.2 Efficiency By Oxide of Nitrogen

The equation that expresses the efficiency of catalytic converter is:

$$\epsilon(\text{NOx}) = \frac{(\text{NOx in} - \text{NOx out})}{\text{NOx in}} * 100\%$$

From this equation we can calculate the efficiency of catalytic converter as shown in the table

RPM	NOx cat. Converter			Efficiency %	
	before	after w/o urea	after with injection urea	Without add urea	with add urea
750	320	187	48	42	85
1000	424	380	79	10	81
1500	520	430	146	17	72
2000	568	480	257	15	55
2500	690	414	352	40	45
3000	754	406	344	46	54
3500	793	215	116	73	85

*Table (6.5): Efficiency of system with and without injection urea to reduce NOx*



*Figure (6.8) sample result data of the project by gas analyzer*



*Figure (6.9) picture of the project*



*Figure (6.10) Injection system of urea*



*Figure (6.11) Mixture Urea and water*

Conclusions drawn from this project included the following:

- The results of the survey of hospital CFOs showed that the majority of respondents (approximately 70%) are well-satisfied with the performance of their CFOs.

## Chapter Seven

## Conclusion and Recommendations

- The survey results of CFOs are consistent with other studies.

## 7.1 Conclusion

Conclusions reached in this project included the following:

- Development the system by installed (CO) sensors before and after the converter to measure the concentration of CO gas evaluate performance of catalytic converter. Since these sensors were not present in the vehicles before.
- This experimental work is based on installing gas analysis system (carbon monoxide sensor) at the inlet and outlet of catalytic converter for measure the efficiency (performance) of the catalytic converter this would assist in suggesting performance improvement measure . The carbon monoxide (CO) sensors record the voltage signals before and after catalytic converter, the resulting data between inlet and outlet is deferent to decreasing this is indicator to the efficiency of catalytic converter.
- Also to reduce toxic gas of NO<sub>x</sub>, the urea is mixed with water about 33% .

## 7.2 Recommendations

The recommendation reached in this project included the following :

1. Carbon monoxide sensor cannot withstand temperatures above 200 ° C.
2. Using the injector of urea that withstands temperature above 700 ° C.
3. To be controlled in the injection of urea is electronically.
4. Enter the signal of carbon monoxide sensor to the electronic control unit(ECU).
5. Provide cooling for the carbon monoxide sensors.
6. controlled manually injector of urea leads to increase the proportion of urea within the catalytic converter and causing it to produce NH<sub>3</sub> slip.



# Reference

## Books

[1] **Advanced Automotive Fault Diagnosis, Second Edition, Tom Denton BA, MSAE, MIRTE, CERT, ED, 2003.**

[2] **Internal combustion engine fundamental, Second Edition, Dr V Ganesan, Indian Institute of technology, Madras, 1996.**

## Appendix A

## Links

[3] <http://www.AAICar.com> .

[4] <http://auto.ihs.com>.

[5] <http://shieldedpair.net>.

[6] [http://en.wikipedia.org/wiki/Air-fuel\\_ratio\\_and\\_urea](http://en.wikipedia.org/wiki/Air-fuel_ratio_and_urea).

[7] <http://forum.zira3a.net/showthread.php?t=8778>.

[8] [http://en.wikipedia.org/wiki/selective\\_catalytic\\_reduction](http://en.wikipedia.org/wiki/selective_catalytic_reduction).

### Properties

Class	200
Number of members	10 (100% of 10)

### Construction

Number of members	100% of 100%
Typical member length	100%

### Performance

Number of members	100% of 100% (100% of 100%)
Number of members	100% of 100%

## Appendix A

### Member Characteristics

Member length	100% of 100%
Typical member length	100% of 100%
Typical member length	100% of 100%
Typical member length	100% of 100%
Typical member length	100% of 100%

### Notes

Typical member length	100% of 100%
Typical member length	100% of 100%
Typical member length	100%

### Construction

Number of members	100% of 100%
Number of members	100% of 100%
Typical member length	100%
Typical member length	100%
Number of members	100% of 100%

### **Dimensions**

---

Chip size:	2x2 mm
Including header: O:	10 mm, height: 11 mm

### **Operational Conditions**

---

Operation temperature range:	250°C - 300°C
Typical operation temperature:	270°C

### **Environmental Conditions**

---

Ambient temperature range:	-40°C - 120°C (lower than op. temp.)
Ambient humidity:	0 - 95% RH

### **Electrical Characteristics**

---

Power consumption:	35 mW at 270°C
Typical sensor resistance during operation in air (50% RH):	100 k $\Omega$ range
Typical sensor resistance during operation in 30 ppm CO (50% RH):	1 k $\Omega$ range
Signal output component: Resistance	

### **Heater**

---

Typical heater voltage:	2.3 V for 270°C
Temperature coefficient rel. to R(20°C):	TC $\approx$ 700 ppm/K
Typical heater resistance at RT:	95 $\Omega$

### **Sensing Properties**

---

Concentration range:	Can withstand 1% CO in air
Sensitivity range:	0.5 - 500 ppm
Typical response / recovery time:	Seconds
Expected lifetime:	Years
Cross sensitivity:	Limited cross sensitivity to water

### **Packaging Options**

---

Standard TO-39 (solid TO-5) package with protection membrane.

Pre-mould packages.

Chip on board solutions.

### **Restrictions:**

---

Contact of the sensitive layer with liquids shall be avoided