

بسم الله الرحمن الرحيم



Palestine Polytechnic University

Collage of IT and Computer Engineering

Computer System Engineer

**Introduction to Graduating Project**

**WALK TO GENERATE POWER**

### **Team Members**

AmalBadarin

Wala' Zayed

### **Supervisor**

Dr. Amal Al-Dweik

## **DEDICATION**

We would like to dedicate our work to our parents and to dear country Palestine.

## **ACKNOWLEDGMENT**

The satisfaction that accompanies the successful completion of any task would be incomplete without the mentioning of the people whose guidance and encouragement made it possible. We express our earnest gratitude to our guide, Dr. Amal Al-Dweik. Also, Eng-AlaaTamimi, and EngWaelTakrori, we are grateful for their cooperation and valuable suggestions.

## **ABSTRACT**

Demand on energy has been adopted throughout the world, and traditional methods of generating power have a direct impact on environment. So, here we are proposing a non-conventional method of power generation that utilizes wasted energy in an un-interrupted way and cope with the increasing demand of energy.

The basic concept of this system is capturing unused energy when a person walks on a certain arrangement and converting it into electrical energy. The power generated with this non-conventional method depending on the human daily activity (walking). This energy is then stored in a Lead Acid battery so we can charge any device such as mobile phones. Also this system enables us of viewing the amount of output voltage using an LCD. This project would be installed in crowded cities like Hebron and Gaza strip in places where people exists the most, for example: stations, entries, stairs, restaurants, and streets. We made such an arrangement so we can obtain an efficient and reliable system using embedded technologies. The ATmega328 microcontroller which is the heart of the circuit, allows dynamic and fast control of all of the functions, the LCD makes the system user friendly.

At the end of implementation, we were able to develop a compatible system that serves us in many ways after installing it at homes, schools, and other places where the people move around. The system successfully generates power and the results were approved.

# **1 INTRODUCTION**

## **1.1 Overview**

Energy crisis is a major concern in today's world. As the demand of energy is increasing day by day, energy is wasted in many ways. So we think that implementing a renewable source of energy is the optimum solution to deal with this problem. Footstep power generation would be an effective method to generate electricity [1]. In this project, we could use a technique that generates power through footsteps, which enables the use of energy that is wasted when a person walks on certain arrangements like footpaths and stairs. We could install this project, in highly crowded areas such as stations, entries, etc. So, we can obtain the maximum amount of wasted energy.

## **1.2 Motivation**

Man has been looking for energy from the starting of human beings. This demand is always increasing; at the same time the wastage of energy is also increasing. So, thinking of ways to reform this wasted energy back to usable form is so helpful. Generating power using conservative methods is becoming deficient. So, our project is a new way to overcome the increasing demand of energy easily by utilizing human force [2].

## **1.3 Importance**

The Fuel deposit will soon extinct, in addition of many petrol resource, so our project is non-conventional and non-polluting form of power system to be applied in crowded cities same as Hebron and Gaza strip that would have also a low chance of using petroleum products in future.

In our system we try to utilize the wasted energy of foot that is produced by human motion and converting mechanical energy into electrical energy; thus reduce the dependency on conventional electricity. This system is reliable, economical and eco-friendly system [3], which means it has no harm upon the environment.

## 1.4 Aim

Our aim is to design and develop almost free noise power generator that depends on human footsteps, also to create a model that would show the feature of the system and works depending on our need.

In order to reach this valuable aim, these objectives should be achieved:

- Collect and arrange the electrical system in proper order that will transfer mechanical energy into electrical energy.
- Attach the Piezo sensors to the platform in suitable arrangement.
- After that, voltage is produced through the steps and stored in the lead acid battery.
- Finally, this voltage could be used in many applications like charging themobile battery.

## 1.5 System Description

- The system design is based on the foot force applied on the” biezoelectrical” sensors which are placed bellow the platform. The force is converted to electrical energy and that process is known as the piezoelectric effect. Then the energy provided to the circuit allows user to monitor the voltage on drive DC loads. The voltage is stored in the Lead Acid battery. Finally, the circuit is connected to USB cable for charging as shown in figure 1.5. All of these components convert voltage to power that enables the charging of devices like: Mobile, Tablets, MP3 devices, and charger light. [4]. Fig 1.1 shows a simple overview of our project.

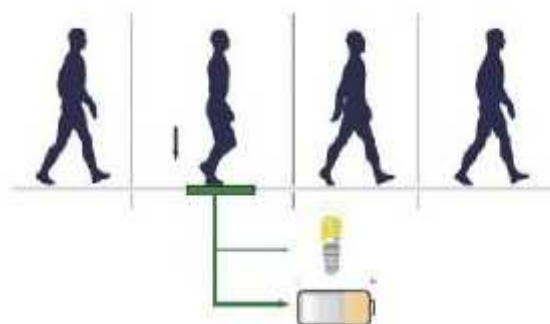

**Fig.1.1**Description of the system

## **1.6 Problem Statement**

Palestine is having long and frequent black days of power crisis these times, especially in Gaza strip, where the occupation forces are supplying them power for only 3-4 hours a day. So, demand is far away from that provided for them. Other cities like Hebron are facing power cut-off for several times during a month. Therefore, utilizing this power resource is good for our country in every field.

However, although that the produced power of a single model is not enough to solve this problem, the system can be customized and enhanced to give more energy for more extended usages, such as applying this single model into several places in large numbers to obtain the amount of power needed. The amount of power that would be obtained will be shown in section [5.2].

## **1.7 Problem Analysis**

The system will be installed in public places like shopping malls or any crowded place, power generated varies with different number of steps, also depending on the pressure applied, the harder you hit on the platform, the more voltage will be generated. So, at least the minimum voltage we can get per 1 step on a single piezo sensor is 1V [3] based on multiple parameters that will be discussed in details in section [5.2]. So, imagine how much power we could produce if we apply this system in all of the shopping mall areas.

## **1.8 System Requirements**

### **A. Functional requirements:**

Foot step power generator is a system that can produce power from the human footstep using a “Piezoelectric sensors” which arranged under a glass platform in parallel-series connection.

The produced electrical power then stored in 12V rechargeable battery which helps the users to charge any lode with a USB cable that attached to the system.

The system is ATmega328 microcontroller based which helps to display the generated voltage from footsteps along with the number of steps on the system LCD and make sure of battery safe charging.

## B. Nonfunctional requirements:

Our system is:

1. Simple and easy to use, it depends on daily human activity (walking).
2. Secure, it is totally free of risk. The system will not produce any harm to people.
3. Effective, it will help the users to charge any attached load.
4. Reliable, it will produce the needed amount of power for charging in fast way.
5. Extendable, we could extend the system to be used in street lighting.

Also the electrical components of the system are low cost as it's showed in details in section [1.10].

## 1.9 Expected Results

- The system will be installed in public crowded places as: shopping mall, entrance of restaurants and street sides. That would help to generate power in huge amount.
- The system will be simple, reliable, environment-friendly and very easy to use.
- Mostly, the system will give a voltage of 14V per 1 step as we are showing in section [5.2].
- As our system is applied in high populated country. It will make a huge economic difference according to its low cost

## 1.10 Cost Calculations

In table 1.10, we estimated the cost of each component in details, noting that we have got a fund from the deanship of research of 165 JD.

**Table 1.10 Components' cost**

Name of equipment	Quantity	Price(JD)	Total(JD)
Piezoelectric sensors	4	1	4
UNO(ATmega328)	1	16	16
LCD16*2	1	5	5
PCB	1	8	8
Battery	1	6	6
Platform	1	16	16
12V Adaptor	1	8	8



Resistors	10	0.25	2.5
Capacitors	5	0.25	1.25
Transistors(7805)	2	0.75	1.5
IC Base (28-pin)	1	0.5	0.5
Diodes	4	0.25	1
LCD Strip (16-pin)	1	0.5	0.5
Crystal (16-MHZ)	1	1	1
LED Strip	1	2	2
USB Cable	1	2	2
USB Connector	1	0.25	0.25
LEDS	3	0.25	0.75
Push Button (2-pin)	1	0.25	0.25
Soldering wire	1m	1	1
PCB Connectors (2-pin)	4	0.25	1
		<b>Total</b>	<b>78.5</b>

## **2BACKGROUND**

### **2.1 Theoretical Background**

Earlier researchers had work on the conversion of dynamic energy to electrical by human movement, Jeff Krupen-kin and Ashley Taylor proposed a new technique called reverse electro-wetting which states that whenever there's a vibration on a platform caused by human motion could result in producing electrical energy. [5]

### **2.2 Literature Survey**

JedolDayou (2016) has stated the usage of Piezoelectric sensors. This includes how Piezoelectric sensors can be optimized to generate power. He showed that a proper configuration of Piezo film can generate enough power that can be stored in a battery for later usage. V. Prasannabalaji (2013) discussed the prototype of a Piezoelectric generator that gathers mechanical vibrations energy available on stairs by putting these sensors on the stair steps to get signals when people walks on them. [6]

Another project which influenced us to go on with our idea, is the floor tiles that use foot power to light up cities, this project was applied by Laurence Kemball-Cook in Britain. Whenever someone steps on the tile, they generate seven watts of power. The energy is stored within batteries, and then used to power lighting when it's needed. We wanted to apply this idea in our countries and add an LCD display to show us the amount of charge generated and the number of steps.

### **2.3 Description of the System Parts**

As we mentioned before, we would use an LCD display, which makes our project user friendly. For that purpose, we would use a microcontroller that helps us displaying the amount of output voltage on the LCD and also allows users to monitor the voltage. Since we are using a rechargeable battery, once the battery is fully charged, additional power applied to it will be converted to heat. This will probably damage the battery over time, and will even explode. So, this microcontroller would controls charging and discharging of the battery to protect it from over charging effects.

Our system can be done using ArduinoUNO, but instead, we would use the ATmega328 microcontroller since it is the cheaper option. ATmega328 chip is a controller which gets programmed by mounting it over ArduinoUNO board. After that we can use it (the ATmega328 chip) directly in our project.

Instead of Arduino board we would use the PCB (Printed Circuit Board), which helps us connecting all other components easily. PCB is cheaper and faster than other wiring methods, as components are mounted and wired in one operation. [13]

## **2.4 Design Constraints**

In general, our system works properly almost in all conditions, but there are some constraints that must be considered:

- Space constraints: the system would not be useful in small space places, because the smaller the model, the less the piezo sensors that would be mounted on it, thus the less the power produced[12], as shown in section [5.2].
- There is no minimum number of steps to start generating power. Power will be generated from the first hit.
- Certain number of steps should be obtained so the system can be ready to charge specific devices as discussed in section [5.1].

## **3HARDWARE DESIGN**

### 3.1 Methodology

The basic concept of this system is capturing unused energy from surrounding system and converting it into electrical energy. The power generated with this non-conventional method depending on the human daily activity (walking). [7]

### 3.2 Detailed Design

Fig. 3.1 is the block diagram that shows the components and connections in general:

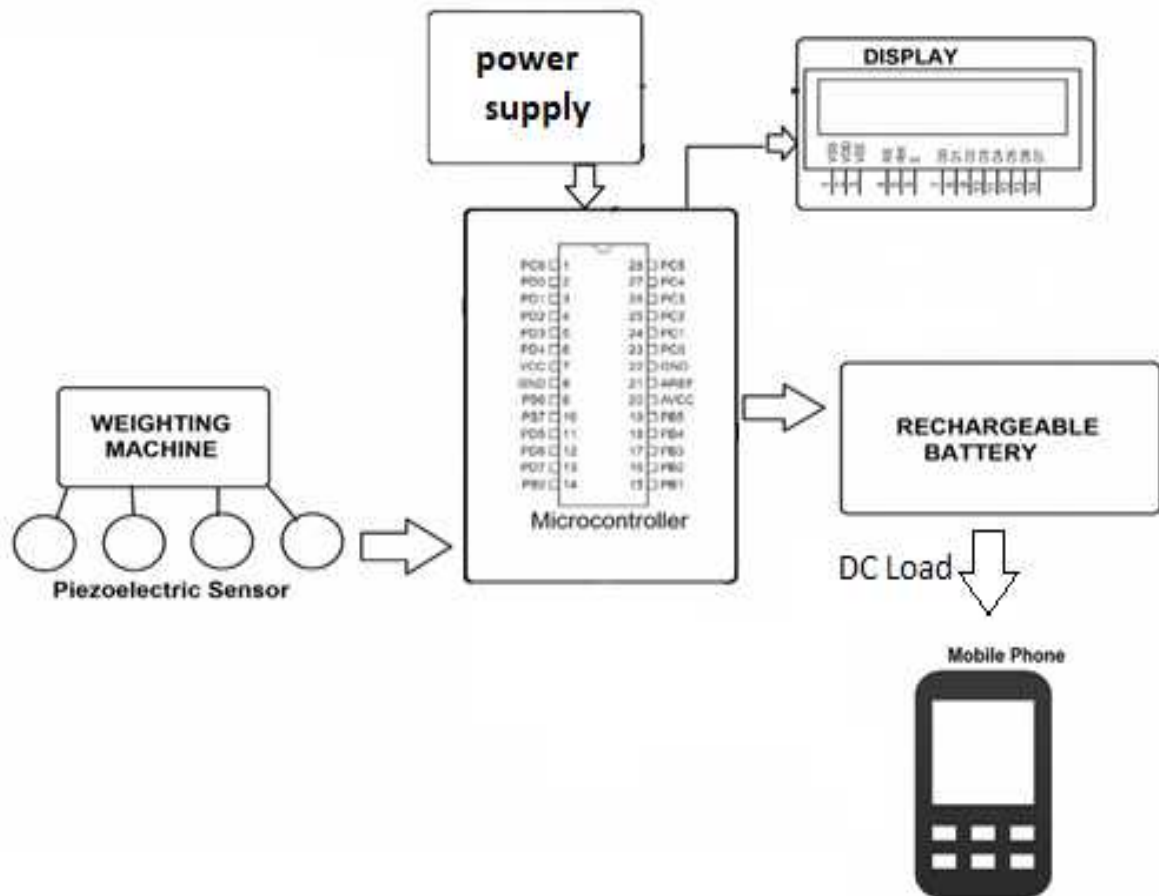

Fig. 3.1 Block diagram

Power Supply

Here we are using an adapter of 12V and 1A as a power supply to turn on the system. This adapter contains a transformer to convert the mains electricity voltage (220V) to a lower voltage (12V), a rectifier to convert it to pulsating DC, and a filter to smooth the pulsating waveform to DC, with residual ripple variations small enough to leave the powered device unaffected.

### Piezoelectric sensor

As we mentioned before, the Piezo electrical sensors are placed under insulating material (platform) and pressure is created by footstep. The property of piezoelectric material is to generate electricity when we apply pressure. [7]

A piezo sensor can be made out of different materials; each material gives an amount of output voltage that varies than the other when pressure is applied. An analysis on the most two commonly available piezoelectric material PZT and PVDF was done [8], the voltmeters had been connected across both of them for measuring voltages and an ammeter is connected to measure the current [8]. The characteristic behavior for each material is shown in the figures 3.2 and 3.3. So, in our project we used the PZT piezo sensor that gives the better output voltage.

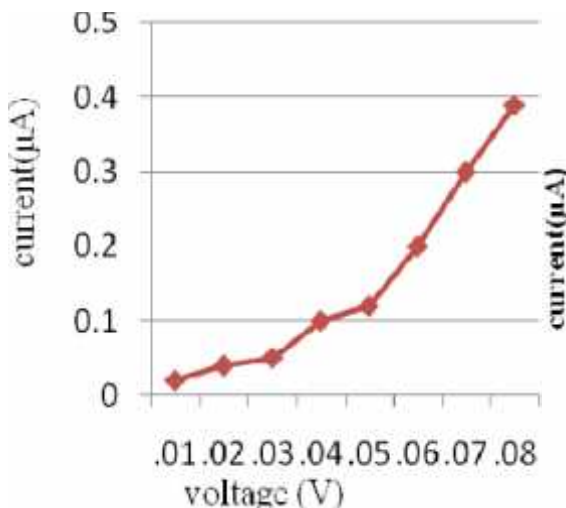

Fig. 3.2 V-I graph of PVDF material [8]

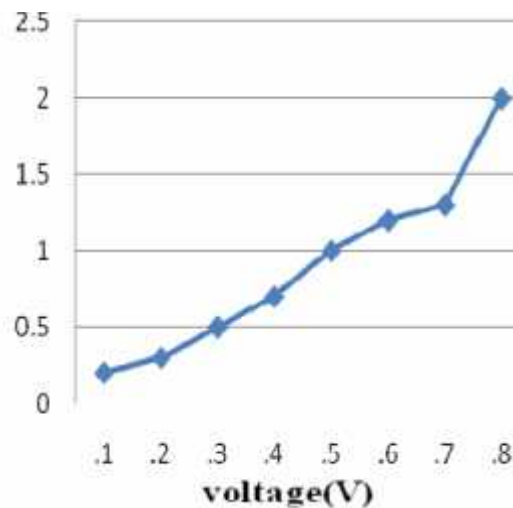

Fig. 3.3 V-I graph of PZT [8]

The second concern is to determine the suitable shape of the connection for the PZT, which is a series-parallel connection that gives the appreciable voltage and the necessary current as discussed in details in section [5.2] after doing several experiments.

### Battery

The system battery consists of electrochemical cells to store electricity in a single unit. Some batteries are used once and some of them are rechargeable. [9]

Here we need a rechargeable one to be able to charge it again when it's empty after consuming it by users.

### **Microcontroller**

Considering multiple types of microcontroller like: ATmega168 which will need double programming space that the ATmega328 need, also there is Pic18f2550 which has less EEPROM and considered more expensive than ATmega328. The ATmega328 was the most suitable choice. [11]

The microcontroller which is used to monitor the voltage that charges the rechargeable battery. It then, displays the amount of charging on the LCD. The microcontroller also helps controlling charging and discharging of the battery to protect it from over charging and avoiding the damage could be caused.

### **LCD Display**

There are many choices for LCD like: 2x40 without backlighting, 1x16 which has only one row to show and finally 2x16 which is the most common type that can cover the system needs in very simple way.

The LCD is interfaced with the microcontroller to display the battery voltages and the number of steps.

### **USB Cable**

The cable is used to charge any kind of load that could be attached, so the shape of the cable depends on the attached loads like: mobile and lights...etc.

### **Circuit Diagram**

Fig. 3.4 shows the circuit diagram that we built our PCB depending on:

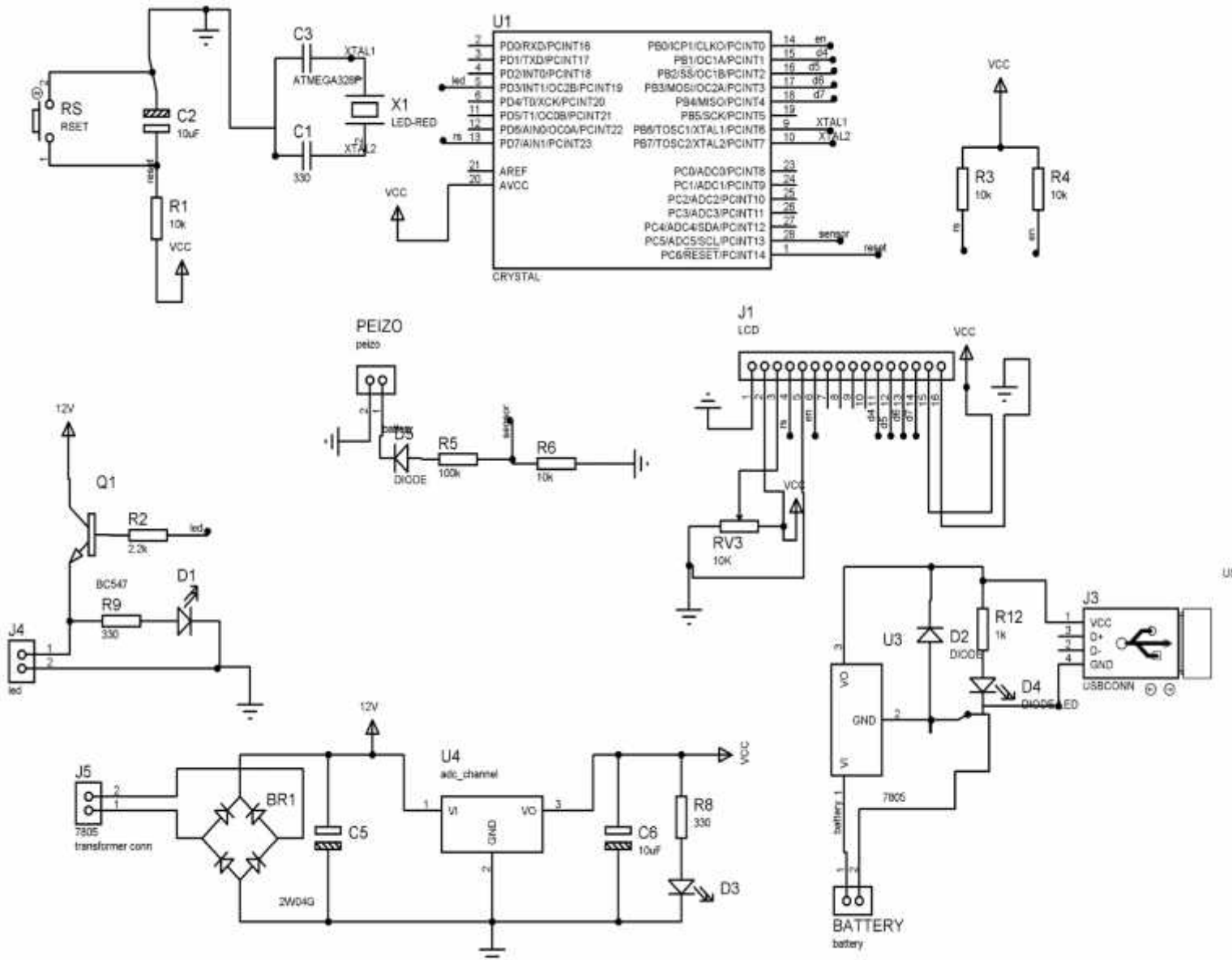

Fig. 3.4 Circuit diagram

## User Interface Design

There will be posters instilled wherever the system is applied to give the users instructions on how to use the system properly. The posters will be as the following:



WALK TO GENRATE POWER

Dear users,

As you step on the following pathway,  
Power will be generated using your  
footsteps.

You can charge your mobile phone or any  
device through a USB cable.

Pleas attach the device to the cable to  
charge.

Enjoy your time

And be useful 😊

**Fig. 3.5**User interface



The following flowchart is the description of the project working mechanism:

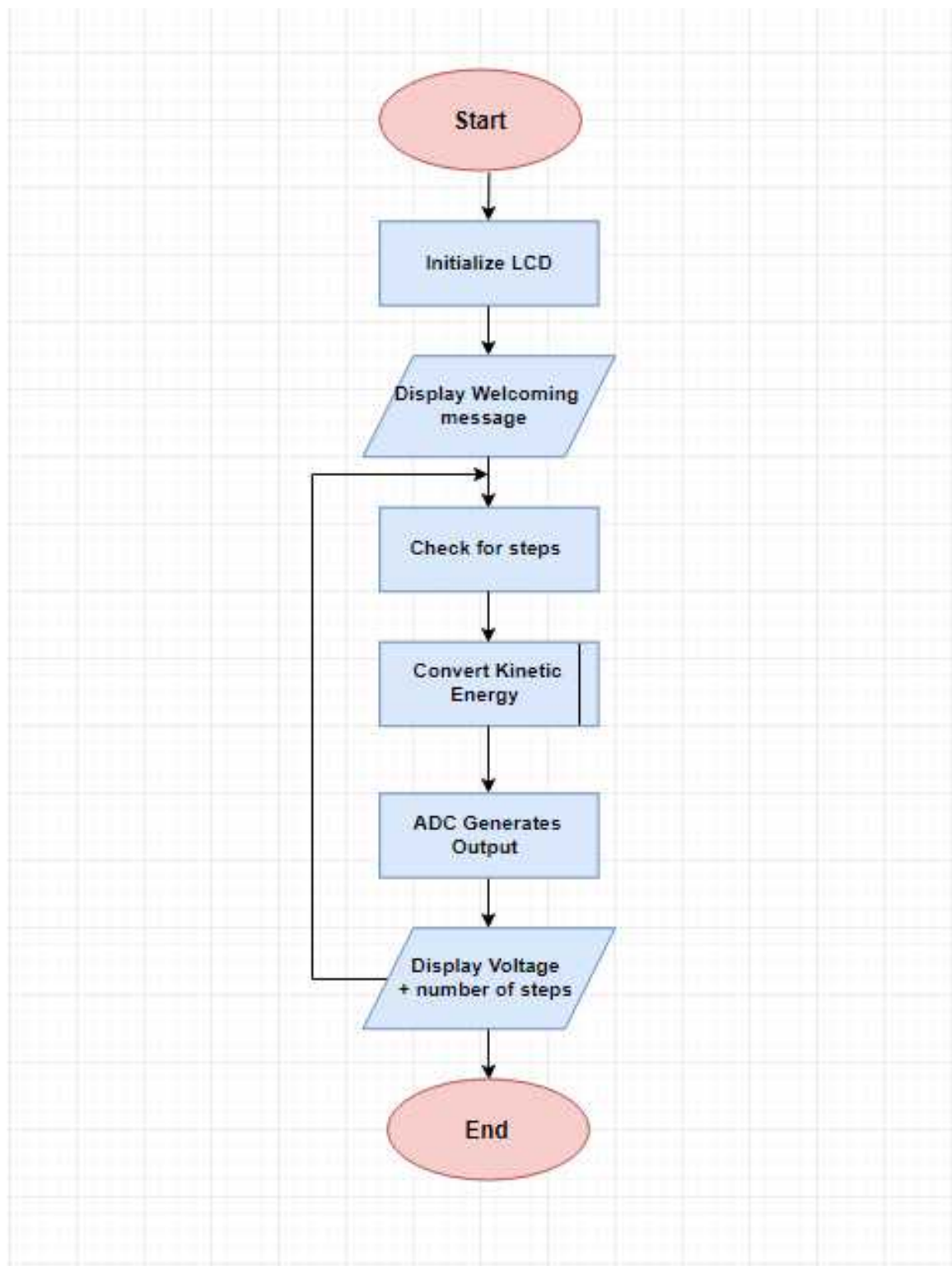

**Fig. 4.1 Flow chart**

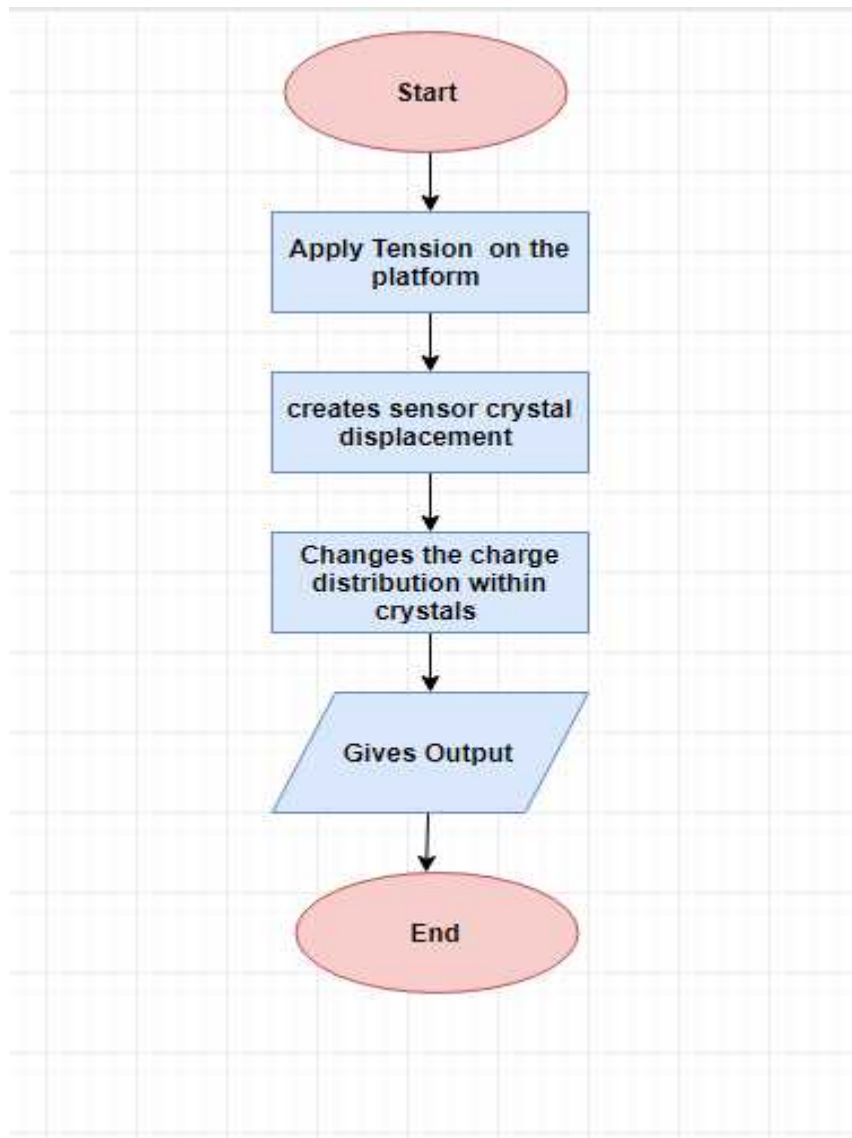

**Fig. 4.2 Kinetic energy conversion**

**The system steps shown in fig. 4.3:**

- When the system is “on” the LCD will be initialized and it will display a welcoming message for the users to let them know that the system is working which will be “footstep Power Generation “.
- When users start to use the path way, their footsteps will be used to generate a kinetic energy through the sensors then it would be filtered by capacitors, and current will be directed using diodes, then ADC start to take the AC output and convert it to DC one.
- The microcontroller will monitor the circuit to display on the LCD the voltage generated by steps and the number of them.

# 5 VALIDATION AND DISCUSSION

## 5.1 Description of the Implementation

- 1) The Footstep power generator works on the principle of piezoelectric effect.
- 2) Piezoelectric Effect is the ability of certain materials to generate an electric charge in response to applied mechanical stress.
- 3) Thus, squeeze certain sensors and you can make electricity flow through them.
- 4) In our project we have used the same phenomenon of producing piezoelectricity from piezoelectric crystal in the form of coin shaped disc.
- 5) When someone steps on the weighing machine the piezoelectric disc gets compressed. After the leg is lifted the sensor is decompressed.
- 6) Thus a full vibration is sensed by the sensor disc and a voltage across it is produced.
- 7) This voltage is displayed on its LCD.
- 8) Also, at the same time this voltage is used to charge the 12VDC Battery then charging a mobile phone.
- 9) LED's have been mounted under the weighing machine that is switched on whenever a voltage is generated.
- 10) This event is notified by a glowing LED on the PCB
- 11) Thus, whenever a person walks though the weighing machine the battery gets charged. This event is notified by glowing LED's beneath the weighing machine.

Generally, one step on our platform that contains 8Piezo sensors generates around 12V, noting that a capacitor of 370 $\mu$ F is used, the generated energy would be:

$$E = 1/2 \times C \times V^2 \quad [14]$$

$$E = \frac{1}{2} \times 370\mu F \times 144V = 0.03626J,$$

This is the energy generated of one step upon 8Piezo discs, which is a very small amount of energy. To give an idea to see how many steps our project would take to charge a cell phone battery of 12.16Wh:

$$E_j = P w \times t s \quad [15]$$

$$E = 12.16 \times 3600 = 43.776J, \text{ so:}$$

$$16.12Wh = 43.776J$$

So in order to charge the cell phone battery to its maximum storage capacity, the system needs to make  $\frac{43.776}{0.03626} = 1207$  steps.

## 5.2 Testing and Validation Results, Analysis and Discussion

This work here presents number of experiments for testing the Piezo sensors in different conditions with variable parameters to evaluate its performance and properties.

### 5.2.1 EXP1 output voltage of variable number of Piezo cells

#### Steps:

1. We have taken one Piezo plate and soldered 2 wires on its negative and positive sides.
2. Also we have connected a single diode on the positive end for the purpose of rectification (because the Piezo plate generates AC voltage and we need to convert it into DC).
3. We have connected the wires into a multimeter to measure the voltage.
4. We have applied some pressure on the plate and noticed the output voltage on the multimeter and filled up the result on a table (the output voltage varies with the pressure we applied on the plate).
5. For the other part of the experiment, we increased the number of Piezo plates starting from 2 plates to 4, and followed the same steps (connected the Piezo plates, wires, a bridge rectifier and the multimeter) to see how the amount of generated voltage would varies, and filled up the results in table 5.1.

#### Results:

**Table 5.1 Number of sensors VS O/P voltage**

Number of sensors	Output Voltage(V)
1	1.3
2	2.1

3	3.2
4	4.4

**Diagram:**

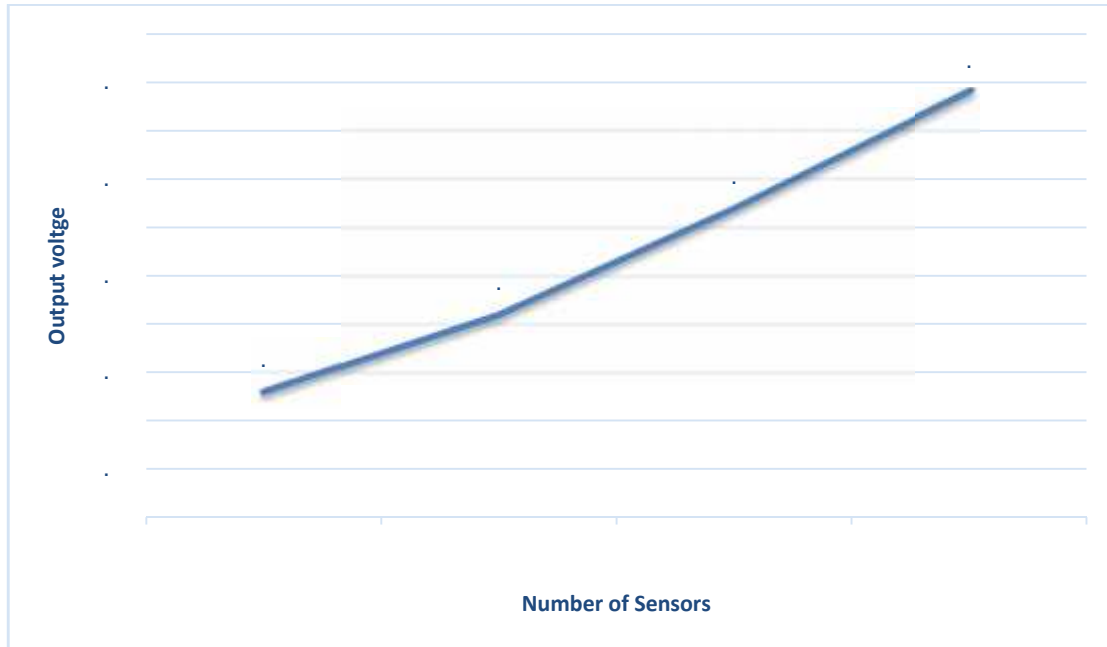
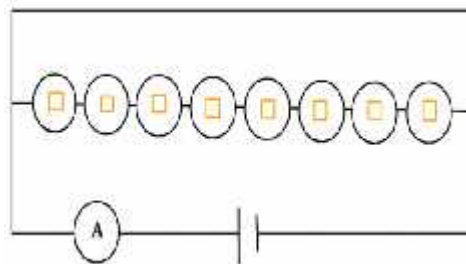

**Fig. 5.1** Number of sensors VS O/P voltage

**Discussion:**

As we can see from fig. 5.1, a **single** Piezo cell can generate voltage of 1V at least depending on the amount of the applied pressure. As we increased the number of sensors, the output voltage increased as well. As a result, we can increase the number of sensors to obtain increased power.

**5.2.2EXP2** output voltage and current of 8 Piezo cells connected in series and parallel



**Fig. 5.2** Series connection

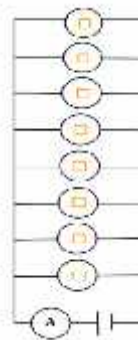

**Fig. 5.3** Parallel connection

### Steps:

1. We have taken a certain number of Piezo cells (**8 cells**), connected it in series as shown in fig. 5.2, and measured the output voltage across the cells using a multimeter (as we have done in experiment 1), noticed the result and filled up the results in table5.2.
2. For the same connection, we have connected the circuit into a load (resistor), measured the output current across the cells using the multimeter, noticed the result and filled up the results in table5.2.
3. For the other part of the experiment, we have used the same number of cells (**8 cells**), connected it in parallel as shown in fig. 5.3, and measured the output voltage and current across the cells and filled up the results in table 5.2.

### Results:

**Table 5.2 Connection type VS generated power**

Connection Type	Output Current(A)	Output Voltage(V)	Power(W)=V*I
Series	0.0015	8.4	0.0126
Parallel	0.0031	5.7	0.01767

### Discussion:

It can be noticed from table 5.2 that the voltage from a series connection is good but the current obtained is poor, whereas the current from a parallel connection is good but the voltage is poor, which is a problem we are going to solve in the next experiment.

**5.2.3 EXP3** output voltage and current of 8 Piezo cells connected in series-parallel connection

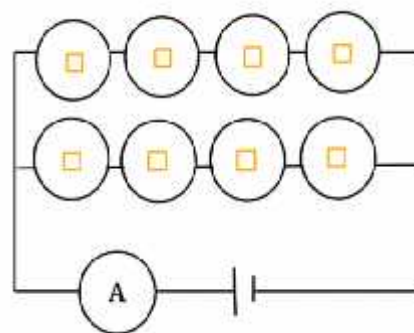

**Fig. 5.4 Series-Parallel connection**

**Steps:**

1. In this connection, we have connected 2 groups of 4 cells in series; these two groups are then connected in parallel as shown in fig. 5.4.
2. Measured the output voltage and current across the cells and filled up the results in table 5.3.

**Result:****Table 5.3 Series-Parallel connection VS generated power**

Connection Type	Output Current(A)	Output Voltage(V)	Power(W)=V*I
Series-Parallel	0.0044	14.5	0.0638

**Discussion:**

As we can see that a series-parallel connection is the right decision for a good voltage as well as current that can be obtained. Mathematically, for the EMF (Electromagnetic Force) of a cell we have:

$$E = V + Ir \quad [16]$$

$$Ir = E - V$$

$$r = (V - E)/I$$

$$r \propto \frac{1}{I}$$

Hence, we infer that higher the internal resistance of a cell, lower is its current flow capacity. Thus we connect the cells in parallel to reduce the total resistance to minimum.

**5.2.3 EXP4** output voltage of 8 Piezo cells with different weights**Steps:**

1. We had our friends with different weights walking on our platform to check the difference in the output voltage generated per each step and filled up the results in table 5.4

**Table 5.4 Weight VS O/P Voltage**

Weight(Kg)	Output Voltage(V)/Step
45	12.3
55	15.4
65	18.7
75	23.6

**Diagram:**

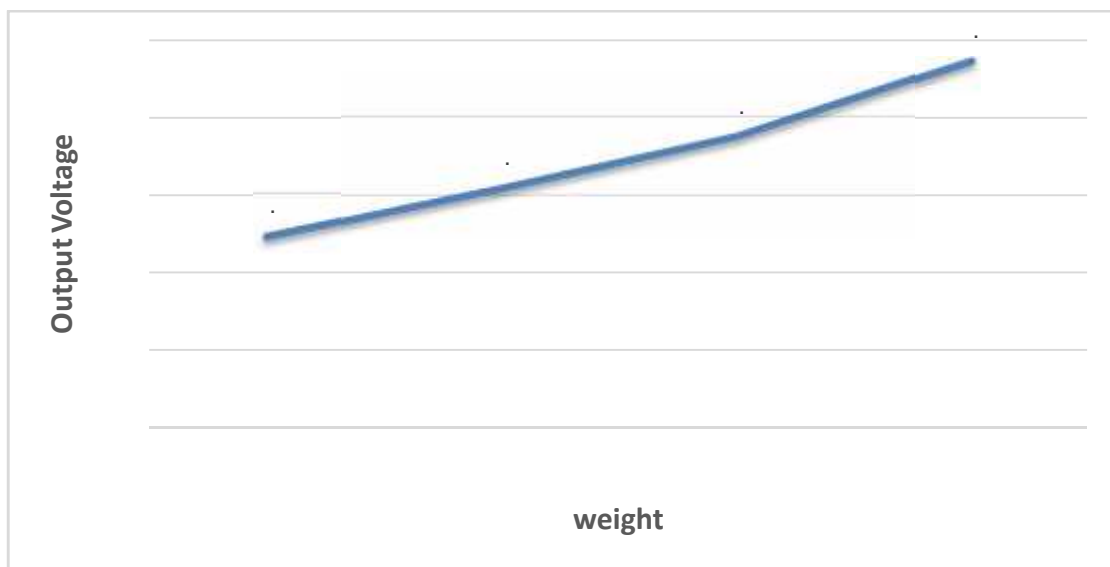

**Fig. 5.5 Weight VS O/P Voltage**

**Discussion:**

Depending on the observations shown in fig. 5.5, maximum voltage of 23.6V is generated across the cells when weight of 75Kg is applied on the platform.

### **5.3 Implementation Issues and Challenges:**

- We have used very sensitive electrical components which made it hard to deal with; multiple components have been replaced for multiple times due to short circuit that we faced during soldering.
- Soldering the PCB was not easy for us as beginners.
- Corrupted LCD Display Problem which has been solved by editing the pin numbers in code.



### **5.3 Methods used to validate the System**

We have done several experiments as we showed in section [5.2] for several times, filled up the results we have got in tables.

## **CONCLUSION**

A non-conventional, non-polluting energy is achieved when applying a force on piezoelectric sensors. These sensors are placed in such an arrangement so we can obtain the maximum output voltage; it converts a pressure into an electrical signal. These signals are then provided to the microcontroller based circuit.

As a result, installing this model in crowded places like malls and entries, where large numbers of people can step on, would generate more power, thus using this power to charge a connected battery by it. This model displays the charge generated on an LCD display, Also it consists of a USB mobile phone charging point to charge other devices.

Implementing this project can be considered as a solution of power crisis that faces our country.

As a future work, this principal can be applied in the speed breakers at high ways, where the vehicles rushes too much so ultimate power generated is obtained.

## REFERENCES

1. "Footstep Power Generation" by Vishwanil V. Sarnaik; Akshay P. Karnewar; Akshay S. Jidge; Tejas P. Pawar; GRD Journals- Global Research and Development Journal for Engineering | Volume 2 | Issue 7 | June 2017.
2. Footstep Power Generation system by Muhammad SherazKundi, Kamran Hayat, Muhammad Zeshan Haider .
3. "Footstep Power Generation system", YogeshMotey, PoojaDekate, MadhushriKewate, JayashreeAswale. International Journal of Innovations in Engineering and Science, Vol. 2, No.6, 2017.
4. " Foot Step Power Generation System" Ali Muhammad,aAsifAlib, SumeraBibic, Nadeem Ahmed Tuniod, 4th InternationalConference on Energy Environment and Sustainable Development 2016 (EESD 2016).
5. "Power Generation Footste" Sir Syed, Karachi, Pakistan, International Journal of Advancements in Research & Technology, Volume 3, Issue 4, April-2014.
6. Footstep Energy Generation By Piezoelectric Effect: A Case Study On New Delhi RailWay Station, International Journal of electronics & data communication.
7. Foot Step Power Generation Using Piezoelectric Material, MathaneNitashree V., SalunkheArati L, GaikwadSayali S, International Journal of Advanced Research in Electronics and Communication Engineering (IJARECE) Volume 4, Issue 10, October 2015.
8. Footstep Power Generation Using Piezo Electric Transducers, KiranBoby, Aleena Paul K, Anumol.C.V, Josnie Ann Thomas, Nimisha K.K., International Journal of Engineering and Innovative Technology (IJEIT) Volume 3, Issue 10, April 2014.
9. Proposed Method of Foot Step Power Generation Using Piezo Electric Sensor, Mr.A.Adhithan1, K.Vignesh, M.Manikandan, International Advanced Research Journal in Science, Engineering and TechnologyVol. 2, Issue 4, April 2015.
10. <https://learn.sparkfun.com/tutorials/diodes>.
11. [http://wiki.pinguino.cc/index.php/Pic18f2550\\_vs\\_atmega328](http://wiki.pinguino.cc/index.php/Pic18f2550_vs_atmega328).
12. Footstep Power Generation, GRD Journals- Global Research and Development Journal for Engineering | Volume 1 | Issue 5 | April 2016.
13. [https://en.wikipedia.org/wiki/Printed\\_circuit\\_board](https://en.wikipedia.org/wiki/Printed_circuit_board).

14. <http://hyperphysics.phy-astr.gsu.edu/hbase/electric/capeng2.html>.
15. <https://www.rapidtables.com/calc/electric/watt-to-kwh-calculator.html>.
16. <http://physicsnet.co.uk/a-level-physics-as-a2/current-electricity/electromotive-force-and-internal-resistanc>.

# Table of Contents

<b>1Introduction.....</b>	<b>1</b>
1.1Overview.....	1
1.2Motivation.....	1
1.3 Importance.....	1
1.4Aim.....	2
1.5System Description.....	2
1.6Problem Statement.....	3
1.7Problem Analysis.....	3
1.8System Requirements.....	3
1.9Expected Results.....	4
1.10Cost Calculation ted.....	4
<b>2Background.....</b>	<b>6</b>
2.1Theoretical Background.....	6
2.2LiteratureSurvey.....	6
2.3Description of the System Parts.....	6
2.4Design Constraints.....	7
<b>3Hardware Design.....</b>	<b>8</b>
3.1Methodology.....	8
3.2 Detailed Design.....	8
<b>4Software Design.....</b>	<b>13</b>

<b>5Validation and Discussion .....</b>	<b>15</b>
5.1Discription Of Implementation .....	15
5.2 Testing and Validation Results, Analysis and Discussion .....	16
5.3 Methods used to validate the System .....	21

## **5.2 Testing and Validation Results, Analysis and Discussion**

<b>Conclusion .....</b>	<b>22</b>
<b>References.....</b>	<b>23</b>

# List of Figures and Tables

<b>Fig.1.1</b> Description of the system .....	<b>2</b>
<b>Table 1.10</b> Components' cost .....	<b>4</b>
<b>Fig 3.1:</b> Block diagram .....	<b>8</b>
<b>Fig 3.2:</b> V-I graph of PVDF material .....	<b>9</b>
<b>Fig 3.3:</b> V-I graph of PZT.....	<b>9</b>
<b>Fig. 3.4</b> circuit diagram .....	<b>11</b>
<b>Fig. 3.5</b> User interface .....	<b>12</b>
<b>Fig. 4.1</b> Flow chart .....	<b>13</b>
<b>Fig. 4.2</b> Kinetic energy conversion.....	<b>14</b>
<b>Table 5.1</b> Number of sensors VS O/P voltage.....	<b>16</b>
<b>Fig. 5.1</b> Number of sensors VS O/P voltage .....	<b>17</b>
<b>Fig. 5.2</b> Series connection .....	<b>17</b>
<b>Fig. 5.3</b> Parallel connection .....	<b>17</b>
<b>Table 5.2</b> Connection type VS generated power .....	<b>18</b>
<b>Fig. 5.4</b> Series-Parallel connection.....	<b>18</b>
<b>Table 5.3</b> Series-Parallel connection VS generated power.....	<b>19</b>
<b>Table 5.4</b> Weight VS O/P Voltage .....	<b>20</b>
<b>Fig. 5.5</b> Weight VS O/P Voltage.....	<b>20</b>

