



# **Analysis of Fuel Cells Using COMSOL Multiphysics and Comparison Between Major Types of Fuel Cells SOFC and PEMFC**

By

Abed Al-Hadee Nassar

Obaida Abu Saleh

Supervisor:

Dr. Diya Arafah

Submitted to the College of Engineering  
in partial fulfillment of the requirements for the degree of  
Bachelor degree in Automotive Engineering

Palestine Polytechnic University

December 2015

## Abstract

The main purpose of the present study is the use of COMSOL Multiphysics software in the analysis of fuel cells. Two types of fuel cells are considered: Solid Oxide Fuel Cell (SOFC), and Proton Exchange Membrane Fuel Cell (PEMFC) as they are the most promising types.

The use of Comsol Multiphysics software in the modeling of fuel cells is due to the multiphysics (electrical, thermal, chemical) approach available in the software.

Finally, based on the simulation results obtained some comparison will be provided between SOFC and PEMFC.

## المخلص

الهدف الرئيسي من الدراسة الحالية هو استخدام برنامج (COMSOL Multiphysics) في تحليل خلايا الوقود، نوعين من خلايا الوقود وهما خلية الوقود ذات غشاء الأوكسيد الصلب (SOFC) و خلية الوقود ذات غشاء تبادل البروتون (PEMFC)، حيث ان هذين النوعين هما من أكثر الانواع الواعدة في المستقبل.

سيتم استخدام برنامج (COMSOL Multiphysics) لتحليل خلايا الوقود باستخدام الحاسوب وذلك نظرا لمقدرته على دراسة خلايا الوقود من النواحي الكهربائية والحرارية والكيميائية.

وفي النهاية بناء على نتائج الدراسة الحالية سيتم عمل بعض المقارنات بين النوعين المذكورين.

## List of Figures

Figure Number	Figure Name	Page Number
Figure 1.1	Distribution of the world oil and natural-gas consumption, production and reserves	3
Figure 1.2	CO2 global records	4
Figure 1.3	Distribution of CO2 in the world	5
Figure 1.4	Percentages of Greenhouse Gases in the atmosphere	6
Figure 2.1	Individual fuel cell	11
Figure 2.2	Planar design	12
Figure 2.3	Tubular design	12
Figure 2.4	shows the three classifications of Fuel Cells	18
Figure 2.5	show the mechanical-support layer classifications	19
Figure 3.1	Comsol Multiphysics interface	24
Figure 3.2	Comsol Multiphysics simulation types	25
Figure 3.3	Comsol Multiphysics Model Window	27
Figure 3.4	Comsol Multiphysics Definition Window	28
Figure 3.5	Comsol Multiphysics Geometry Window	29
Figure 3.6	Comsol Multiphysics Materials Window	30
Figure 3.7	Comsol Multiphysics Materials Library	30
Figure 3.8	Comsol Multiphysics Physics Window	31
Figure 3.9	Comsol Multiphysics Mesh Window	32
Figure 3.10	Comsol Multiphysics Study Window	33
Figure 3.11	Comsol Multiphysics Results Window	34
Figure 4.1	New Window	36
Figure 4.2	Select Space Dimension Window	37
Figure 4.3	Select Physics Window (1)	37
Figure 4.4	Select Physics Window (2)	38
Figure 4.5	Select Physics Window (3)	40
Figure 4.6	Select Study Window	41
Figure 4.7	Loading Parameters Windows	42
Figure 4.8	Loading Work Plane 1 Windows	43
Figure 4.9	Loading Rectangle 1 Windows	44
Figure 4.10	Fuel Cell Blocks	46
Figure 4.11	Fuel Cell shape	47
Figure 4.12	Making explicit in Definition Window	48
Figure 4.13	Making boundary probe in Definition Window	50
Figure 4.14	Making Secondary Current Distribution (siec) in Model Builder window	51
Figure 4.15	Making Porous Electrode in Model Builder window	52
Figure 4.16	Making Porous Electrode Reaction	54
Figure 4.17	Making Electric Ground	56
Figure 4.18	Making Electric Potential	57
Figure 4.19	Putting Initial values	58

Figure 4.20	making Transport of Concentrated Species -Cathode	59
Figure 4.21	making Convection and Diffusion	60
Figure 4.22	making Porous Electrode Coupling	62
Figure 4.23	making Reaction Coefficients	63
Figure 4.24	making Inflow	64
Figure 4.25	making Inflow	68
Figure 4.26	making Fluid Properties	69
Figure 4.27	making Porous Matrix Properties	70
Figure 4.28	making Porous Electrode Coupling	71
Figure 4.29	making Reaction Coefficients	72
Figure 4.30	making Wall	73
Figure 4.31	making Edge	76
Figure 4.32	making size	77
Figure 4.33	making Mapped	78
Figure 4.34	making Distribution	79
Figure 4.35	making Mapped Build Selected	80
Figure 4.36	making Swept	81
Figure 4.37	making Size	82
Figure 4.38	making Size Stationary	83
Figure 4.39	making Study	84
Figure 4.40	making Compute Study	85
Figure 4.41	Oxygen mole fraction in the gas channel and in the gas diffusion cathode while operating at a cell voltage of 0.5V	86
Figure 4.42	Hydrogen distribution in the anode at 0.5 V cell voltage	87
Figure 4.43	shows the voltage as a function of the total current (polarization curve)	88
Figure 4.44	shows the power output as a function of the cell voltage. The model predicts a maximum power-output of 940W/m <sup>2</sup> for the unit cell	90
Figure 4.45	The current density in the unit cell operating at 0.5 V. The cathode inlet is to the right	91
Figure 4.46	The Electrolyte current density in the unit cell operating at 0.5 V	93
Figure 5.1	New Window	95
Figure 5.2	Select Space Dimension Window	96
Figure 5.3	Select Physics Window (1)	96
Figure 5.4	Select Physics Window (2)	97
Figure 5.5	Select Physics Window (3)	98
Figure 5.6	Select Study Window	99
Figure 5.7	Loading Parameters Windows	100
Figure 5.8	Drawing Blocks in Geometry Window	101
Figure 5.9	Fuel Cell Blocks and shape	102
Figure 5.10	Making explicit in Definition Window	103
Figure 5.11	Making All explicit in Model Builder Tree	103
Figure 5.12	Making Union(1) in Definition Window	104
Figure 5.13	Making Union(2) in Definition Window	105

Figure 5.14	Making Porous Electrode in Physics Window	106
Figure 5.15	Making Porous Electrode Reaction	107
Figure 5.16	Making Electrode	108
Figure 5.17	Making Electric Ground	109
Figure 5.18	Making Electric Potential	110
Figure 5.19	Putting Initial values	110
Figure 5.20	Making Reacting Flow in Porous Media	111
Figure 5.21	Making Porous Matrix Properties	112
Figure 5.22	Making Inflow & Outflow & Inlet & Outlet & Symmetry Reacting Flow In Porous Media (1)	114
Figure 5.23	Making Inflow & Outflow & Inlet & Outlet & Symmetry Reacting Flow In Porous Media (2)	115
Figure 5.24	Adding Mesh in Mesh Window	116
Figure 5.25	Adding Edge & Distribution in Mesh	117
Figure 5.26	Edge & Distribution & Mapped & Swept in Mesh	119
Figure 5.27	Making Domain Probe Definition in Model Builder Tree	120
Figure 5.28	Adding & Making & Computing Study	121
Figure 5.29	Polarization plot	122
Figure 5.30	Ionic current in the polymer membrane at 0.4 V	123
Figure 5.31	Result Window components	125
Figure 5.32	oxygen concentration at the cathode (bottom) in the cell at 0.4 V	126
Figure 5.33	Hydrogen concentration at the anode (top) in the cell at 0.4 V	127
Figure 5.34	Water concentration on the anode (top) in the cell at 0.4 V	129
Figure 5.35	Water concentration on the cathode (bottom) in the cell at 0.4 V	130
Figure 6.1	PEMFC Model Geometry	133
Figure 6.2	SOFC Model Geometry	134
Figure 6.3	PEMFC Polarization Curve	135
Figure 6.4	SOFC Polarization Curve	135
Figure 6.5	PEMFC Oxygen Concentration at The Cathode (Bottom)	136
Figure 6.6	SOFC Oxygen Mole Fraction in The Cathode (Top)	137
Figure 6.7	PEM Hydrogen Concentration at The Anode (Top)	138
Figure 6.8	SOFC Hydrogen Mole Fraction in The Anode (Bottom)	139

## Table of Contents

Cover Page .....	I
Abstract.....	II
List of figures .....	III
Table of contents .....	V

### Chapter One

1.1 Background .....	2
1.2 Project motivation .....	7
1.3 Aims and Objectives.....	8
1.4 Methodology .....	8
1.5 Significance of study .....	8
1.6 Project scope .....	9

### Chapter Two

2.1 Introduction .....	11
2.2 Fuel Cell Structure .....	13
2.3 Fuel Cell Types .....	16
2.4 Fuel Cell operating principle .....	17
2.5 Fuel Cell designs .....	18

2.6 Safety Precautions .....	21
2.7 Previous Studies .....	22

### Chapter Three

3.1 Introduction .....	24
3.2 Comsol Multiphysics .....	24
3.3 The Batteries & Fuel Cells Module .....	26
3.4 Comsol Multiphysics steps: .....	26
Step 1. Model .....	27
Step 2. Definitions .....	28
Step 3. Geometry .....	29
Step 4. Materials .....	30
Step 5. Physics .....	31
Step 6. Mesh .....	32
Step 7. Study .....	33
Step 8. Results .....	34

### Chapter Four

4.1 Model .....	36
4.2 Definitions .....	42
4.3 Geometry .....	43
4.3.1 Definitions .....	48
4.4 Physics .....	51
4.4.1 Secondary Current Distribution (Siec) .....	51
4.4.2 Transport of Concentrated Species (Tcs) .....	59
4.4.3 Transport of Concentrated Species 2 (Tcs2) .....	65

4.4.4 Free and Porous Media Flow (Fp) .....	67
4.4.5 Free and Porous Media Flow 2 (Fp2) .....	73
4.5 Mesh .....	76
4.6 Study .....	83
4.7 Results .....	86

## **Chapter Five**

5.1 Model .....	95
5.2 Definitions .....	100
5.3 Geometry .....	101
5.4 Physics .....	106
5.5 Mesh .....	116
5.6 Study .....	121
5.7 Results .....	122

## **Chapter six**

6.1 Introduction .....	132
6.2 Model Geometry .....	133
6.3 Polarization Curve .....	135
6.5 Oxygen in The Fuel Cell .....	136
6.5 Hydrogen in The Fuel Cell .....	137
6.6 Recommendations .....	140
References.....	141



# **Chapter 1**

## **Introduction**

---

**1.1 Background**

**1.2 Project motivation**

**1.3 Aims and Objectives**

**1.4 Methodology**

**1.5 Significance of study**

**1.6 Project scope**

## 1.1 Background

Our world is facing an inevitable problem which is growing more and more and has become a great issue, this problem is the supply of energy resources. One of the major causes of this problem is the increasing number of people thus increasing the demand for energy. In future this might lead to energy crisis.

Globally speaking, demography and its impact on both economic growth and development affect the size and pattern of energy demand. World primary energy demand is projected to rise by 1.5% per year between 2007 and 2030, an overall increase of 40%, the latest projections indicate that the global population will grow from an estimated 6.6 billion in 2007 to 8.2 billion in 2030, i.e. 1% per year on average. Most of the increase in global population will occur mainly in Asia and Africa. Africa will experience the fastest rate of growth, about 2%, followed by the Middle East countries with an annual rate of 1.6%. China, growing at a rate of 0.4%, will remain the world most populated country with 1.46 billion people in 2030, whereas the population in India, growing faster (1, 1%), will almost reach that of China by then. The population in North America is expected to increase on average by 0.8%, while it will increase slightly in Europe and even fall in Japan [1].

Such information emphasizes engineers to seek for better energy sources as a major issue to solve, since the world energy supply is based on combustion technologies of fossil fuels, which are non-renewable, distributed and in addition of being the one of the biggest causes of pollution Fossil-fuels reserves are limited and confined to a few regions in the world.

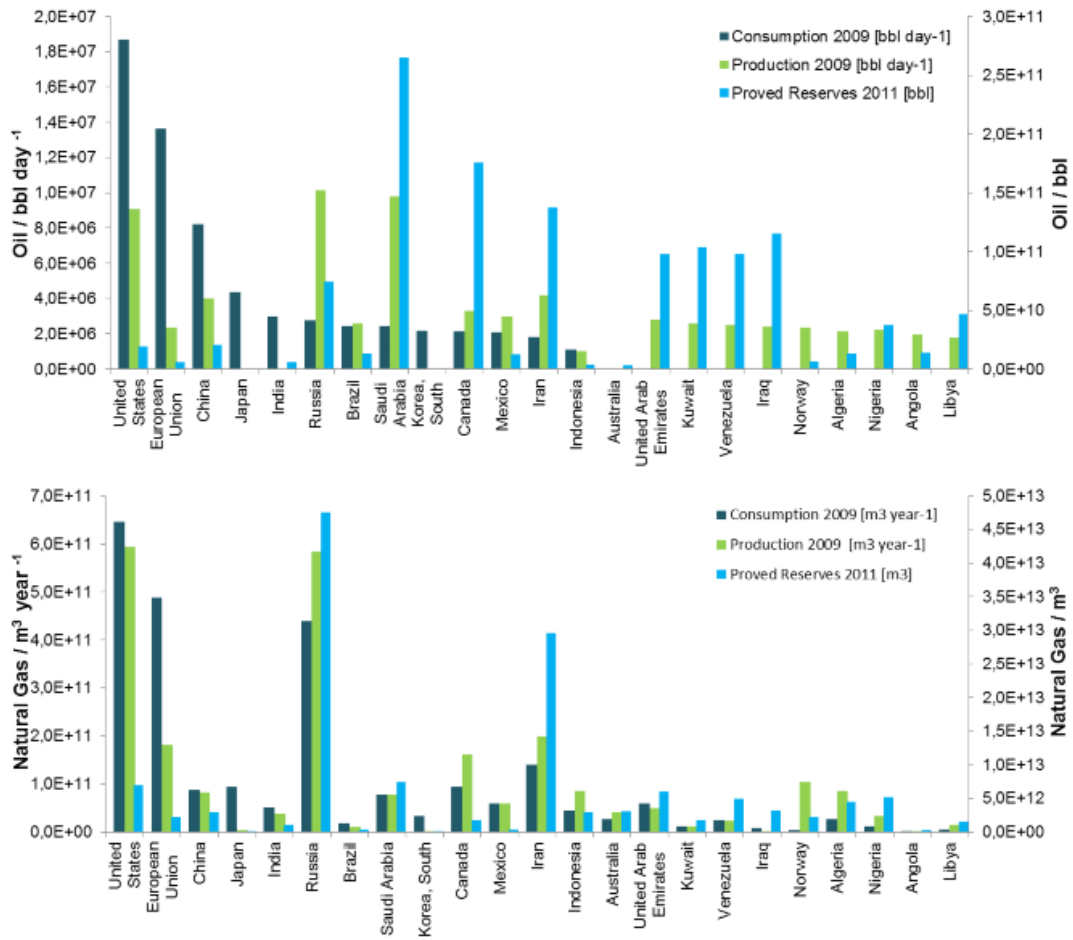

Figure 1.1 Distribution of the world oil and natural-gas consumption, production and reserves [2]

Figure 1.1 shows the proved reserves, production and consumption rates of oil and natural gas throughout the world. Moreover, the emissions from fossil-fuel combustion are suspected to have a massive impact on the environment.

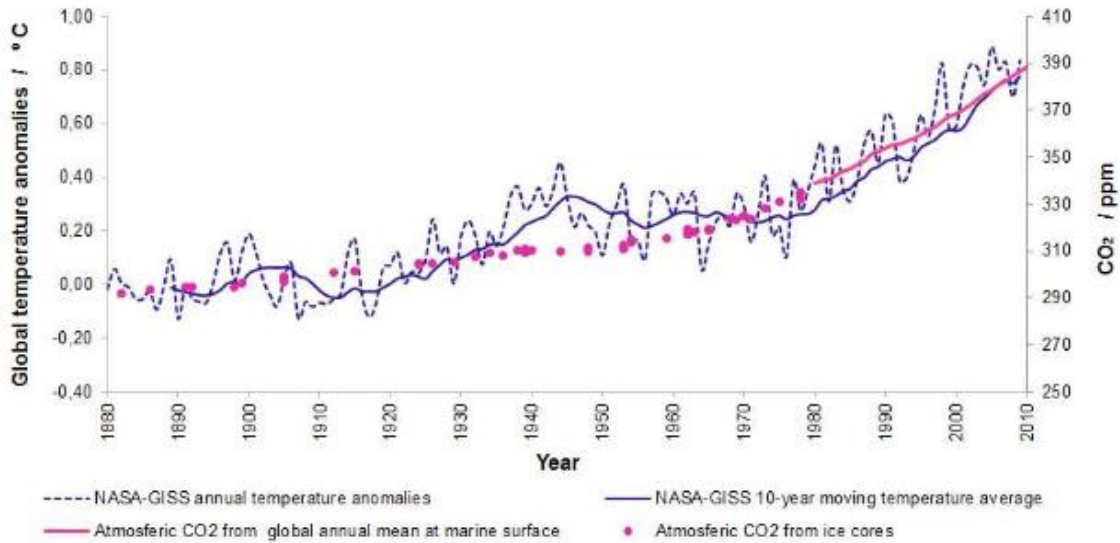

Figure 1.2 CO<sub>2</sub> global records [3]

In figure 1.2 Left y-axis shows the anomalies of the global (land-ocean) mean temperature relative to the base period 1880-1899, from NASA's GISS data [3, 4]. Right axis shows the historical atmospheric CO<sub>2</sub> records from both globally.

One of the products of the combustion reaction is carbon dioxide, a greenhouse gas (GHG), that strongly absorbs the infrared and near infrared radiation. The intensive combustion of fossil fuels in the last decades has caused an increase of the CO<sub>2</sub> in the atmosphere. Figure 1.3 shows the countries responsible for CO<sub>2</sub> emissions.

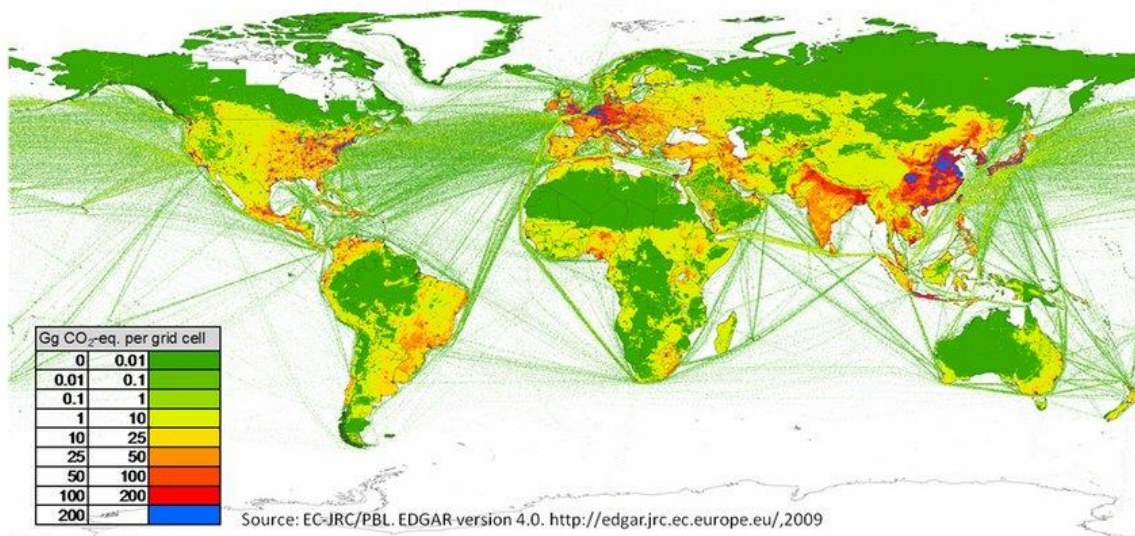

Figure 1.3 Distribution of CO<sub>2</sub> in the world [5]

Greenhouse gases comprise less than 1% of the atmosphere. Their levels are determined by a balance between “sources” and “sinks”. Sources and sinks are processes that generate and destroy greenhouse gases respectively. Human affect greenhouse gas levels by introducing new sources or by interfering with natural sinks.

The major greenhouse gases in the atmosphere are carbon dioxide (CO<sub>2</sub>), methane, (CH<sub>4</sub>), nitrous oxide (N<sub>2</sub>O), chlorofluorocarbons (CFCs) and Ozone (O<sub>3</sub>). Atmospheric water vapor (H<sub>2</sub>O) also makes a large contribution to the natural greenhouse effect but it is thought a large contribution to the natural greenhouse effect but it is thought that its presence is not directly affected by human activity. Percentages of greenhouse gases are shown in the figure below [6].

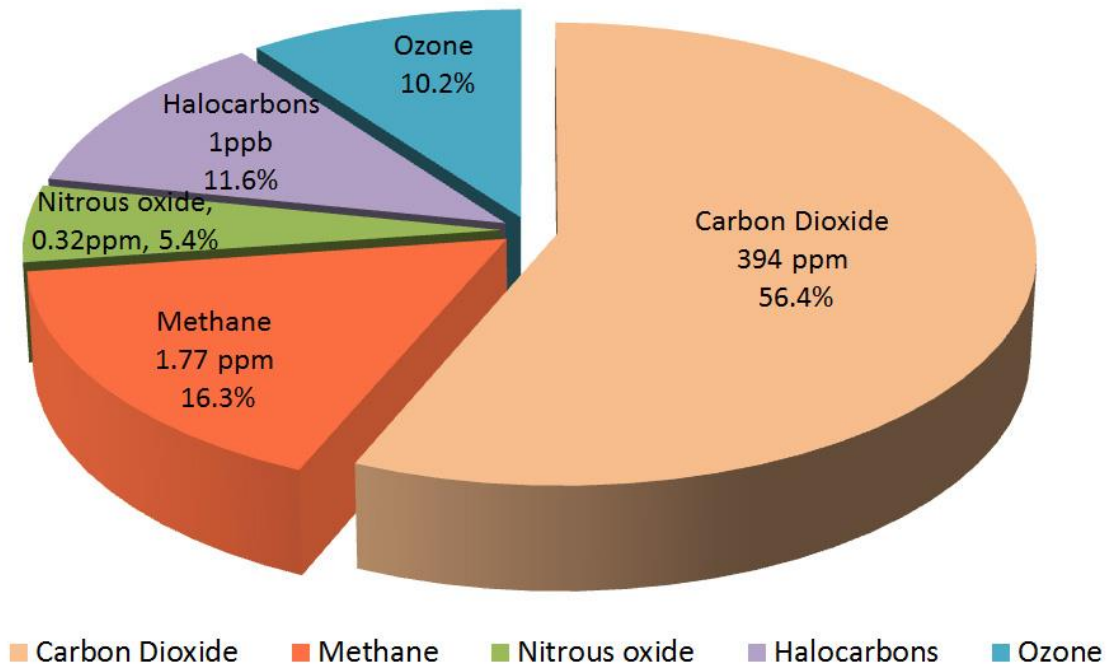

Figure 1.4 Percentages of Greenhouse Gases in the atmosphere [7]

In view of the environmental concerns of the fossil-fuel energy, as mentioned above, vulnerable countries have questioned their 20th-century energy policy and have started investing in the development of cleaner and renewable energies to meet their growing energy demand [8]. In 2007 the EU set the basis for a new European Energy Policy aimed at:

- a) Combating the climate change;
- b) Limiting the EU vulnerability to the imported hydrocarbons;
- c) Promoting economic growth by providing secure and affordable energy to consumers.

The targets of the new policy by 2020 are:

- (i) 20% reduction of the greenhouse gas emissions;
- (ii) 20% increase of the renewable-energy share

- (iii) 20% improvement in energy efficiency. To meet these targets, the EU is leading the development of cleaner, more efficient and hydrocarbon- independent energy- systems, as it is the case of the fuel cells.

To achieve this goal, a major effort has to be made to improve efficiency of present- day energy- systems and to find alternative, cleaner energy- sources. An example of cleaner energy sources is fuel cell.

A fuel cell is a device that converts the chemical energy from a fuel into electricity through a chemical reaction with oxygen or another oxidizing agent. It has many types such as Solid Oxide Fuel Cell, Proton Exchange Membrane Fuel Cell, and Molten Carbonate Fuel Cell. These fuel cells are very promising energy sources as they are considered to be almost clean. In the present project, the Analysis of Fuel Cells using Comsol Multiphysics and comparison between major types of fuel cells SOFC and PEM.

## **1.2 Project motivation**

The project will focus on the main types of fuel cells Solid Oxide Fuel Cell (SOFC) and Proton Exchange Membrane Fuel Cell (PEMFC) and make some comparison between them and conclude which is the best to use in the applications because each of them have some advantages and some disadvantages at the last of project and comparison the decide one of them to say this is accurate more than other.

### **1.3 Aims and Objectives**

In this project, we are going to seek for the parameters that affect the performance of an SOFC and PEMFC, the effects of manipulate them and to seek for the values that might lead to a better performance in order to achieve the best efficiency.

The goal of using simulation programs is the need for a model that accurately depicts what happens in the real world.

### **1.4 Methodology**

A simulation software, basically Comsol Multiphysics, is going to be used to create a model for the SOFC and PEMFC, this allows us to predict how the changes in the parameters would create difference on real life, in addition to the comparison between two models of different cells SOFC and PEMFC.

### **1.5 Significance of Study**

With regard to the main aim of the project considering comparing between the SOFC and PEMFC efficiencies, the knowledge of the operating conditions that determine the cell performance (such as the distribution of species concentration, current density or temperature) is difficult to acquire experimentally.



## 1.6 Project scope

The time table for the first semester is illustrated in Table 1.1.

TASKS	1 <sup>st</sup> Month				2 <sup>nd</sup> Month				3 <sup>rd</sup> Month				4 <sup>th</sup> Month			
	W <sub>1</sub>	W <sub>2</sub>	W <sub>3</sub>	W <sub>4</sub>	W <sub>1</sub>	W <sub>2</sub>	W <sub>3</sub>	W <sub>4</sub>	W <sub>1</sub>	W <sub>2</sub>	W <sub>3</sub>	W <sub>4</sub>	W <sub>1</sub>	W <sub>2</sub>	W <sub>3</sub>	W <sub>4</sub>
Identification of Project Idea	■	■														
Installing consol multiphysics program			■	■												
Training on the simulation program				■	■	■	■	■	■	■	■	■				
Establishing Scientific Background					■	■	■									
Documentation of Literature Review						■	■	■								
Choosing Suitable Requirements for Implementation								■	■	■	■					
Writing First draft Report									■	■	■	■	■	■	■	
Presentation of project																■

Table 1.1 time table for the first semester

## **Chapter 2**

### **Literature review**

---

- 2.8 Introduction**
- 2.9 Fuel Cell Structure**
- 2.10 Fuel Cell Types**
- 2.11 Fuel Cell operating principle**
- 2.12 Fuel Cell designs**
- 2.13 Safety Precautions**
- 2.14 Previous Studies**

## 2.1 Introduction

Fuel cell is an energy conversion unit that converts a gaseous fuel to electrical energy and heat by electrochemical combination of a fuel with an oxidant. Since it is operated electrochemically and is not limited by the Carnot cycle, lower emissions such as NO are produced from fuel cells compared to the cleanest combustion process. Due to its high conversion efficiency and environmental acceptability, the fuel cell is regarded as an effective process to produce electricity from chemical components. Moreover, this technology also presents flexibility and modularity, as it does not suffer appreciably from problems of lubrication, wear, leakage and heat loss, which affect the reliability of traditional heat engines. [9]

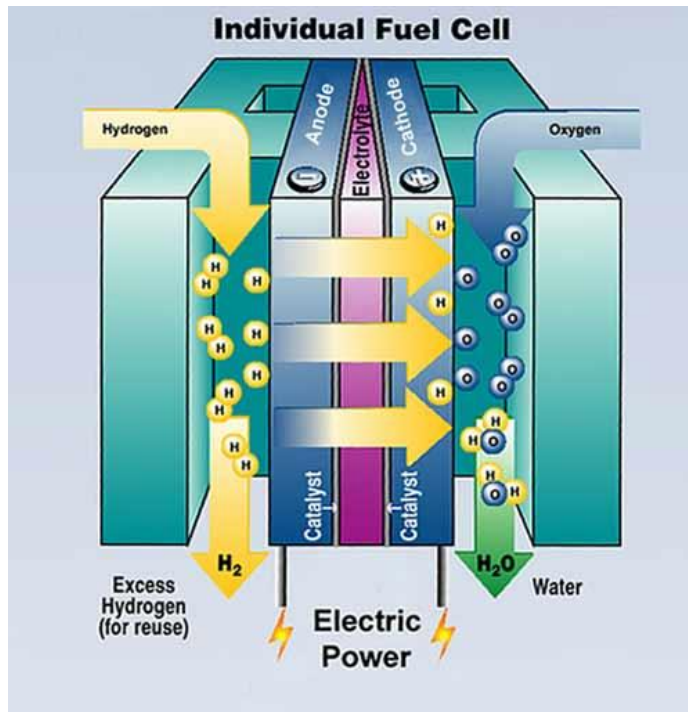

Figure 2.1 Individual fuel cell [11]

Unlike conventional engines, fuel cells do not burn the fuel to run pistons or shafts, and so have fewer sources of efficiency loss, low emissions and no moving parts. Unlike batteries, a fuel cell does not run down or require recharging, but it operates as long as both fuel and oxidant are supplied.

The following figures show how fuel cells are put in rows to form a stack for both planar and tubular designs.

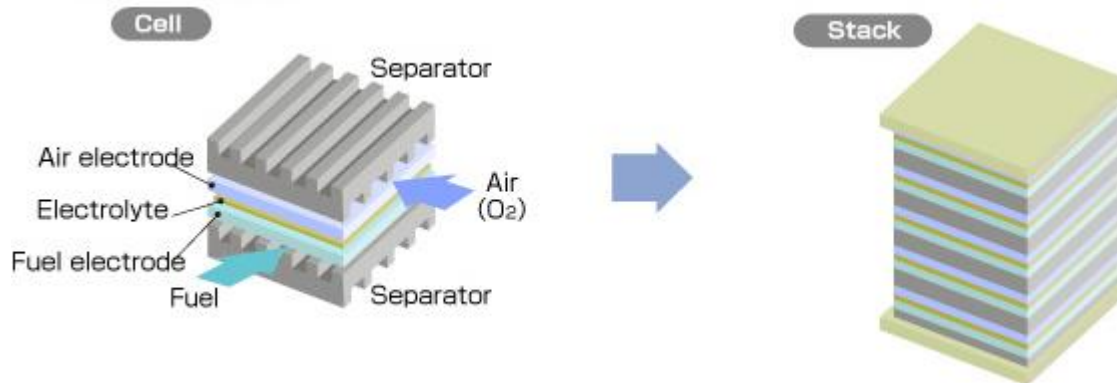

Figure 2.2 Planar design [12]

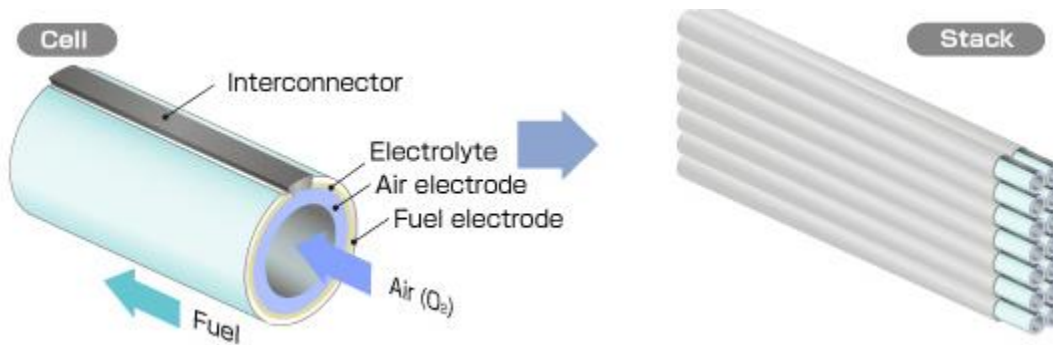

Figure 2.3 Tubular design [13]

Fuel cells offer a unique combination of advantages, in terms of:

- Energy efficiency: fuel cells are amongst the most efficient energy conversion devices. Moreover, they can be exploited in a wide range of applications due to their flexible operation, i.e. They can be used solely or in hybrid systems; they can use a variety of fuels, and can be applied for stationary, transport and portable applications.
- Environment: fuel cells can help significantly reduce greenhouse gas emissions and urban pollution, and improve air quality. Fuel cells provide emission free mobility, near zero emissions, zero when using clean hydrogen and low emissions when using other fuels. They are mechanically simple, implying low maintenance requirements and low vibration thus being very useful in areas where noise pollution is undesirable.

- Energy security: fuel cells and hydrogen can support the development of decentralized structures building upon regionally available energy sources. This in return will reduce oil or gas imports, and at the same time it will meet the citizen's needs in terms of power stability and predictability, they have Fuel flexibility (depending on the cell type) which gives a wider range of fuel use.

## 2.2 Fuel Cell Structure

Typically, a single fuel cell consists of three main sections: anode, electrolyte and cathode. A fuel and an oxidant, supplied from external sources, are introduced to the anode and cathode side, respectively. Both could be any gases capable of being electrochemically oxidized and reduced. The driving force of the operation is the chemical potential gradient of ions across the electrolyte. Direct-current electricity was consequently produced in the external circuit. In the real application, fuel cells are connected in a series of cells in order to obtain higher outlet voltage. An interconnect plate is always installed to provide the electronic contact between the anode of one cell and the cathode of the next cell. In this section, the Fuel Cell components will be discussed. [10]

### 2.2.1 Electrolyte

Is a main component of Fuel Cell. It may carry either oxide-ion( $O^{2-}$ ) or proton ( $H^+$ ). However, there are the required properties of the oxides for using as Fuel Cell electrolyte materials

For optimum cell performance, the electrolyte has to meet the following requirements

- High oxide ion (or proton) conductivity ( $0.01-0.1 \text{ S cm}^{-1}$  for the thickness
- (1-100 $\mu\text{m}$ .) Low oxide ion conductivity resulting higher Ohmic loss.
- Low electronic conductivity: Higher electronic conduction causes higher voltage loss and oxygen leakage without producing electricity.
- Chemical stability: They should have the stability either in the thermal stability in air and fuel and stability under the oxygen potential gradient.

- Mechanical strength (Stress)
- Low cost for both of raw materials and the processing.

## 2.2.2 Electrode

The electrode of Fuel Cell consists of 2 parts: anode and cathode. Details of each type of electrode are given below [10]. General properties of electrodes are:

- Catalytic activity (for oxygen dissociation and incorporation reactions in cathode and for electrochemical oxidation of H or CO and others fuel processing in anode)
- Electronic (preferable: ionic) conductivity (electrode conductivity should be higher than  $10 \text{ S cm}^{-1}$ )
- Chemical Stability and compatibility
- High morphological stability without sintering
- Mechanical compatibility with the other materials; electrolyte and Interconnect; thermal expansion mismatch may cause the breakdown of the cell.
- Low cost

### 2.2.2.1 Cathode

The air electrode operates in an oxidizing environment of air or oxygen at high temperatures and participates in the oxygen reduction reaction so it should have the following properties:

- High electronic conductivity.
- Chemical and dimensional stability in the oxidizing environment encountered during cell operation.
- Thermal-expansion properties matching the other cell components.
- Compatibility and minimum reactivity with the electrolyte and the interconnection with which air electrode comes into contact.
- Sufficient porosity to facilitate the transport of molecular oxygen from the gas phase to the air electrode/electrolyte interface.

### **2.2.2.2 Anode**

The fuel electrode operates at high temperatures in the reducing environment of the fuel chamber and catalyzes the oxidation reaction of the fuel. A good material for the anode has to exhibit the following characteristics:

- High electronic conductivity.
- Stability in the reducing environment of the fuel.
- Thermal-expansion properties matching the other cell components.
- Compatibility and minimum reactivity with the electrolyte and the interconnection with which fuel electrode comes into contact.
- Sufficient porosity to allow for the transport of the fuel to and the transport of the products away from the electrolyte/fuel electrode interface where the fuel oxidation reaction takes place.

### **2.2.3 Interconnects**

The interconnect material is in contact with both electrodes, thus it must be stable in both oxidizing and reducing atmospheres. Furthermore, it must be an electronic conductor and have similar characteristics to that of electrolyte. In addition to chemical compatibility, the coefficient of thermal expansion must be matched with the other cell components to avoid the generation of stress at the operating condition. Materials and fabrication cost are also

The requirements of the interconnects are the most severe of all cell components, since they are exposed to both fuel and air atmospheres:

- Nearly 100% electronic conductivity.
- Stability in both oxidizing and reducing atmospheres at the cell operating- temperature since it is exposed to air (or oxygen) on one side and fuel on the other.
- Low permeability for oxygen and hydrogen to minimize direct combination of oxidant and fuel during cell operation in planar designs.
- A thermal expansion coefficient close to that of the other cell materials.
- Non-reactivity with other cell materials.

## 2.2.4 Sealant

The sealants need to fulfill all the criteria for all of components. They must be stable in a wide range of oxygen partial pressure (air and fuel) while minimizing thermal stresses during high-temperature operation.

The quality of seals must be high, since even small leaks in these seals can affect the cell potential, resulting in the reduction of performance. Sealant development is additionally complicated because the optimal sealant depends on the materials of other components.

## 2.3 Fuel cells types

- The Solid Oxide Fuel Cell (SOFC) employs a solid electrolyte, made of a solid oxide that at high temperatures ( $T \approx 800^\circ\text{C}$ ) conducts oxide ions ( $\text{O}^{2-}$ ) from the cathode to the anode. The SOFC development can be traced back to 1899 when Nernst was the first to describe zirconia ( $\text{ZrO}_2$ ) as an oxygen-ion conductor.
- The Proton Exchange Membrane Fuel Cell (PEMFC) uses a membrane that conducts protons ( $\text{H}^+$ ) from the anode to the cathode (at  $T \approx 80^\circ\text{C}$ ). The invention of the polymeric membrane, by T. Grubb (1955) and L. Niedrach (1958), allowed the development of this technology in the mid- sixties.
- The Alkaline Fuel Cell (AFC) has an electrolyte composed of a molten alkaline mixture of potassium hydroxide (KOH at  $T \approx 100^\circ\text{C}$ ), that conducts hydroxide ions ( $\text{OH}^-$ ) from the cathode to the anode. The AFC was first introduced by Thomas Francis Bacon in 1933.
- The Molten Carbonate Fuel Cell (MCFC) uses a high temperature ( $T \approx 650^\circ\text{C}$ ) mixture of carbonates, within which carbonate ions ( $\text{CO}_3^{2-}$ ) circulate from the cathode to the anode. The origin of molten carbonate fuel cells lies in other cells such as solid oxide. H.J. Borers and J.A.A. Ketelaar were the first to prove its functionality in 1960.
- The Phosphoric Acid Fuel Cell (PAFC) was first made by Elmore and Tanner in 1961. The electrolyte of the PAFC is formed of liquid phosphoric acid that conducts hydrogen ions ( $\text{H}^+$ ) from the anode to the cathode (at  $T \approx 200^\circ\text{C}$ ).
- The Direct Methanol Fuel Cell (DMFC) uses a polymeric membrane as Electrolyte, similar to that of the PEMFC, which drives hydrogen ions ( $\text{H}^+$ ) from the anode to the cathode (at  $T \approx 60^\circ\text{C}$ ). This technology was introduced in 1990 by Jet Propulsion Laboratory of NASA in conjunction with the University of Southern California.



Fuel cells can be further classified according to their operating temperature. Hence, it is often distinguished between low-temperature fuel cells (PEMFC, DMFC, AFC and PAFC) and high-temperature fuel cells (MCFC and SOFC).

In the recent years, the greatest research interest throughout the world has focused on Proton-Exchange Membrane and Solid-Oxide Fuel Cells. In the low-temperature operation ranges, PEMFCs promise to be the leading alternative to internal combustion engines for vehicular applications. [9]

## 2.4 Fuel Cell operating principle

Fuel cells are based on the concept of an oxygen-ion conducting electrolyte, through which the oxide ions migrate from the cathode side to the anode side. the fuel flows along the fuel channel and through the anode until it reaches the anode-electrolyte interface, where it is oxidized releasing electrons to the electronic- conducting anode, that drives them to the interconnects and so to the external electric-circuit.[9] The fuel ions,  $H^+$ , react with the oxygen anions provided by the electrolyte,  $O^{2-}$ , giving the products of the electrochemical reaction,  $H_2O$ ; these flow away from this region through the porous anode to the channel, where they are convected to the outlet. On the other side of the electrolyte, a similar process takes place: oxygen (often air) is fed to the oxidant channel and flows through the cathode to the reaction sites on the cathode-electrolyte surface. Oxygen is there reduced taking two electrons from the cathode; the resulting oxygen ion,  $O^{2-}$ , enters the electrolyte matrix, and it is driven to the anode-electrolyte surface. <sup>1</sup>

---

1: See Appendix A

## 2.5 Fuel Cell designs

The basic components of a fuel cell can be assembled according to several configurations depending on:

1. The geometry as shown in figure

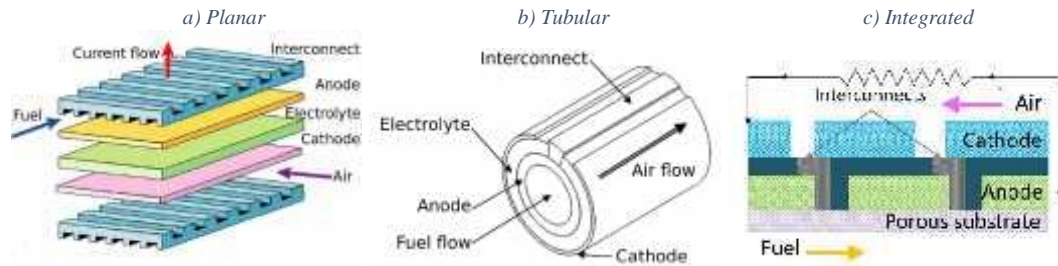

Figure 2.4 shows the three classifications of Fuel Cells [14]

- a) Planar Fuel Cells consist of flat layers placed one on top of each other. They are further classified as radial-planar, where the reactant gases diffuse through the porous electrode microstructure from the center to the periphery of the disk, and flat-plane planar, where reactant gases flow along the channels limited by the interconnects and the electrodes. The planar design allows to build Fuel Cell stacks just by piling Fuel Cells on top of each other; thus planar stacks are simple and have high power densities ( $\text{W cm}^{-3}$ ). The major disadvantages of the planar design are:
  - (i) The need for gas-tight sealing around the edge of the cell components.
  - (ii) The brittleness of planar Fuel Cells under mechanical and thermal stress.
  - (iii) Poor scalability of thin planar-layers.
- b) Tubular cells consist of three concentric and adjacent cylinders, made of the anode, electrolyte and cathode materials respectively. A stack of tubular Fuel Cell consists of a bundle of Fuel Cell tubes. The tubular design solves the brittleness and sealing problems that arise in the planar design. However, this geometry has high fabrication costs and lower power densities as a result of the long path for electrical power through each cell and the large voids within the stack structure. The power density depends upon the inverse of the cell diameter for tubular cells, which led K. Kendall, in the early 1990s, to

invent the micro- tubular Fuel Cell on the scale of millimeters in diameter. Micro tubular Fuel Cells have the advantage that they have short start-up times, are resistant to thermal degradation on cycling, and have high power densities and less stringent sealing requirements than planar cells. However, problems arise in the current collection and interconnects when using these micro tubular cells.

- c) The Integrated Planar Fuel Cell (IP-FC) is an innovative fuel cell concept developed by Rolls-Royce. It is a cross between tubular and planar geometries seeking to borrow the thermal compliance properties from the former and low cost component fabrication and short current paths from the latter.

## 2. Mechanical-support layer

According to the supporting layer, Fuel Cell single cells are further classified into two broad categories: self-supporting and externally supported. In the self-supporting configuration, one of the cell components (the thickest layer) acts as the cell structural support. Thus, single cells can be designed as electrolyte supported, anode supported, or cathode supported. In the externally supported configuration, a single cell is configured as thin layers on the interconnect or a porous substrate. The various cell configurations for Fuel Cells are schematically shown in figure 2.5.

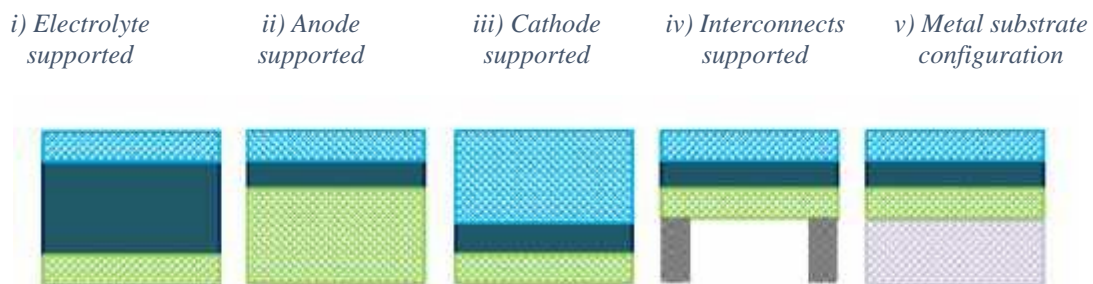

Figure 2.5 show the mechanical-support layer classifications [14]

Fuel Cell components thickness depending on the mechanical-support layer:

- (i) The mechanical strength of electrolyte-supported cells: stems from a thick dense electrolyte. Since the ohmic losses increase with the thickness of the electrolyte, this configuration suffers from a high ohmic overpotential, which is minimized operating the cell at high temperatures.
- (ii) Anode-supported cells: are mechanically supported in a thick porous anode, on the top of which a thin electrolyte is placed. Since the electrical conductivity of the anode is high and the electrolyte is thin the cell can operate at lower temperatures than those required by the electrolyte-supported configuration. However, a thicker anode is more vulnerable to reoxidation and may limit the mass transport through it.
- (iii) The cathode-supported configuration: is similar to the anode-supported in that the operating temperature can be lowered using a thin electrolyte; and in that the thicker cathode may hinder the supply of the reactants to the reaction-sites. However, the electrical conductivity of the cathode is worse than that of the anode, resulting in higher ohmic losses than those produced in the anode-supported configuration.
- (iv) Interconnect supported cells: allow the use of thin Fuel Cell component layers, reducing the ohmic and concentration overpotentials with respect to the self-supporting configurations. However, the interconnects may be oxidized, losing their mechanical strength, and the flow-field design is limited due to the cell support requirement.
- (v) A porous metal-substrate configuration: introduces a new material in the cell, which may lead to added problems in its fabrication or to the contamination of the cell components due to migration of impurities from the substrate to the electrodes. However, it allows to use thin layers of the cell components and to operate at low temperatures, without losing mechanical reliability or deteriorating the performance.

## 2.6 Safety precautions

The general safety strategy for dealing with the fuel cell systems shall be established according to the following sequence:

- Avoid the possible release of combustible and/or toxic gases and pollutant gases, liquids and solids.
- Eliminate hazards outside the fuel cell system and the related installation, when such energy or gases are released nearly instantaneously.
- Provide appropriate safety markings, concerning the remaining risks of hazards.

### Hazards

Using the techniques described above, special care shall be taken to address the following:

- Mechanical hazards; sharp surfaces, tripping hazards, moving masses and instability, strength of materials, and liquids or gases under pressure.
- Electrical hazards; contact of persons with live parts, short circuits, high voltage
- Thermal hazards; hot surfaces, release of high temperature liquids or gases, thermal fatigue.
- Fire and explosion hazards; flammable gases or liquids, potential for explosive mixtures during normal or abnormal operating conditions, potential for explosive mixtures during failure conditions.
- Malfunction hazards; unsafe operation of installation-related equipment due to failures of software, control circuit or protective/safety components.
- Hazards generated by erroneous human intervention; deviation from correct operation, errors of manufacturing, installation or maintenance, vandalism.
- Material and substance hazards; material deterioration, corrosion, embrittlement, toxic releases, choking hazards (e.g. by superseding, replacing oxygen with inert purge gases).
- Waste disposal hazards; disposal of toxic materials, recycling, disposal of flammable liquids or gases.
- Environmental hazards; unsafe operation in extreme hot/cold environments, rain, flooding, wind, earthquake, external fire, smoke or attack by vermin.
- Pollution to air, water, soil.

## **2.7 Previous Studies**

### **Electrification of Remote Clinics by Photovoltaic – Hydrogen Fuel Cell System.**

This contribution has been made in 2013, it provided a power management strategy for solar and fuel cell system scaled to suite a typical small clinic from rural areas in Palestine. In addition, experimental results for system part have been done on scaled system in the lab. The main purpose of that thesis was to investigate electrification of health clinics far from the electric grid, by environment friendly system consisting of photovoltaic generators and fuel cells. During the process of the fuel cell experiments showed that it should be supplied with hydrogen for three minutes before taking readings because membrane initially needs to stimulate the production of electricity an in order for the cell to operate efficiently. Distilled water should be used in the electrolyzer where the membrane is put in the process of separating water into hydrogen and oxygen. Non distilled water leads to the destruction of the membrane of the electrolyzer.

## **Chapter 3**

### **Comsol Multiphysics**

---

#### **3.1 Introduction**

#### **3.2 Comsol Multiphysics**

#### **3.3 The Batteries & Fuel Cells Module**

#### **3.4 Comsol Multiphysics steps:**

- ❖ **Step 1. Model.**
- ❖ **Step 2. Definitions.**
- ❖ **Step 3. Geometry.**
- ❖ **Step 4. Materials.**
- ❖ **Step 5. Physics.**
- ❖ **Step 6. Mesh.**
- ❖ **Step 7. Study.**
- ❖ **Step 8. Results.**

### 3.1 Introduction

Computer simulation has become an essential part of science and engineering. Digital analysis of components, in particular, is important when developing new products or optimizing designs. Today a broad spectrum of options for simulation is available; researchers use everything from basic programming languages to various high-level packages implementing advanced methods.

A computer simulation environment is simply a translation of real-world physical systems into their mathematical models. The accuracy of the numerical results depends on the simplification of the real physical system during mathematical modelling. In the present project Comsol Multiphysics has been used in the simulation of the Fuel Cell for its wide range of applications.

### 3.2 COMSOL Multiphysics

It is a Finite Element Analysis (FEA), solver and Simulation software (FEA) Software package for various physics and engineering applications, especially coupled phenomena or multiphysics.

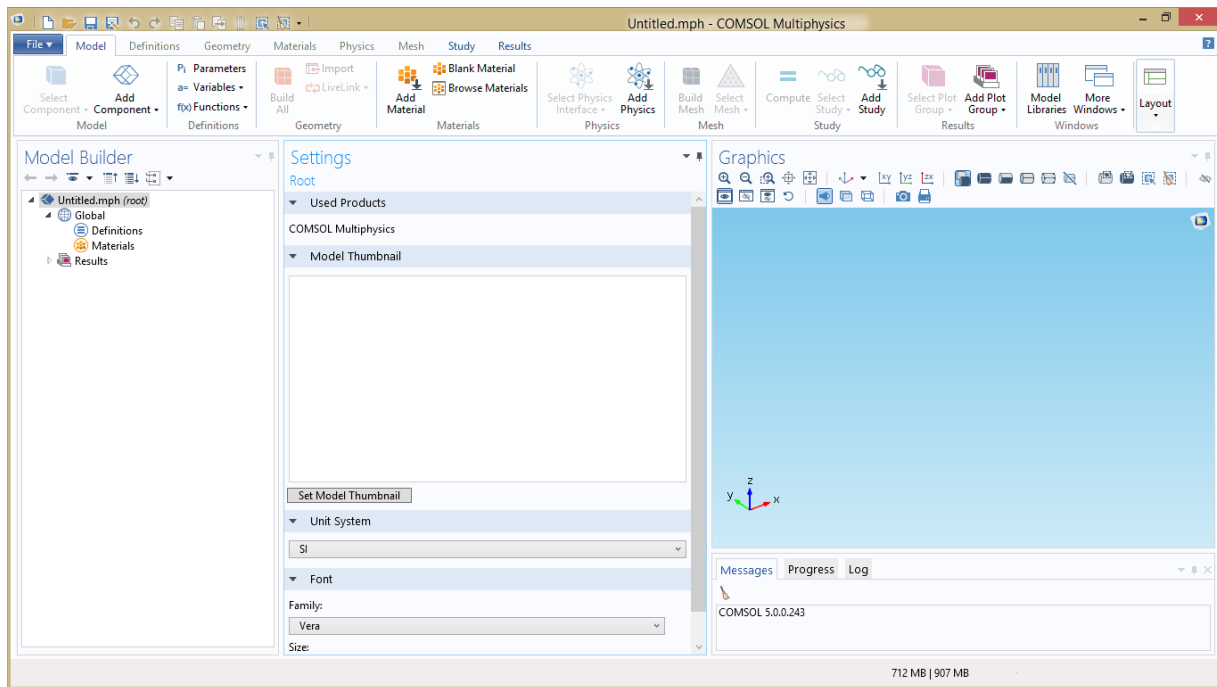

Figure 3.1 Comsol Multiphysics interface



It is capable of dealing with several kinds of simulations including:

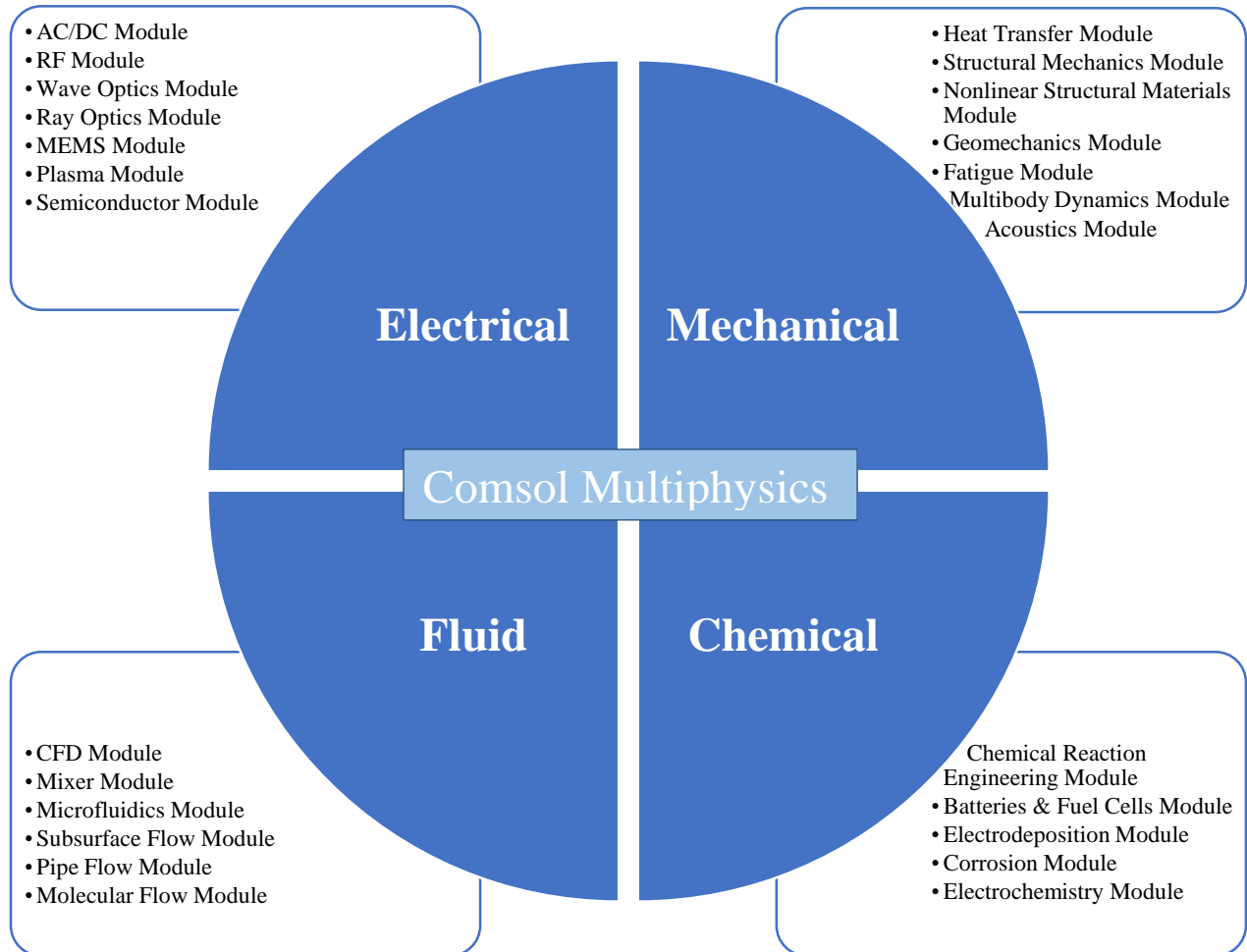

Figure 3.2 Comsol Multiphysics simulation types

For this project, we are going to use the chemical module for batteries and fuel cells and simulate Proton Exchange Membrane Fuel Cell and Solid Oxide Fuel Cell and make comparison between them.

### **3.3 The Batteries & Fuel Cells Module**

These models undergo electrochemical behavior in the electrodes and electrolytes of batteries and fuel cells. Using this software allows to simulate characteristics such as the transport of charged and neutral species, current conduction, fluid flow, heat transfer, and the nature and driving forces of electrochemical reactions at planar and in porous electrodes.

Using this understanding of these characteristics, the designer could design and optimize the geometries and material of system's electrodes, separators, membranes, electrolyte, and current collectors and feeders with respect to performance, thermal management, and safety.

In this study, the physical interfaces that were used are: Chemical Species Transport, Electrochemistry and Fluid Flow.

### **3.4 Comsol Multiphysics Steps**

Comsol multiphysics has 8 different steps to follow in order to create a study, these procedures are:

Step 1. Model.

Step 2. Definitions.

Step 3. Geometry.

Step 4. Materials.

Step 5. Physics.

Step 6. Mesh.

Step 7. Study.

Step 8. Results.

## Step 1. Model

To start any study using Comsol Multiphysics, it is needed to identify the model that is shown in the figure 3.3.

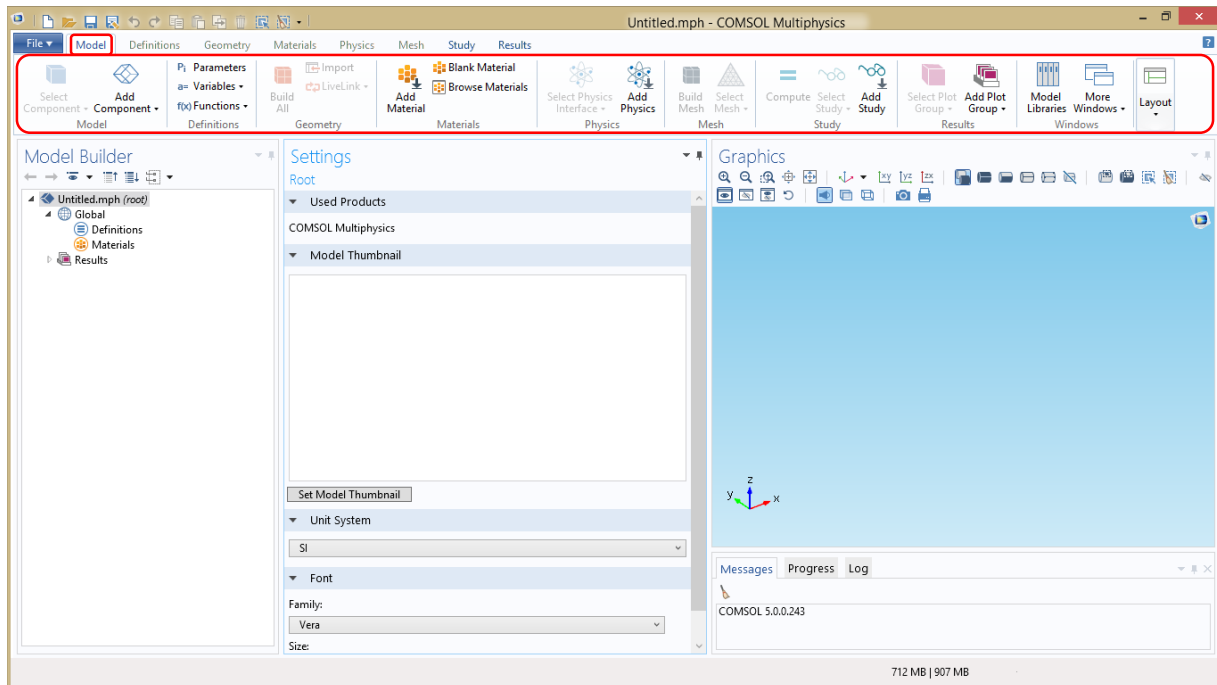

Figure 3.3 Comsol Multiphysics Model Window

Figure 3.3 shows model window and its components, it has shortcut to the other windows Definitions, Geometry, Materials, Physics, Mesh, Study, and Results.

From this window you can adding parameters, importing from other softwares, adding materials, adding physics, and adding study.

## Step 2. Definitions

This branch contains user defined variables, selections, views, pairs, functions, probes, component couplings, and coordinate systems, which are defined for the model.

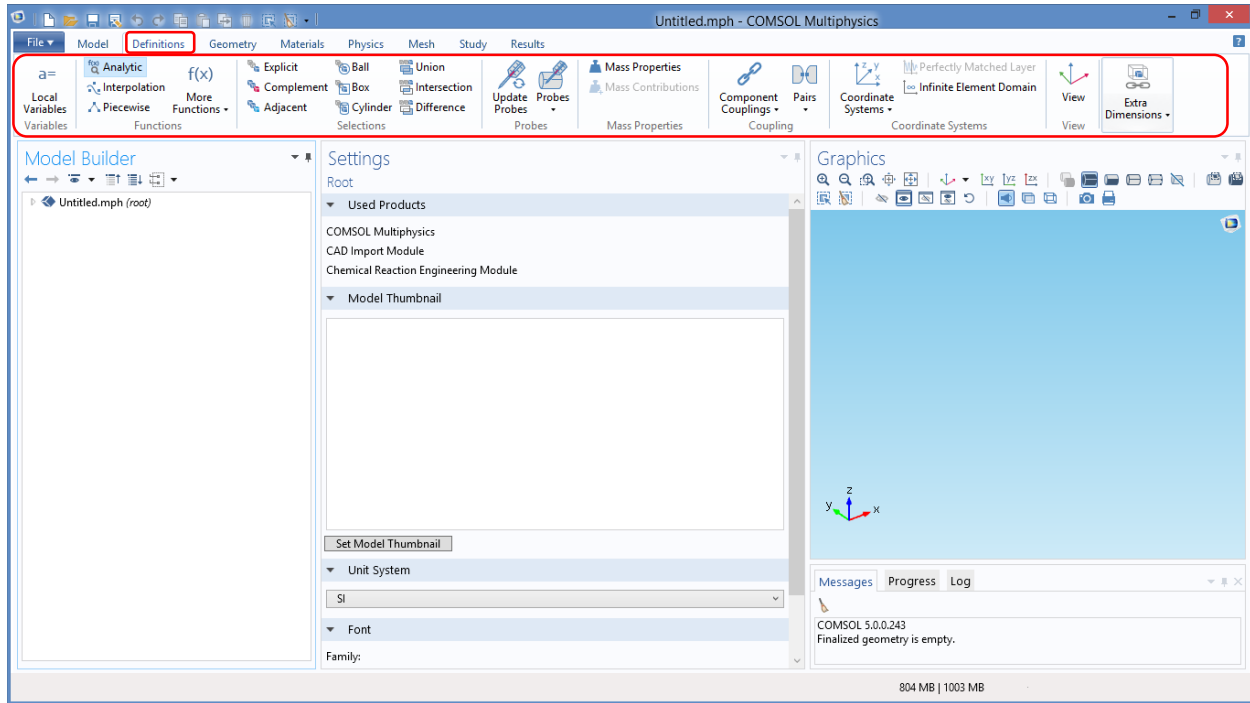

Figure 3.4 Comsol Multiphysics Definition Window

Figure 3.4 shows definition window and its components.

From this window you can adding explicit, ball, union, cylinder, box, difference, probes, and mass properties.

### Step 3. Geometry

The geometry branch allows to build the model with the desired dimensions and shapes, it also allows to import readymade models created CAD softwares.

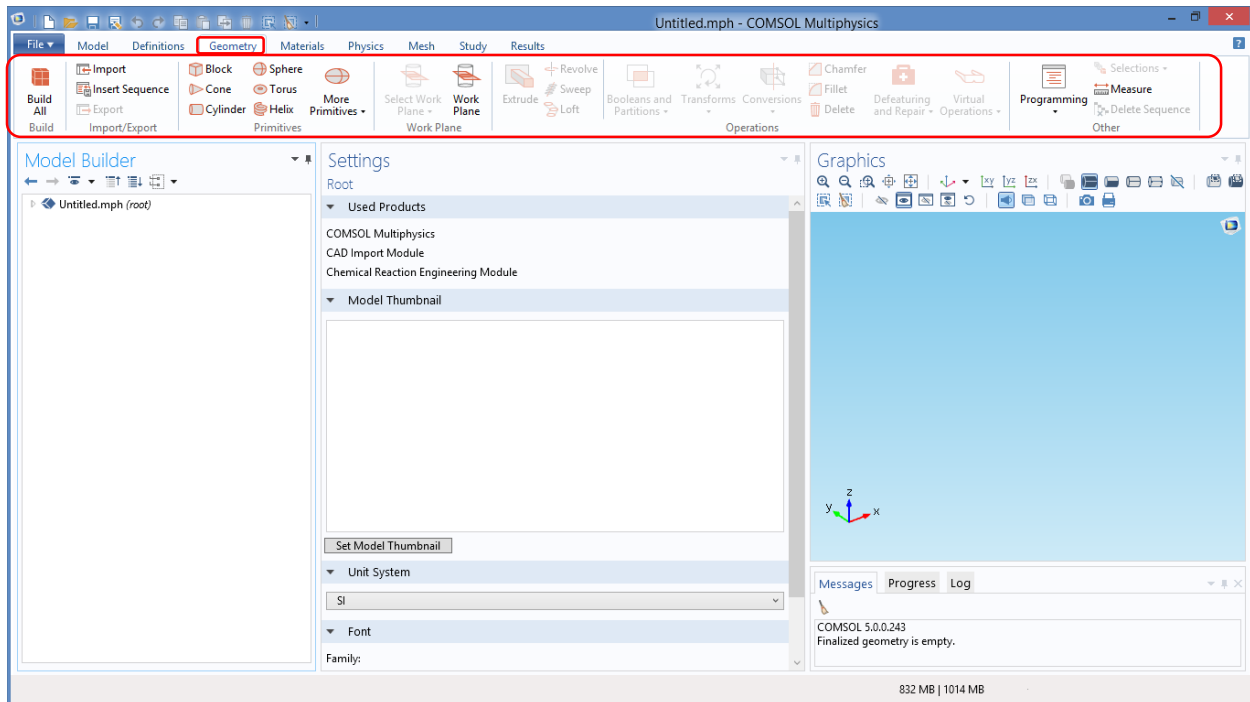

Figure 3.5 Comsol Multiphysics Geometry Window

Figure 3.5 shows geometry window and its components.

From this window you can adding block, sphere, union, cone, torus, cylinder, extrude, and work plane.

## Step 4. Materials

This branch gives the ability to add the material type to the model, the material is given the same properties as in real world, a model can be given more than one type of material, this branch contains pre-made libraries in COMSOL.

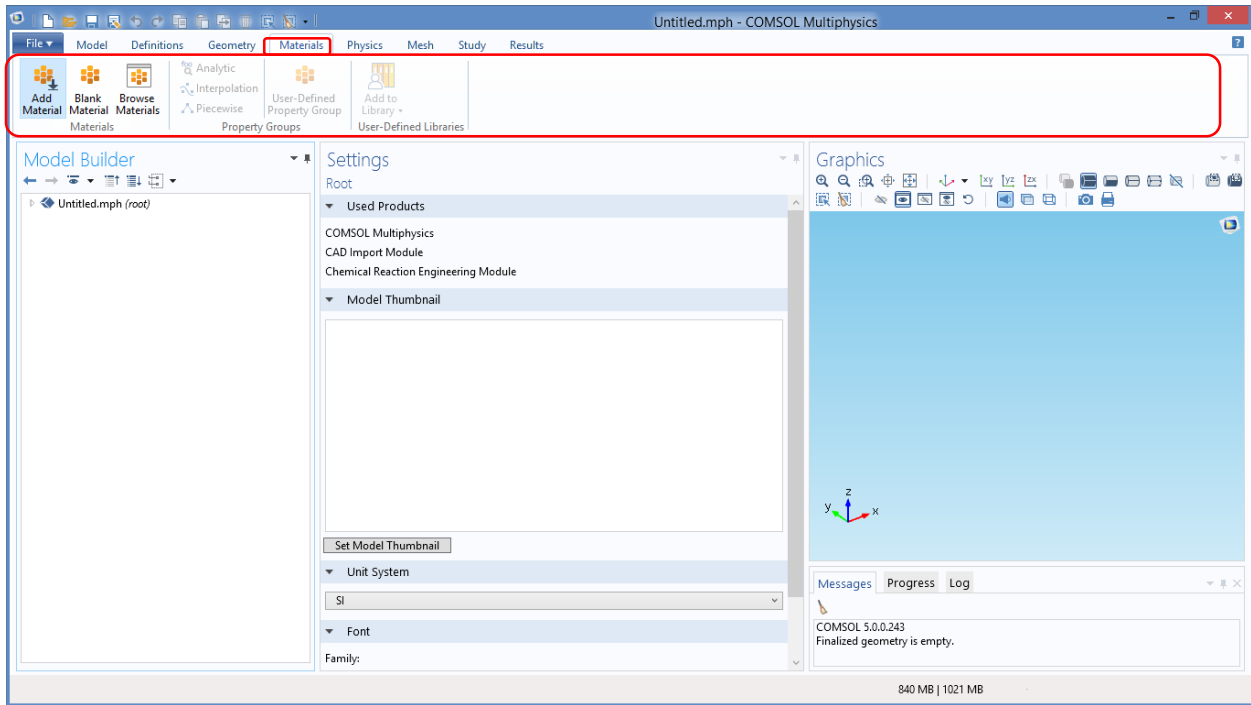

Figure 3.6 Comsol Multiphysics Materials Window

Figure 3.6 shows materials window and its components.

From this window you can adding material, browse materials, and change properties of material use.

Figure 3.7 shows some of materials in comsol Multiphysics material library.



Figure 3.7 Comsol Multiphysics Materials Library

## Step 5. Physics

This branch is used to identify domains, boundaries, pairs, edges and attributes of the model.

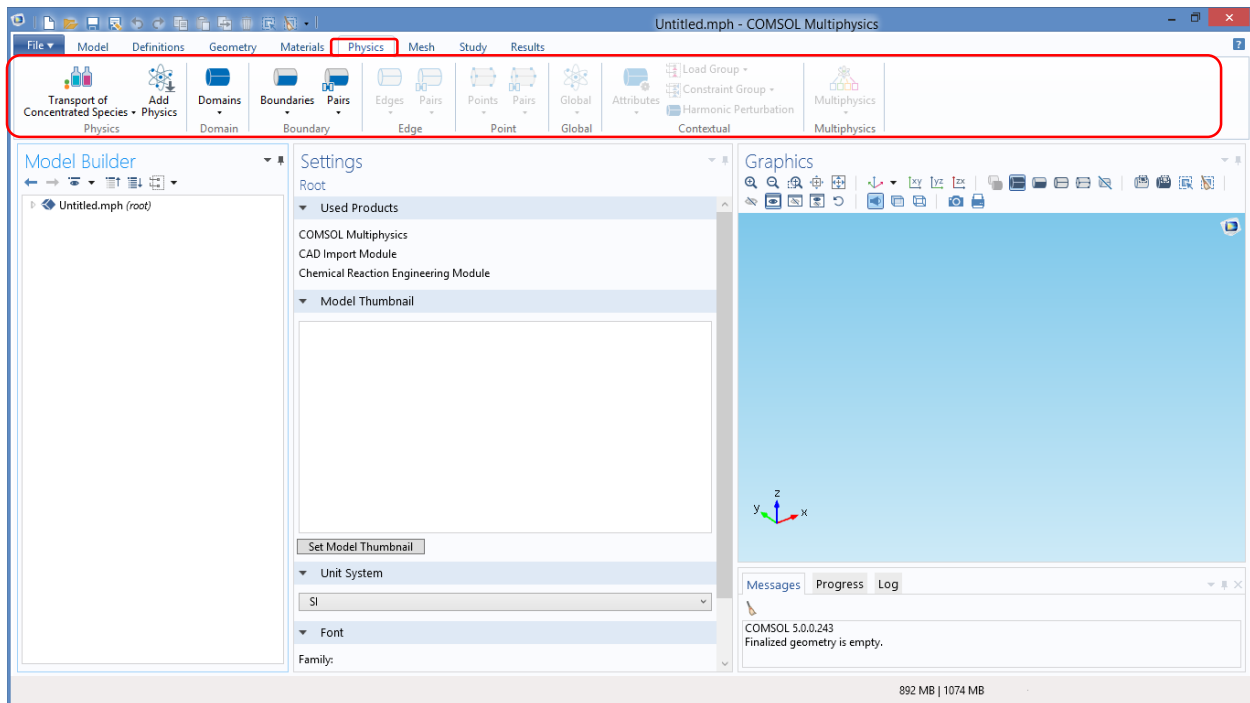

Figure 3.8 Comsol Multiphysics Physics Window

Figure 3.8 shows physics window and its components.

From this window you can adding physics, pairs, and load group of physics.

## Step 6. Mesh

The Mesh branch enables the discretization of the geometry into small units of simple shapes, referred to as mesh elements.

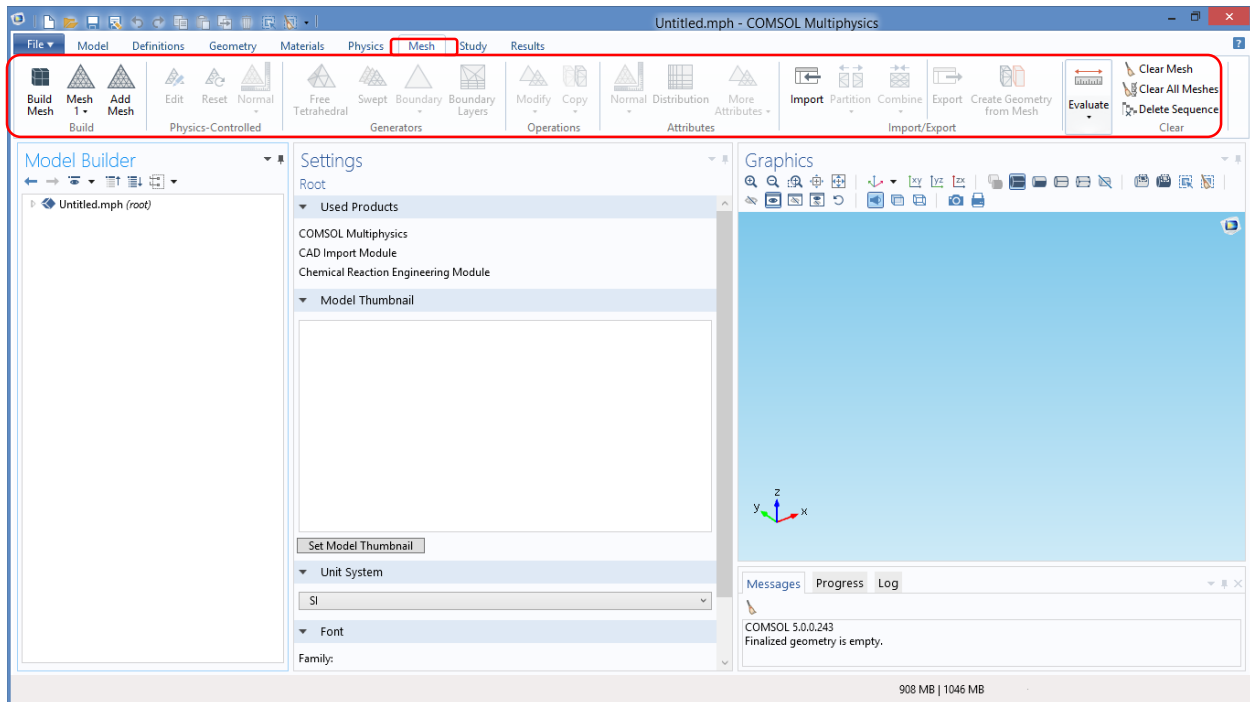

Figure 3.9 Comsol Multiphysics Mesh Window

Figure 3.9 shows mesh window and its components.

From this window you can adding & edit mesh, adding swept, and chose the size of meshing in your simulation.



## Step 7. Study

The Study branch allows for the editing on the study properties identified in previous steps before computing.

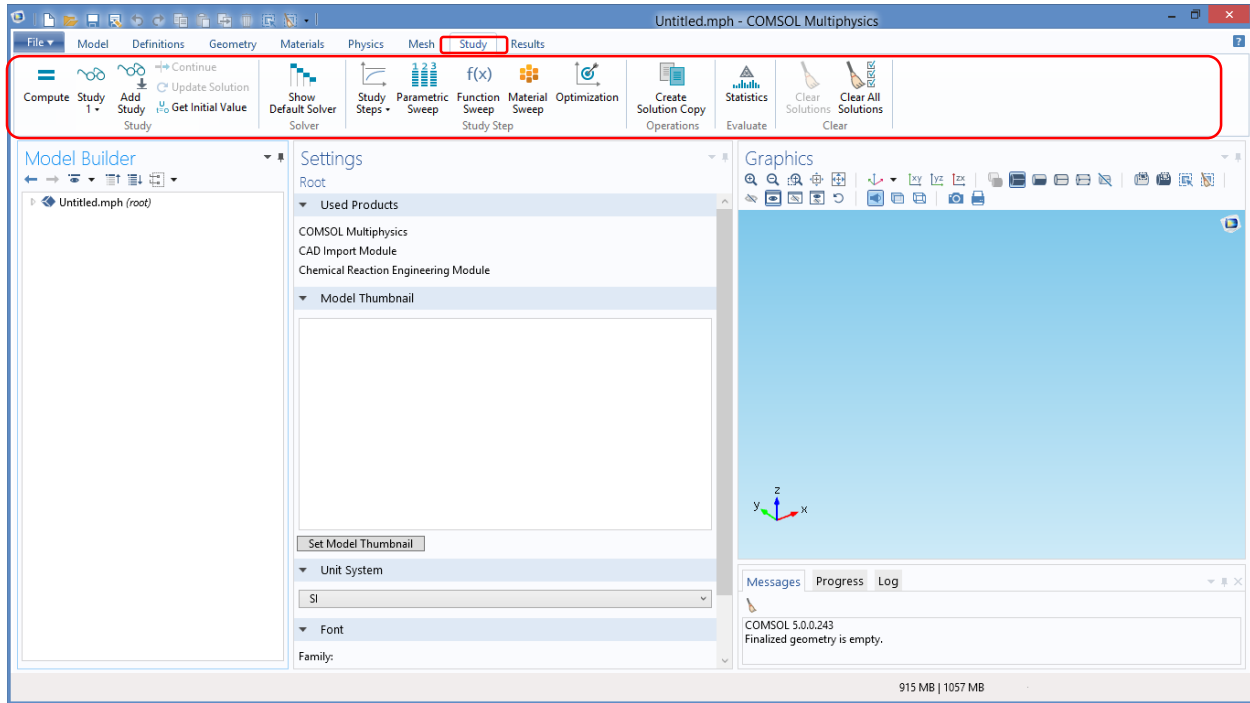

Figure 3.10 Comsol Multiphysics Study Window

Figure 3.10 shows study window and its components.

From this window you can adding study, showing steps, statistics, clear all solutions, and computing of chosen study.

## Step 8. Results

This is the last step in the study procedure where the results are created and shape deformations and other visual results are rendered.

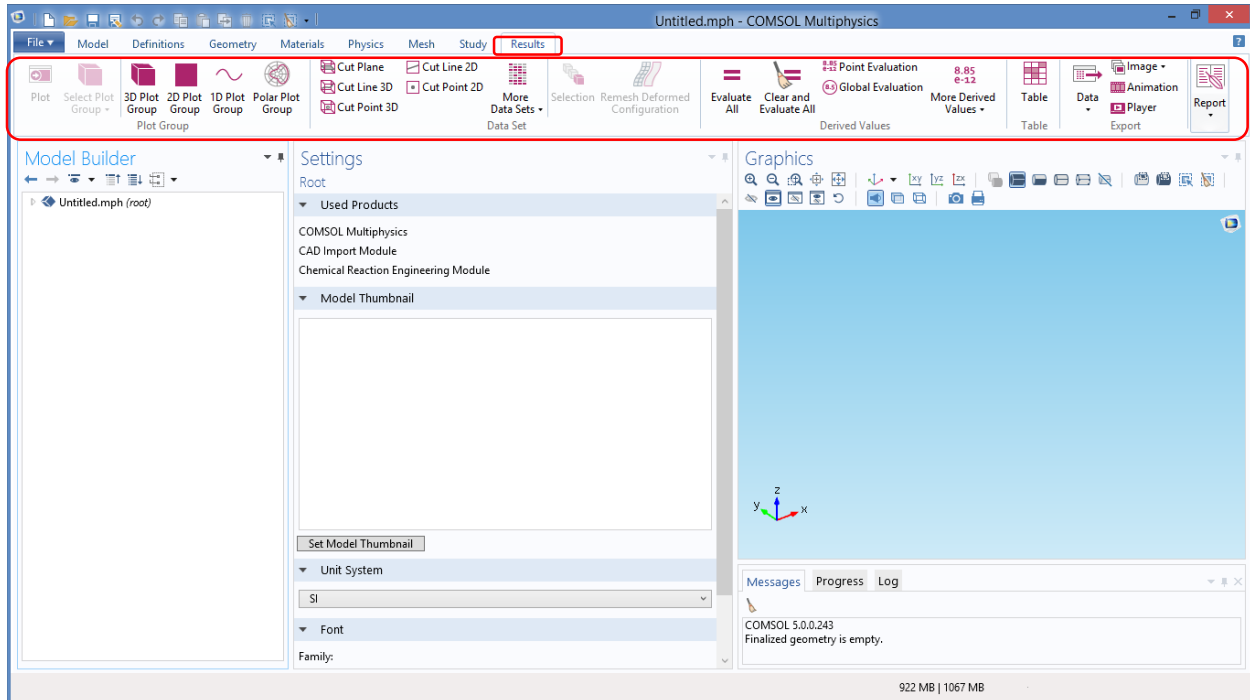

Figure 3.11 Comsol Multiphysics Results Window

Figure 3.11 shows results window and its components.

From this window you can adding 1D, 2D, 3D, and polar plot to show the results.

You can cut plane & line & point 1D, 2D, 3D, evaluate, and making animation.

This is Comsol Multiphysics steps in general, in chapter 4 & 5 details of simulation step by step.

## **Chapter 4**

### **Simulation of Solid Oxide Fuel Cell (SOFC) by using Comsol Multiphysics Program**

---

#### **4.1 Model**

#### **4.2 Definitions**

#### **4.3 Geometry**

#### **4.4 Physics**

#### **4.5 Mesh**

#### **4.6 Study**

#### **4.7 Results**

## 4.1 Model

### NEW

1- In the New window, click Model Wizard.

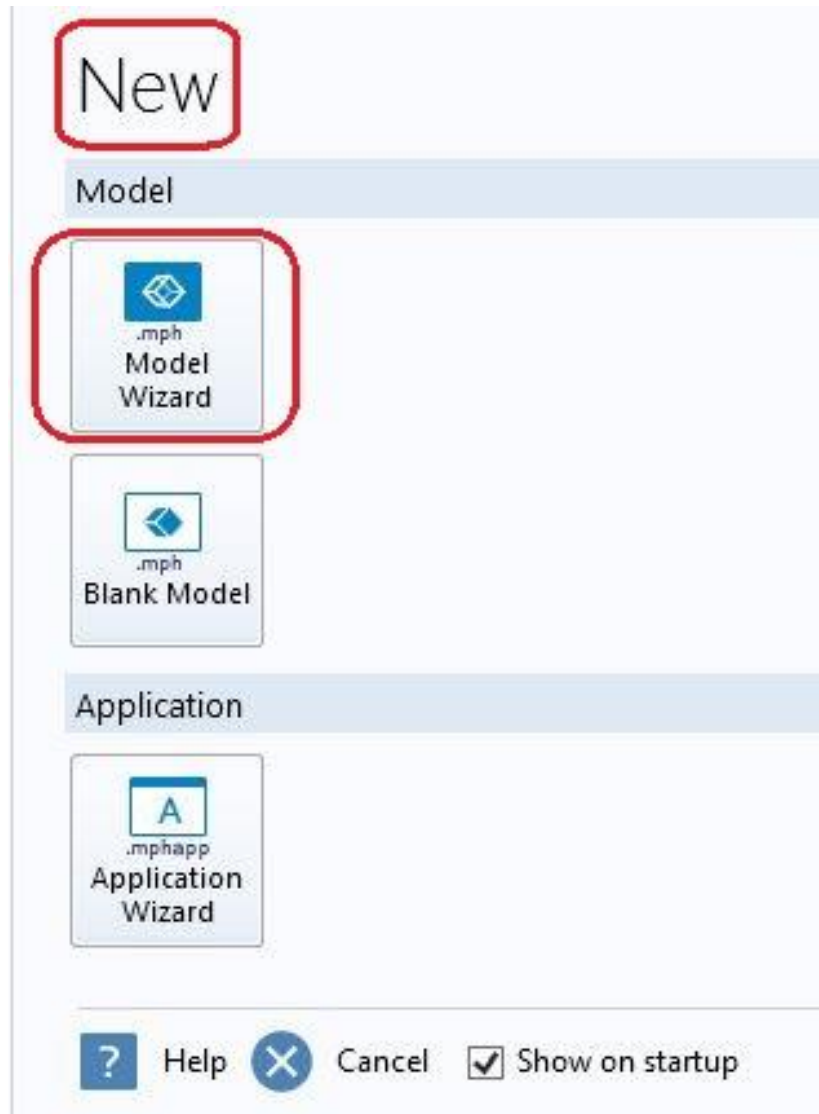

Figure 4.1 New Window

## MODEL WIZARD

1- In the Model Wizard window, click 3D.

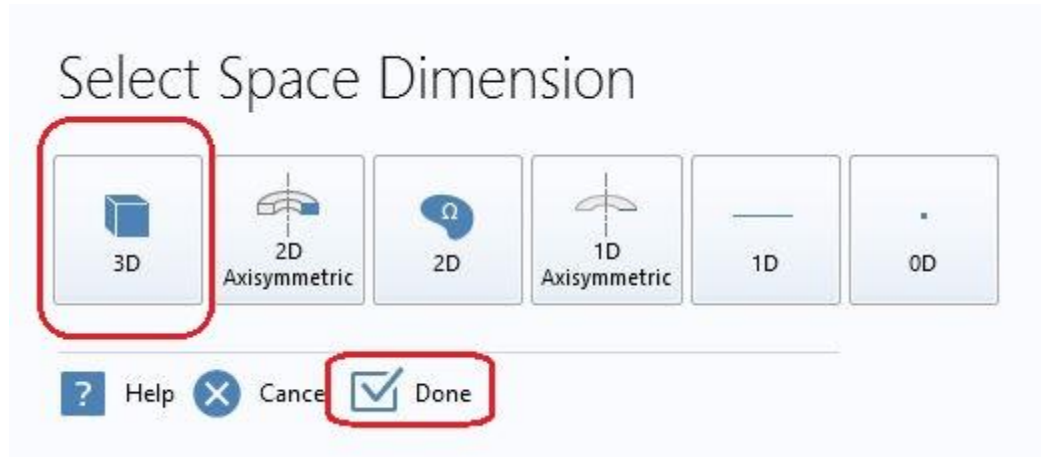

Figure 4.2 Select Space Dimension Window

2- In the Select physics tree, select Electrochemistry>Secondary Current Distribution (siec).

3-Click Add.

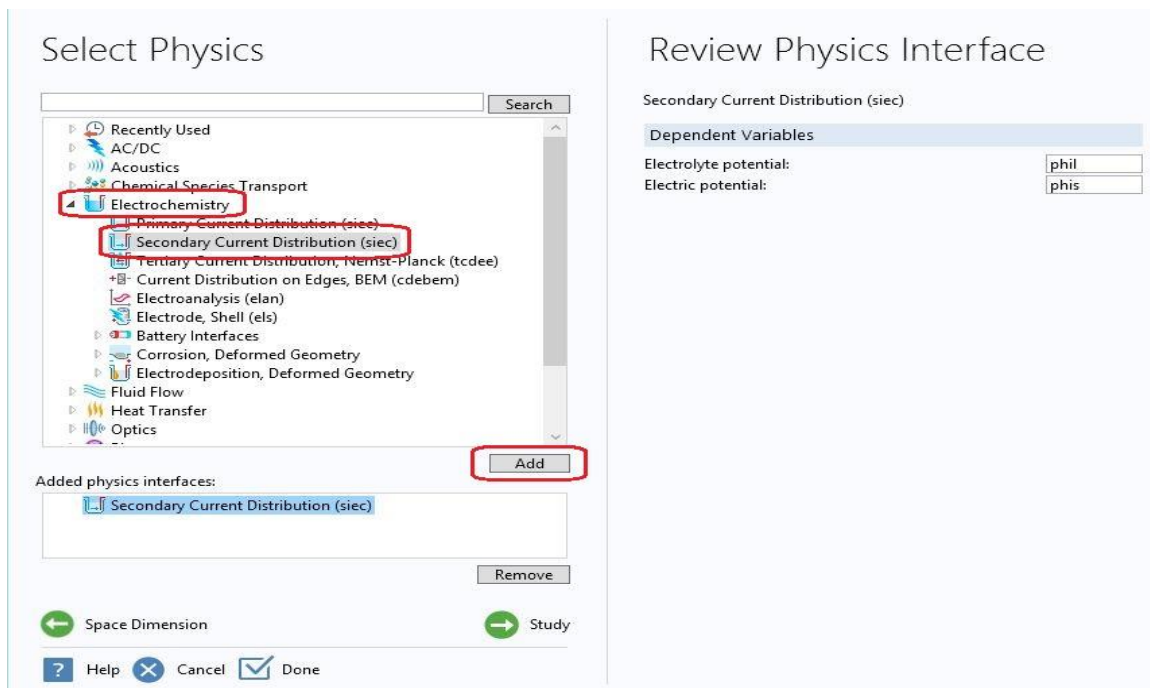

Figure 4.3 Select Physics Window (1)

4- In the Select physics tree, select Chemical Species Transport>Transport of Concentrated Species (tcs).

5- Click Add.

6- Click Add Mass Fraction.

7- In the Mass fractions table, enter the following settings:

wO2
wH2Oc
wN2

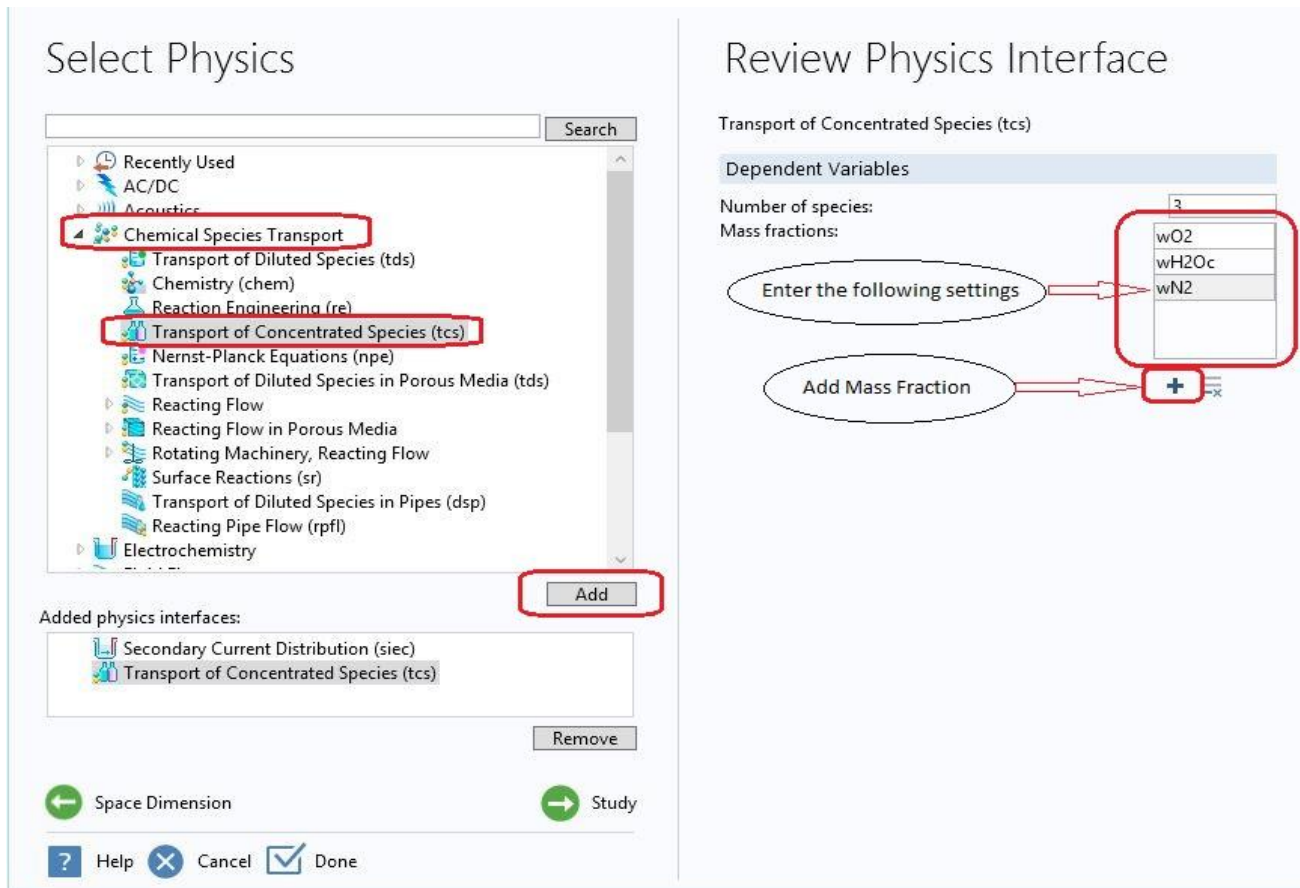

Figure 4.4 Select Physics Window (2)

8- In the Select physics tree, select Chemical Species Transport>Transport of Concentrated Species (tcs).

9- Click Add.

10- In the Mass fractions table, enter the following settings:

wH2
wH2Oa

- Note: these step as same as in step 4 to 7.

11- In the Select physics tree, select Fluid Flow>Porous Media and Subsurface Flow>Free and Porous Media Flow (fp).

12- Click Add.

13- In the Added physics interfaces tree, select Free and Porous Media Flow (fp).

14- In the Velocity field text field, type uc.

15- In the Velocity field components table, enter the following settings:

uc
vc
wc

16- In the Pressure text field, type pc.

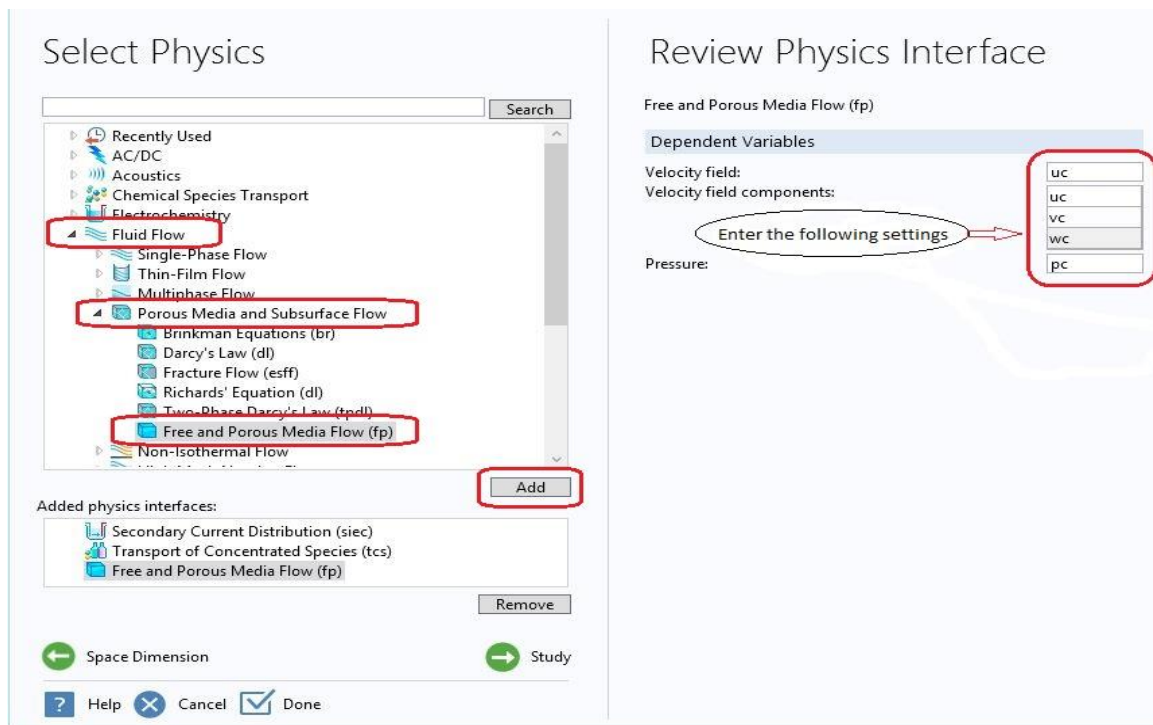

Figure 4.5 Select Physics Window (3)

17- In the Select physics tree, select Fluid Flow>Porous Media and Subsurface Flow>Free and Porous Media Flow (fp).

18- Click Add.

19- In the Added physics interfaces tree, select Free and Porous Media Flow (fp2).

20- In the Velocity field text field, type ua.

21- In the Velocity field components table, enter the following settings:

Ua
Va
Wa

22- In the Pressure text field, type pa.

23- Click Study.

- Note: these step as same as in step 11 to 16.

24- In the Select study tree, select Preset Studies for Selected Physics Interfaces>Stationary.

25- Click Done.







# Select Study

- ▲ Preset Studies for Selected Physics Interfaces
  - AC Impedance Stationary
  - AC Impedance Time Dependent
  - Stationary**
  - Time Dependent
- ▶ Custom Studies

Added study:

 Stationary

Added physics interfaces:

-  Secondary Current Distribution (siec)
-  Transport of Concentrated Species (tcs)
-  Transport of Concentrated Species (tcs2)
-  Free and Porous Media Flow (fp)
-  Free and Porous Media Flow (fp2)

 Physics

 Help  Cancel  Done

Figure 4.6 Select Study Window

## 4.2 Definitions

- 1- On the Model toolbar, click Parameters.
- 2- In the Settings window for Parameters, locate the Parameters section.
- 3- Click Load from File.

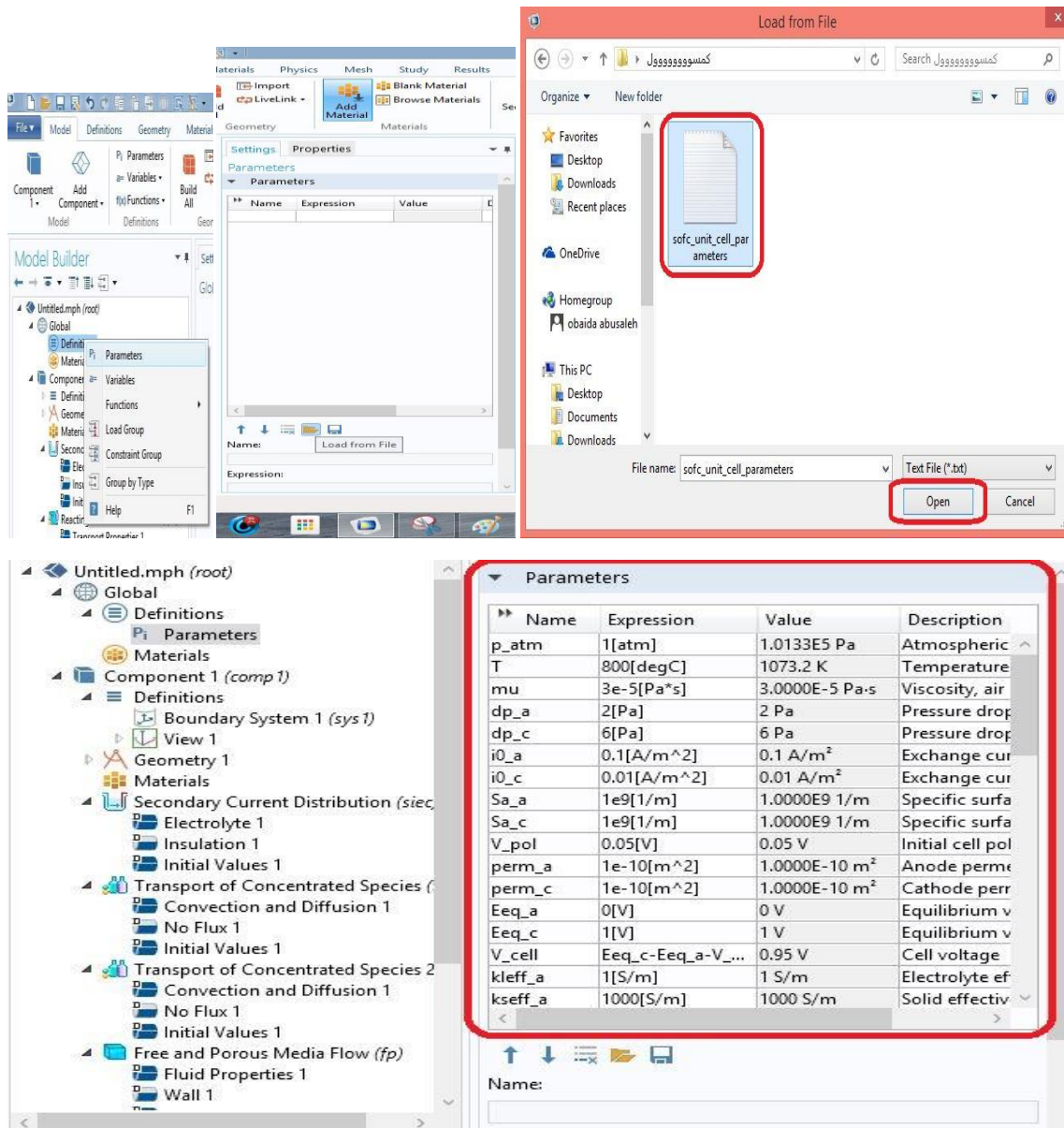

Figure 4.7 Loading Parameters Windows

## 4.3 GEOMETRY

Create the geometry by first defining the 2D cross section of the device, then extrude it to create the 3D model geometry.

Draw the channels, gas diffusion layers, porous electrodes and the membrane using rectangular blocks.

### Work Plane 1 (wp1)

- 1- On the Geometry toolbar, click Work Plane.
- 2- In the Settings window for Work Plane, locate the Plane Definition section.
- 3- From the Plane list, choose yz-plane.

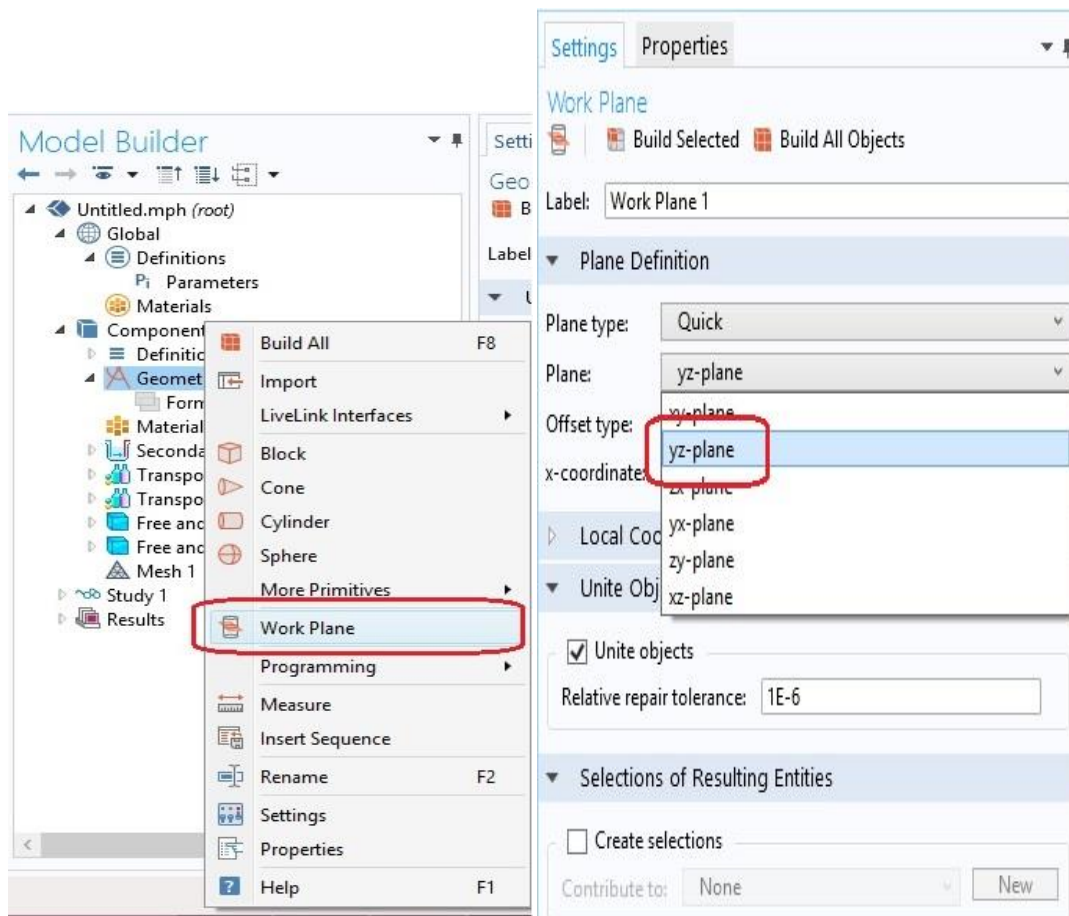

Figure 4.8 Loading Work Plane 1 Windows

## Add Rectangle as described below.

### Rectangle 1 (r1)

- 1- On the Work plane toolbar, click Primitives and choose Rectangle.
- 2- In the Settings window for Block, locate the Size section.
- 3- In the Width text field, type  $W_{\text{channel}}+W_{\text{rib}}$ .
- 4- In the Height text field, type  $H_{\text{gde}}$ .
- 5- Click the Build Selected button.
- 6- Click the Zoom Extents button on the Graphics toolbar.

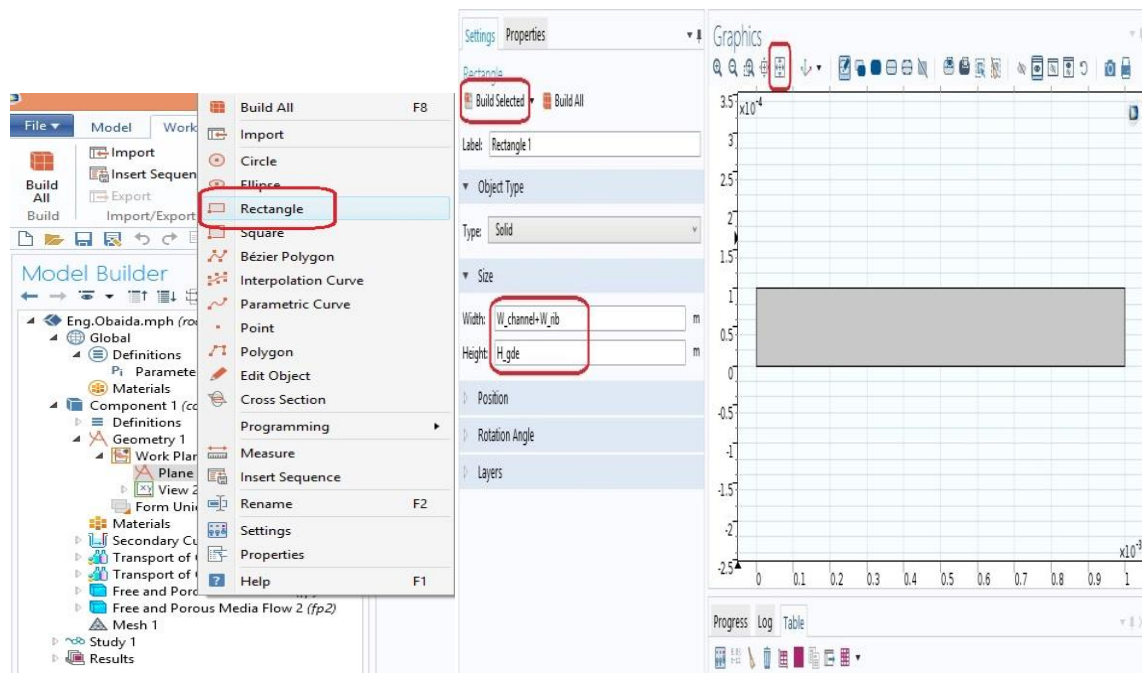

Figure 4.9 Loading Rectangle 1 Windows

### **Rectangle 2 (r2)**

- 1- On the Work plane toolbar, click Primitives and choose Rectangle.
- 2- In the Settings window for Rectangle, locate the Size section.
- 3- In the Width text field, type  $W_{\text{channel}}+W_{\text{rib}}$ .
- 4- In the Height text field, type  $H_{\text{electrolyte}}$ .
- 5- Locate the Position section. In the yw text field, type  $-H_{\text{electrolyte}}$ .
- 6- Click the Build Selected button

- Note. These step the same as step **Rectangle 1**

### **Rectangle 3 (r3)**

- 1- On the Work plane toolbar, click Primitives and choose Rectangle.
- 2- In the Settings window for Rectangle, locate the Size section.
- 3- In the Width text field, type  $W_{\text{channel}}+W_{\text{rib}}$ .
- 4- In the Height text field, type  $H_{\text{gde}}$ .
- 5- Locate the Position section. In the yw text field, type  $-H_{\text{electrolyte}}-H_{\text{gde}}$ .
- 6- Click the Build Selected button.

- Note. These step the same as step **Rectangle 1**

### **Rectangle 4 (r4)**

- 1- On the Work plane toolbar, click Primitives and choose Rectangle.
- 2- In the Settings window for Rectangle, locate the Size section.
- 3- In the Width text field, type  $W_{\text{channel}}$ .
- 4- In the Height text field, type  $H_{\text{channel}}$ .
- 5- Locate the Position section. In the xw text field, type  $W_{\text{rib}}/2$ .
- 6- In the yw text field, type  $H_{\text{gde}}$ .
- 7- Click the Build Selected

- Note. These step the same as step **Rectangle 1**

### **Rectangle 5 (r5)**

- 1- On the Work plane toolbar, click Primitives and choose Rectangle.
- 2- In the Settings window for Rectangle, locate the Size section.

- 3- In the Width text field, type  $W_{channel}$ .
  - 4- In the Height text field, type  $H_{channel}$ .
  - 5- Locate the Position section. In the  $xw$  text field, type  $W_{rib}/2$ .
  - 6- In the  $yw$  text field, type  $-H_{gde}-H_{electrolyte}-H_{channel}$ .
  - 7- Click the Build Selected button.
  - 8- Click the Zoom Extents button on the Graphics toolbar.
- Note. These step the same as step **Rectangle 1**

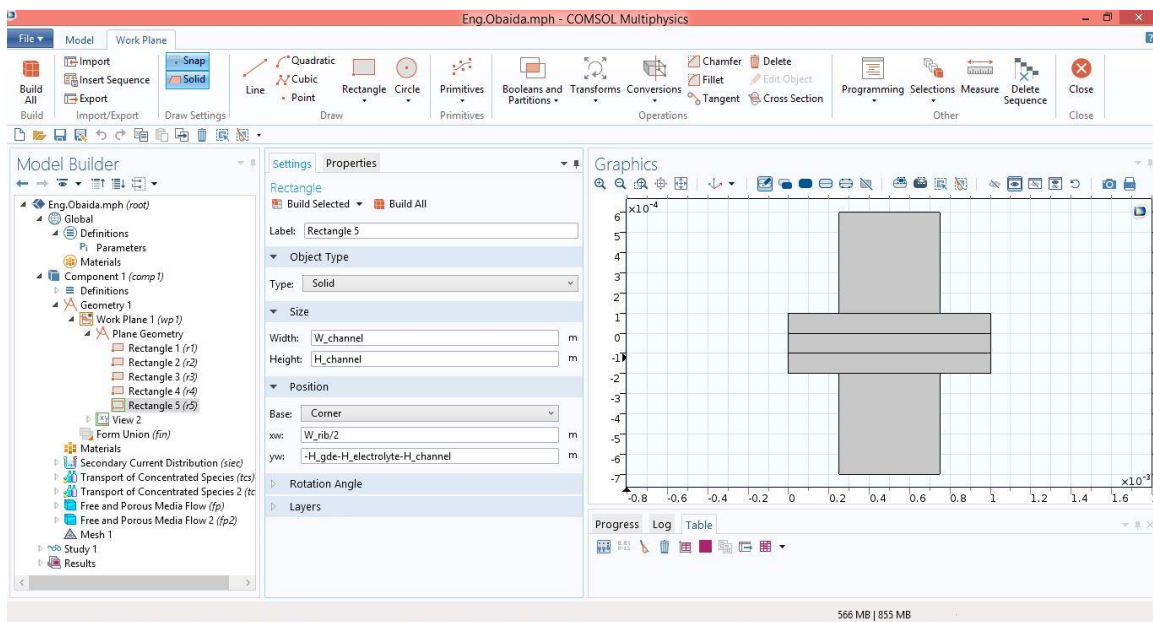

Figure 4.10 Fuel Cell Blocks

## Extrude planar faces into 3D objects.

### Extrude 1 (ext1)

From the **Extrude from** list, select **Faces** to extrude planar faces from the 3D geometry. Select the faces that you want to extrude in the Graphics window. They appear in the **Input faces** list. All selected faces must lie in the same plane.

- 1- On the Geometry toolbar, click Extrude.
- 2- In the Settings window for Extrude, locate the Distances from Plane section.
- 3- In the table, enter the following

Distances (m)
L

- 4- Click the Build All Objects button.
- 5- Click the Zoom Extents button on the Graphics toolbar.

The model geometry is now complete, and it should look like that in the figure below.

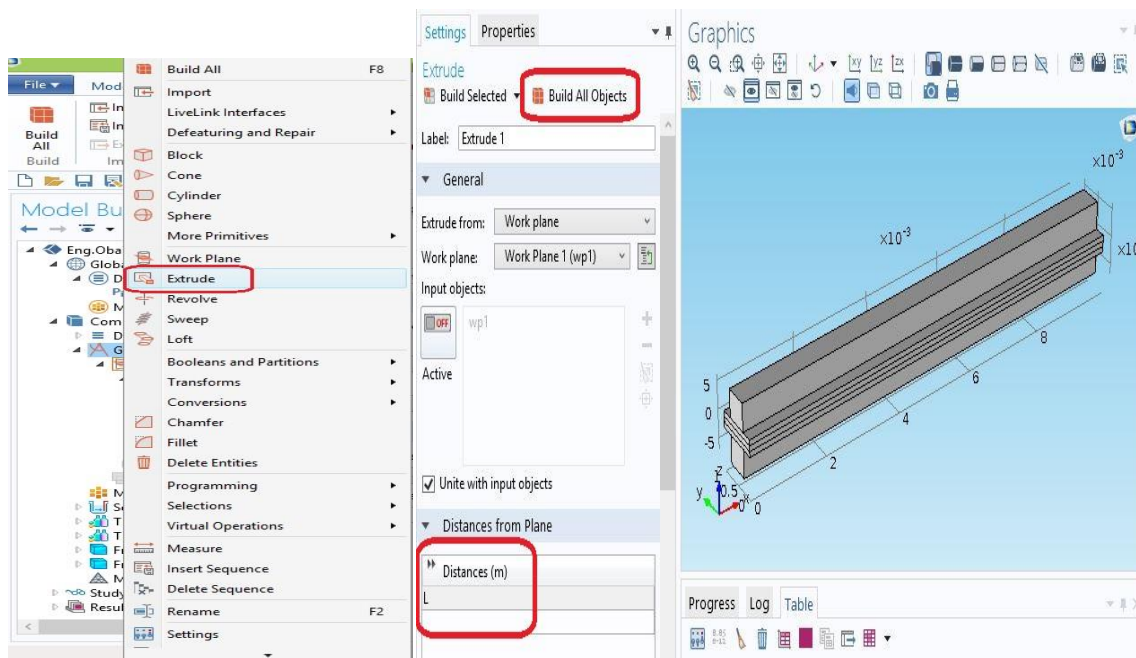

Figure 4.11 Fuel Cell shape

### 4.3.1 DEFINITIONS

Now make a number of selections to facilitate choosing different parts of the geometry when setting up the model.

Use an Explicit node to create the selection using the selection tools for individual geometric entities (boundaries, for example) on the chosen geometric entity level.

#### Explicit 1

1- On the Definitions toolbar, click Explicit.

2- Select Domain 4 only.

3- Right-click Component 1 (comp1)>Definitions>Explicit 1 and choose Rename.

4- In the Rename Explicit dialog box, type Anode Flow Channel in the New label text field.

5- Click OK.

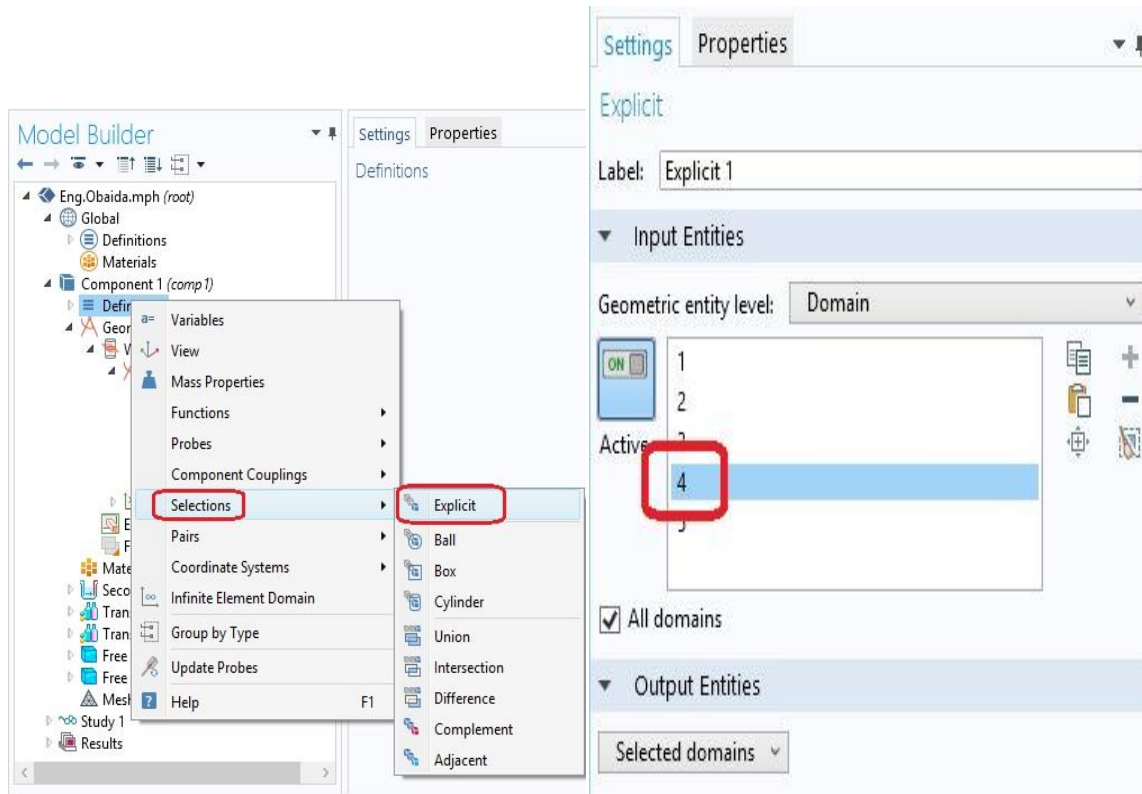

Figure 4.12 Making explicit in Definition Window



## **Explicit 2**

- 1- On the Definitions toolbar, click Explicit.
- 2- Select Domain 1 only.
- 3- Right-click Component 1 (comp1)>Definitions>Explicit 2 and choose Rename.
- 4- In the Rename Explicit dialog box, type Anode Electrode in the New label text field.
- 5- Click OK.

- Note. These step the same as step **Explicit 1**

## **Explicit 3**

- 1- On the Definitions toolbar, click Explicit.
- 2- Select Domain 3 only.
- 3- Right-click Component 1 (comp1)>Definitions>Explicit 3 and choose Rename.
- 4- In the Rename Explicit dialog box, type Cathode Electrode in the New label text field.
- 5- Click OK.

- Note. These step the same as step **Explicit 1**

## **Explicit 4**

- 1- On the Definitions toolbar, click Explicit.
- 2- Select Domain 5 only.
- 3- Right-click Component 1 (comp1)>Definitions>Explicit 4 and choose Rename.
- 4- In the Rename Explicit dialog box, type Cathode Flow Channel in the New label text field.
- 5- Click OK.

- Note. These step the same as step **Explicit 1**

## Boundary Probe

A boundary probe monitors the development of a scalar-valued quantity (real or complex-valued number) from a time-dependent, frequency-domain, or parametric simulation by two different

Add a boundary probe for the average cell current density, it will be plotted during the solver process.

6- On the Definitions toolbar, click Probes and choose Boundary Probe.

7- In the Settings window for Boundary Probe, locate the Source Selection section.

8- Click Clear Selection.

9- Select Boundary 6 only.

10- Locate the Expression section. Click  $s_{iec}.llz$  - Electrolyte current density vector, z component in the upper-right corner of the section.

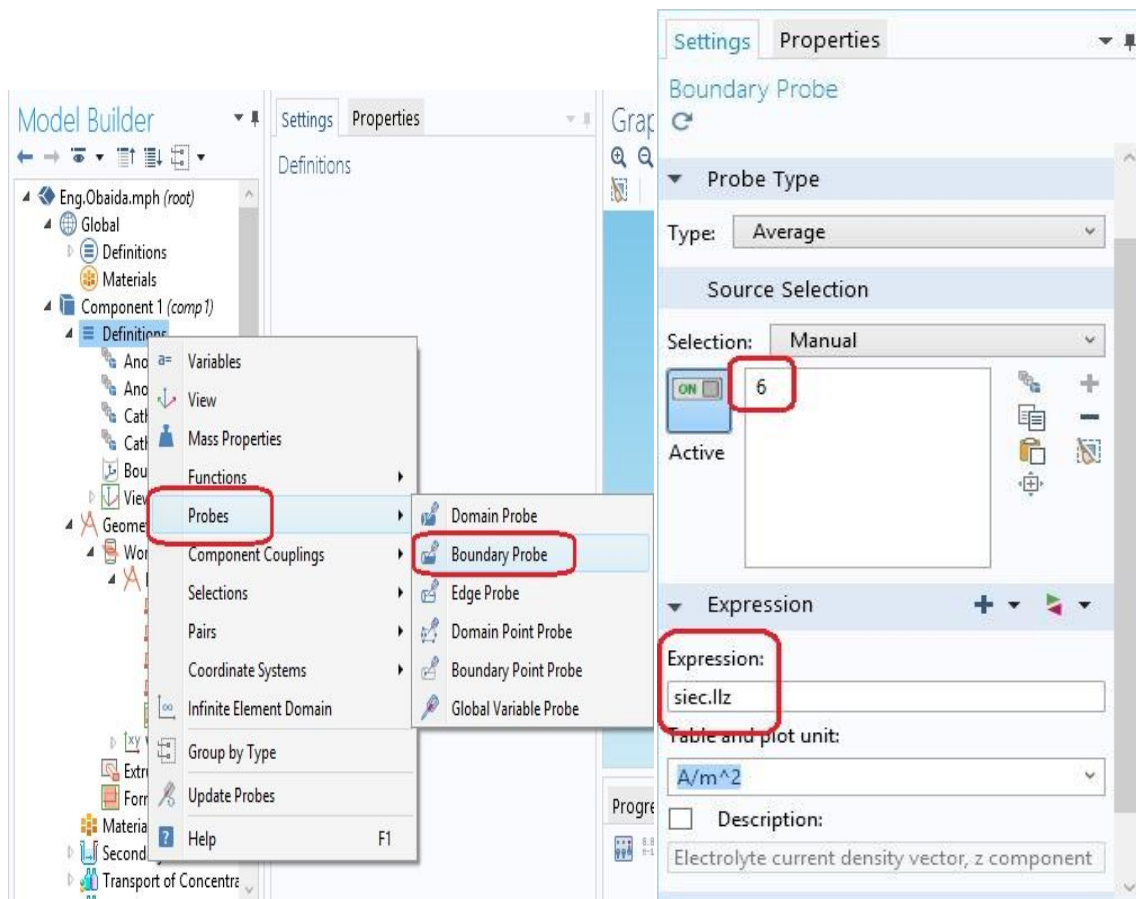

Figure 4.13 Making boundary probe in Definition Window

## 4.4 Physics

### 4.4.1 SECONDARY CURRENT DISTRIBUTION (SIEC)

The Primary Current Distribution interface defines the transport of charged ions in an electrolyte of uniform composition as well as current conduction in electrodes using Ohm's law in combination with a charge balance.

Now start setting up the current distribution model. It consists of:

- Porous electrodes
- One electrolyte domain.

1- In the Model Builder window, under Component 1 (comp1) click Secondary Current Distribution (siec).

2- Select Domains 1–3 only.

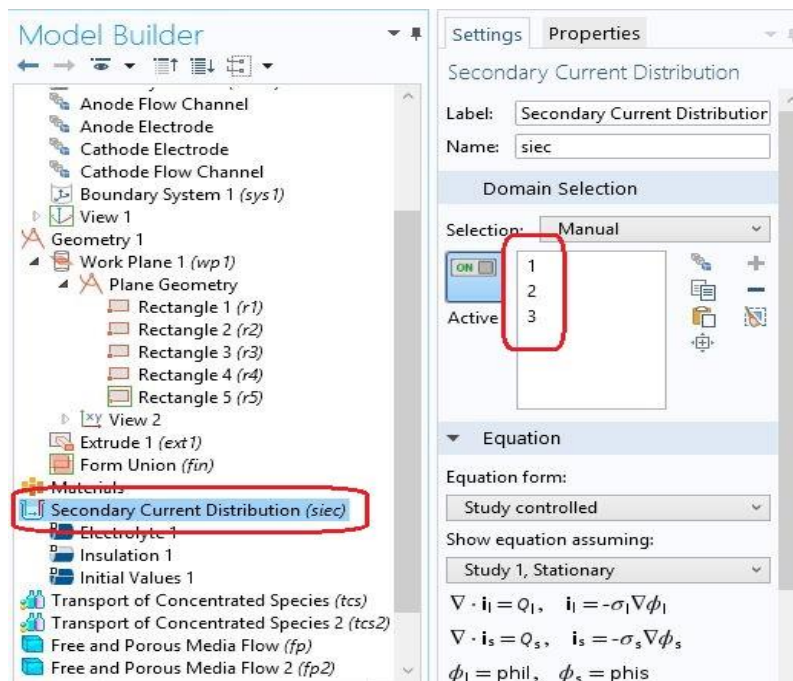

Figure 4.14 Making Secondary Current Distribution (siec) in Model Builder window.

- **Porous Electrode 1**

- 1- On the Physics toolbar, click Domains and choose Porous Electrode.
- 2- In the Settings window for Porous Electrode, locate the Domain Selection section.
- 3- From the Selection list, choose Anode Electrode.
- 4- Locate the Electrolyte Current Conduction section. From the  $\sigma_l$  list, choose User defined. In the associated text field, type `kleff_a`.
- 5- From the Effective conductivity correction list, choose No correction.
- 6- Locate the Electrode Current Conduction section. From the  $\sigma_s$  list, choose User defined. In the associated text field, type `kseff_a`.
- 7- From the Effective conductivity correction list, choose No correction.

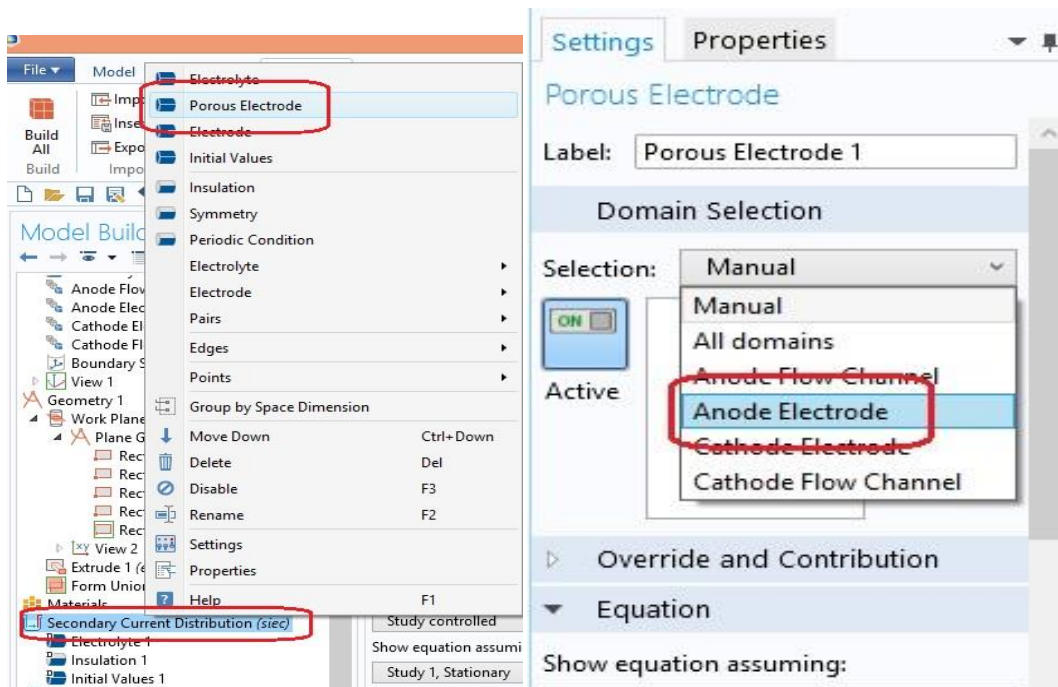

Figure 4.15 Making Porous Electrode in Model Builder window.

## **Porous Electrode Reaction 1**

1- In the Model Builder window, expand the Porous Electrode 1 node, then click Porous Electrode Reaction 1.

2- In the Settings window for Porous Electrode Reaction, locate the Model Inputs section.

3- In the T text field, type T.

4- Locate the Equilibrium Potential section. In the Eeq text field, type Eeq\_a.

The electrode current depends on the hydrogen and water concentration that are modeled by a Transport of Concentrated Species interface. The mass transport model will be set up later.

5- Locate the Electrode Kinetics section. From the Kinetics expression type list, choose Concentration dependent kinetics.

6- In the i0 text field, type i0\_a.

7- In the  $\alpha_a$  text field, type 0.5.

8- In the  $\alpha_c$  text field, type 1.5.

9- In the CR text field, type  $tcs2.c\_wH2/c\_h2ref$ .

10- In the CO text field, type  $tcs2.c\_wH2Oa/c\_h2oref$ .

11- Locate the Active Specific Surface Area section. In the av text field, type Sa\_a.

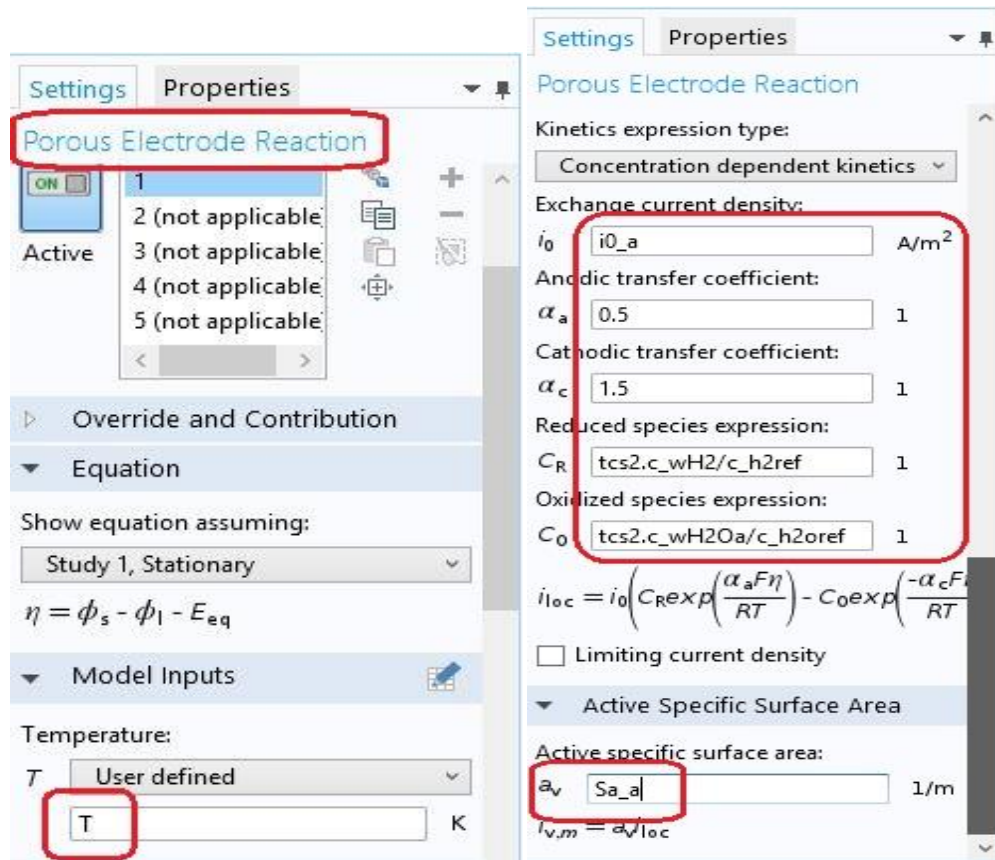

Figure 4.16 Making Porous Electrode Reaction

- **Porous Electrode 2**

- 1- On the Physics toolbar, click Domains and choose Porous Electrode.
- 2- In the Settings window for Porous Electrode, locate the Domain Selection section.
- 3- From the Selection list, choose Cathode Electrode.
- 4- Locate the Electrolyte Current Conduction section. From the  $\sigma_l$  list, choose User defined. In the associated text field, type `kleff_c`.
- 5- From the Effective conductivity correction list, choose No correction.
- 6- Locate the Electrode Current Conduction section. From the  $\sigma_s$  list, choose User defined. In the associated text field, type `kseff_c`.
- 7- From the Effective conductivity correction list, choose No correction.

- Note. these step the same as step **Porous Electrode 1**

### **Porous Electrode Reaction 1**

1- In the Model Builder window, expand the Porous Electrode 2 node, then click Porous Electrode Reaction 1.

2- In the Settings window for Porous Electrode Reaction, locate the Model Inputs section.

3- In the T text field, type T.

4- Locate the Equilibrium Potential section. In the Eeq text field, type Eeq\_c.

5- Locate the Electrode Kinetics section. From the Kinetics expression type list, choose Concentration dependent kinetics.

6- In the i0 text field, type i0\_c.

7- In the  $\alpha_a$  text field, type 3.5.

8- In the CO text field, type tcs.c\_wO2/c\_o2ref.

9. Locate the Active Specific Surface Area section. In the av text field, type Sa\_c.

- Note. These step the same as step **Porous Electrode Reaction 1**

- **Electrolyte 1**

The **Electrolyte** node defines a charge balance in the electrolyte.

1- In the Model Builder window, under Component 1 (comp1)>Secondary Current Distribution (siec) click Electrolyte 1.

2- In the Settings window for Electrolyte, locate the Electrolyte section.

3- From the  $\sigma_l$  list, choose User defined. In the associated text field, type kl.

## Electric Ground 1

Add an **Electric Ground** boundary condition from the **Electrode** submenu to set the electric potential to zero.

- 1- On the Physics toolbar, click Boundaries and choose Electric Ground.
- 2- Select Boundaries 3 and 20 only.

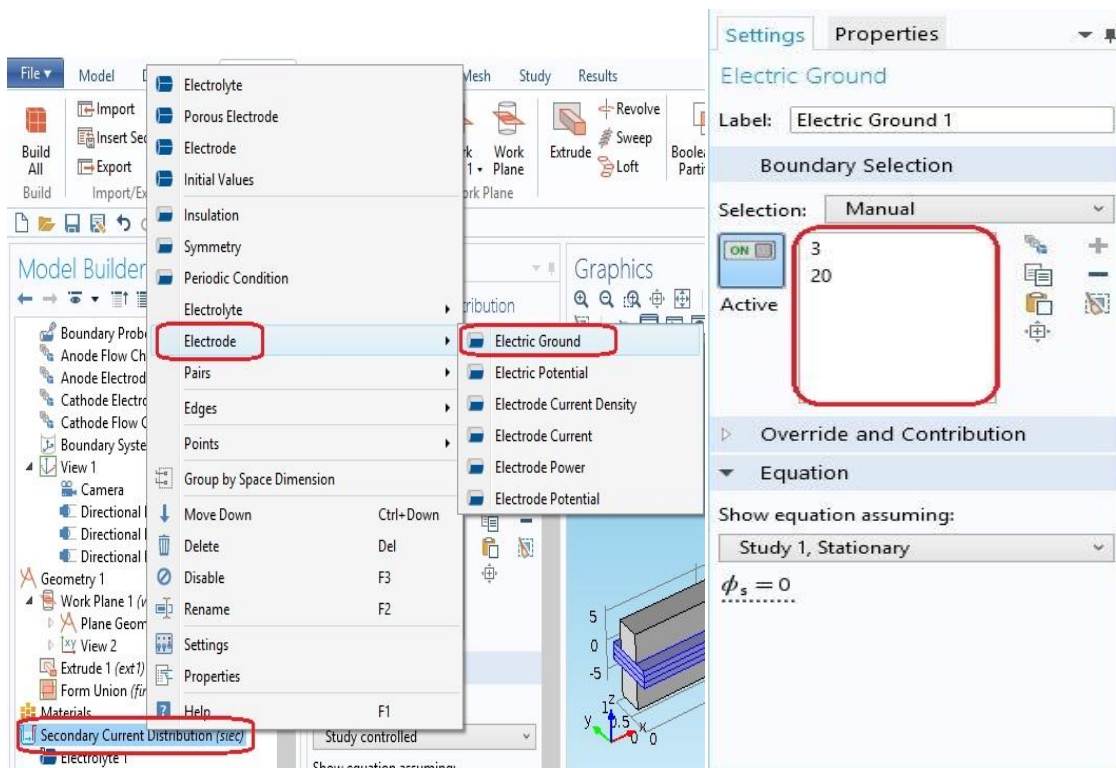

Figure 4.17 Making Electric Ground



## Electric Potential 1

Add an **Electric Potential** node from the **Electrode** submenus for boundaries, edges, and points. This feature sets the potential typically at the interface between the electrode and the current collector or current feeder.

- 1- On the Physics toolbar, click Boundaries and choose Electric Potential.
- 2- Select Boundaries 10 and 22 only.
- 3- In the Settings window for Electric Potential, locate the Electric Potential section.
- 4- In the  $\phi_{s,bnd}$  text field, type  $V_{cell}$ .

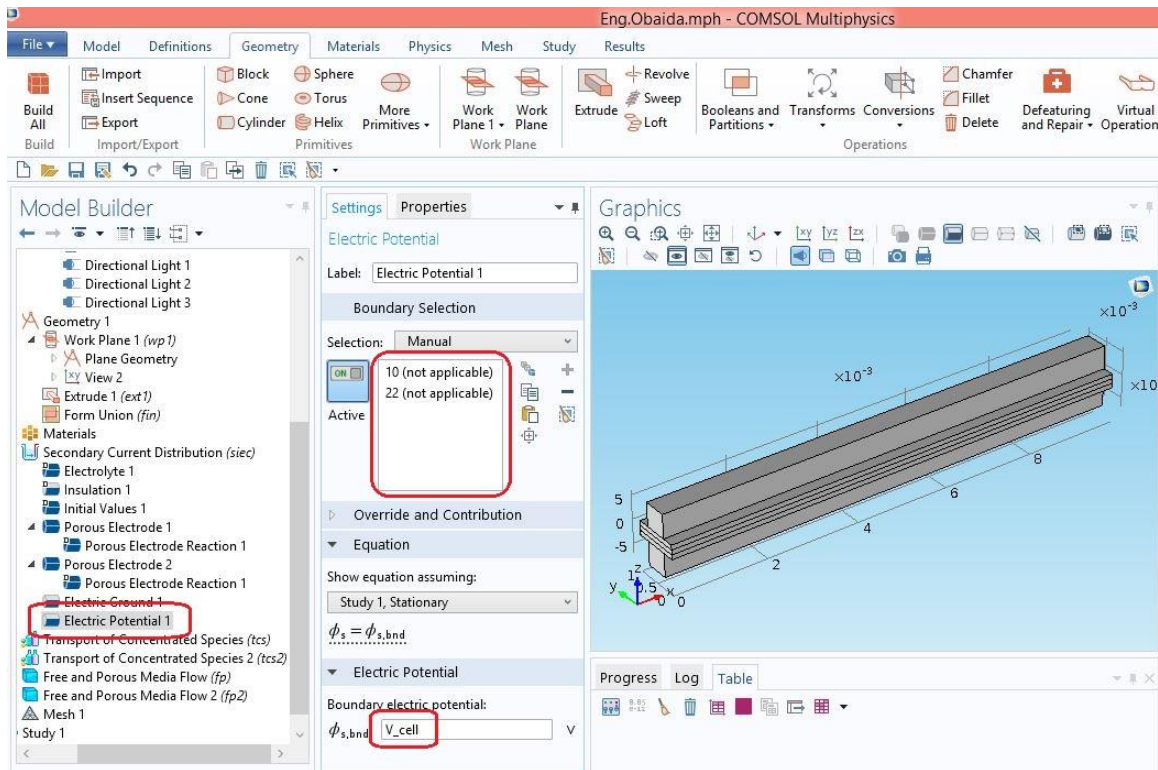

Figure 4.18 Making Electric Potential

## Initial Values 2

The **Initial Values** node sets the initial values for the electrolyte potential and the electric potential.

- 1- On the Physics toolbar, click Domains and choose Initial Values.
- 2 - Select Domain 3 only.
- 3- In the Settings window for Initial Values, locate the Initial Values section.
- 4- In the phi\_s text field, type V\_cell.

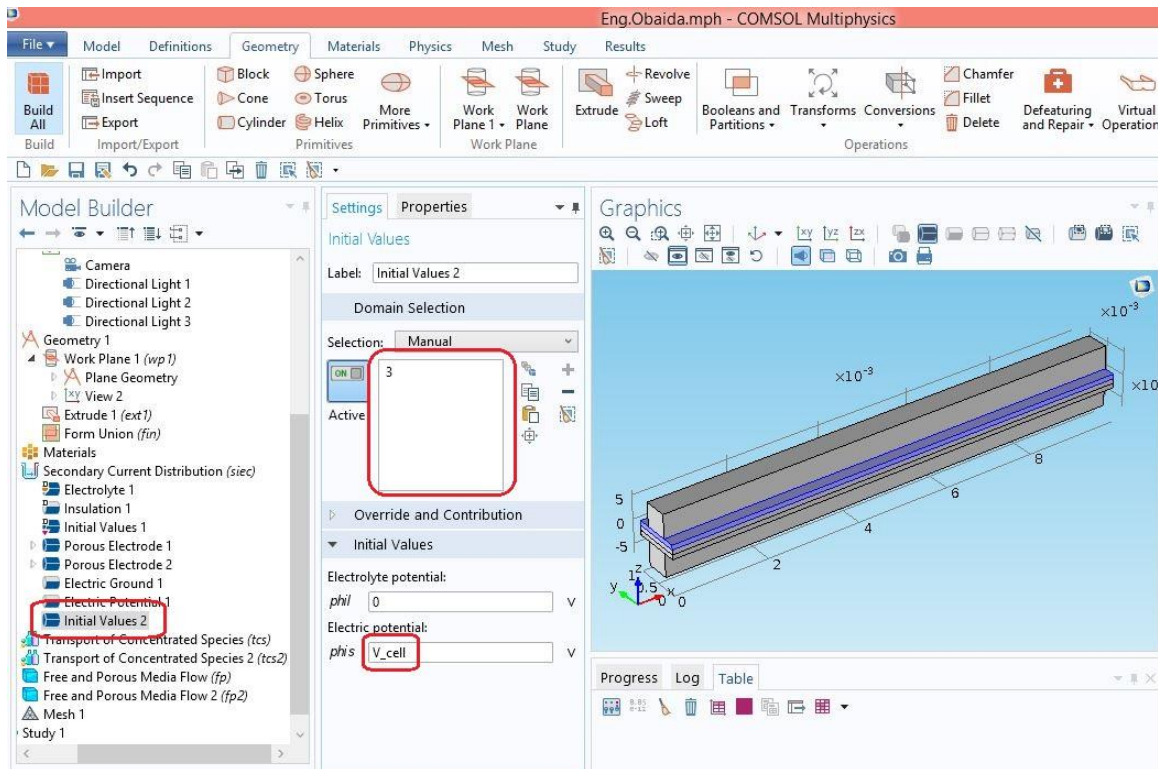

Figure 4.19 Putting Initial values

#### 4.4.2 TRANSPORT OF CONCENTRATED SPECIES (TCS)

Now set up the mass transport model on the cathode. The porous electrode reaction gives rise to a mass sink in the porous domain.

- 1- In the Model Builder window, under Component 1 (comp1) right-click Transport of Concentrated Species (tcs) and choose Rename.
- 2- In the Rename Transport of Concentrated Species dialog box, type Transport of Concentrated Species - Cathode in the New label text field.
- 3- Click OK.
- 4- Select Domains 3 and 5 only.
- 5- In the Settings window for Transport of Concentrated Species, locate the Transport Mechanisms section.
- 6- From the Diffusion model list, choose Maxwell-Stefan.
- 7- Locate the Species section. From the From mass constraint list, choose wN2.

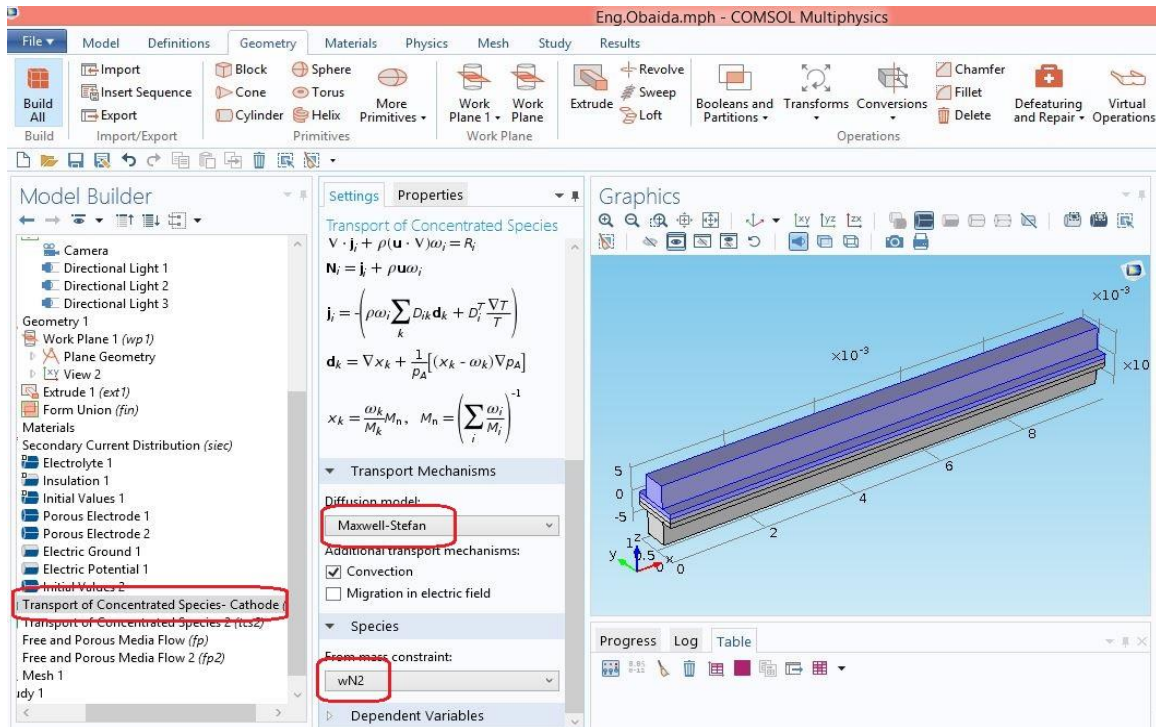

Figure 4.20 making Transport of Concentrated Species - Cathode

## Convection and Diffusion 1

The dynamic **Transport** node adds the equations for transport of concentrated species and provides inputs for the material properties. The feature name changes as the options are selected, and the node includes the input fields required by the active transport mechanisms and diffusion model

- 1- In the Model Builder window, expand the Component 1 (comp1)>Transport of Concentrated Species - Cathode (tcs) node, then click Convection and Diffusion 1.
- 2- In the Settings window for Convection and Diffusion, locate the Density section.
- 3- In the MwO2 text field, type Mo2.
- 4- In the Mwh2Oc text field, type Mh2o.
- 5- In the Mwn2 text field, type Mn2.
- 6- Locate the Diffusion section. In the Dik table, enter the following settings:

1	Do2h2oeff	Do2n2eff
Do2h2oeff	1	Dn2h2oeff
Do2n2eff	Dn2h2oeff	1

- 7- Locate the Model Inputs section. From the u list, choose Velocity field (fp/fp1).
- 8- In the T text field, type T.
- 9- From the pA list, choose Absolute pressure (fp).

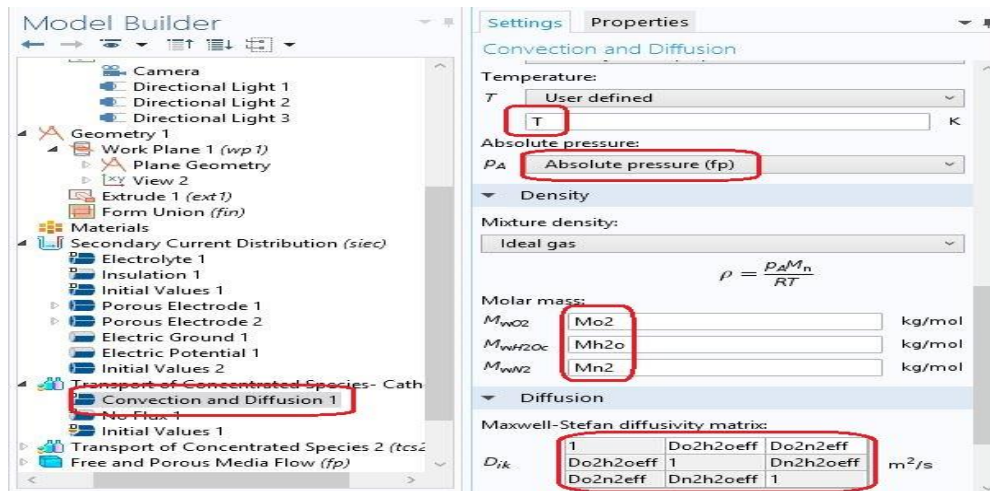

Figure 4.21 making Convection and Diffusion

### Initial Values 1

- 1- In the Model Builder window, under Component 1 (comp1)>Transport of Concentrated Species - Cathode (tcs) click Initial Values 1.
- 2- In the Settings window for Initial Values, locate the Initial Values section.
- 3- In the  $w_0, w_{O_2}$  text field, type  $w_{O_2ref}$ .
- 4- In the  $w_0, w_{H_2O}$  text field, type  $w_{H_2Oref}$ .

### Convection and Diffusion 2

- 1- On the Physics toolbar, click Domains and choose Convection and Diffusion.
- 2- In the Settings window for Convection and Diffusion, locate the Domain Selection section.
- 3- From the Selection list, choose Cathode Flow Channel.
- 4- Locate the Density section. In the  $M_{wO_2}$  text field, type  $M_{O_2}$ .
- 5- In the  $M_{wH_2O}$  text field, type  $M_{H_2O}$ .
- 6- In the  $M_{wN_2}$  text field, type  $M_{N_2}$ .

1	$D_{O_2H_2O}$	$D_{O_2N_2}$
$D_{O_2H_2O}$	1	$D_{N_2H_2O}$
$D_{O_2N_2}$	$D_{N_2H_2O}$	1

- 8- Locate the Model Inputs section. From the  $u$  list, choose Velocity field (fp/fp1).
- 9- In the  $T$  text field, type  $T$ .
- 10- From the  $p_A$  list, choose Absolute pressure (fp).

- Note. These step the same as step **Convection and Diffusion 1**

## Porous Electrode Coupling 1

- 1- On the Physics toolbar, click Domains and choose Porous Electrode Coupling.
- 2- In the Settings window for Porous Electrode Coupling, locate the Domain Selection section.
- 3- From the Selection list, choose Cathode Electrode.

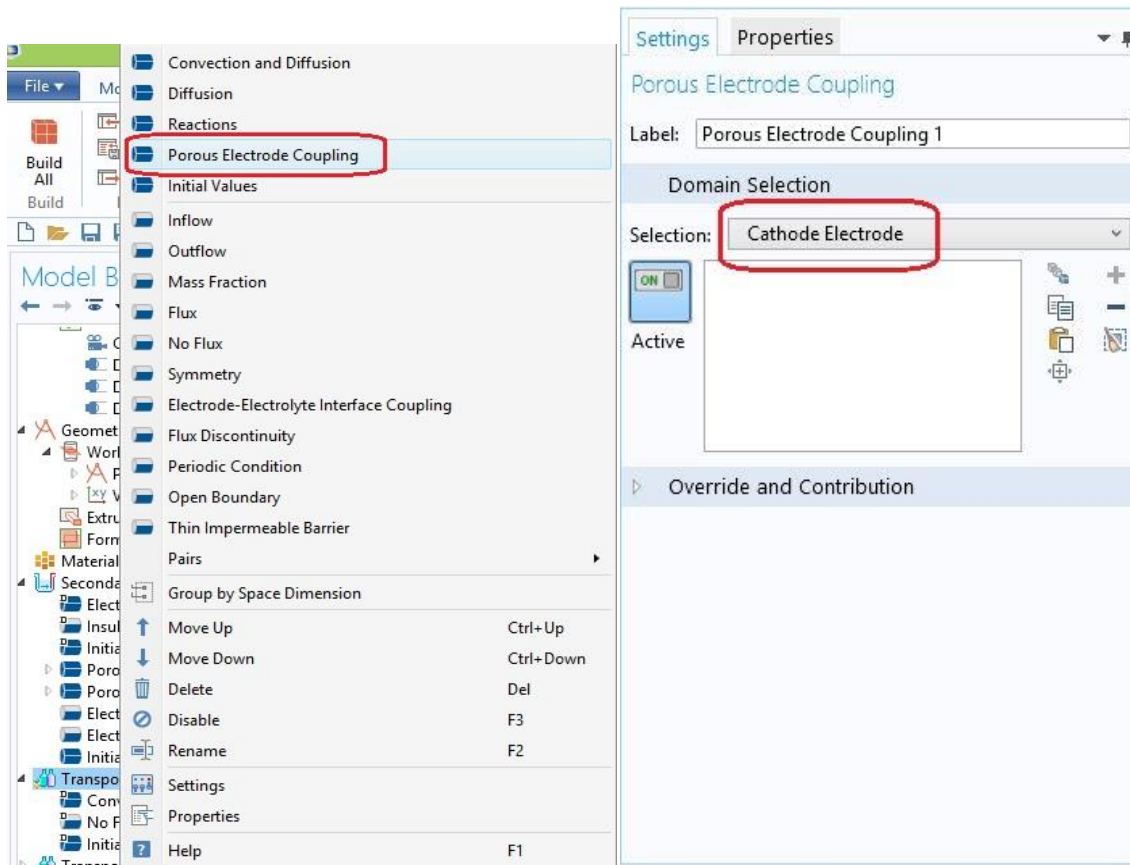

Figure 4.22 making Porous Electrode Coupling

## Reaction Coefficients 1

- 1- In the Model Builder window, expand the Porous Electrode Coupling 1 node, then click Reaction Coefficients 1.
- 2- In the Settings window for Reaction Coefficients, locate the Model Inputs section.
- 3- From the iv list, choose Local current source (siec/pce2/per1).
- 4- Locate the Stoichiometric Coefficients section. In the nm text field, type 4.
- 5- In the vwO2 text field, type -1.

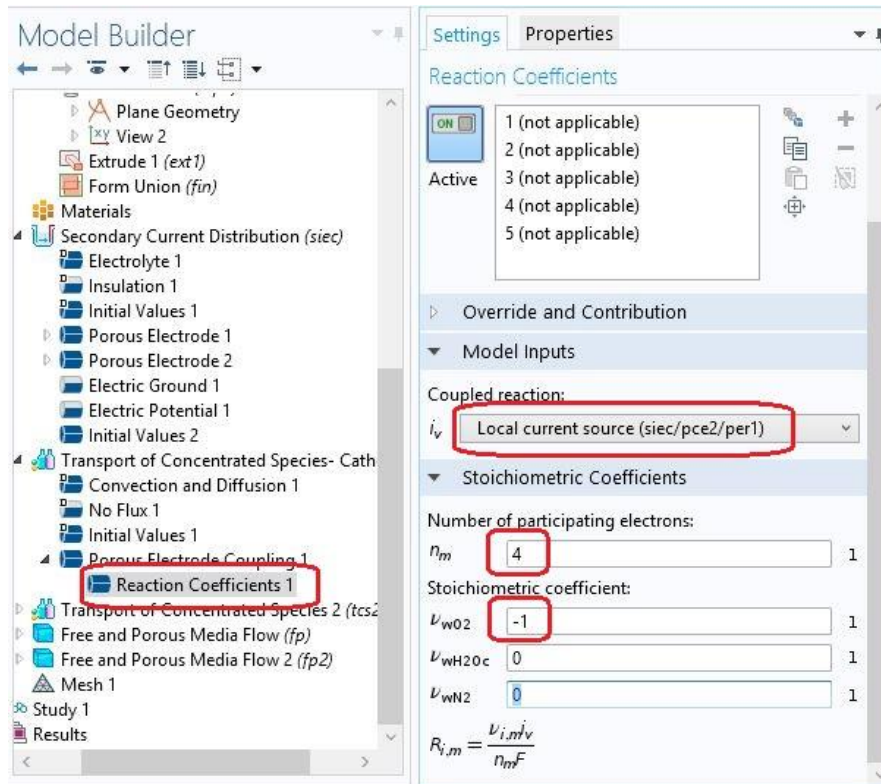

Figure 4.23 making Reaction Coefficients

## Inflow 1

- 1- On the Physics toolbar, click Boundaries and choose Inflow.
- 2- Select Boundary 30 only.
- 3- In the Settings window for Inflow, locate the Inflow section.
- 4- In the w0,wO2 text field, type w\_o2ref.
- 5- In the w0,wH2Oc text field, type w\_h2oref.

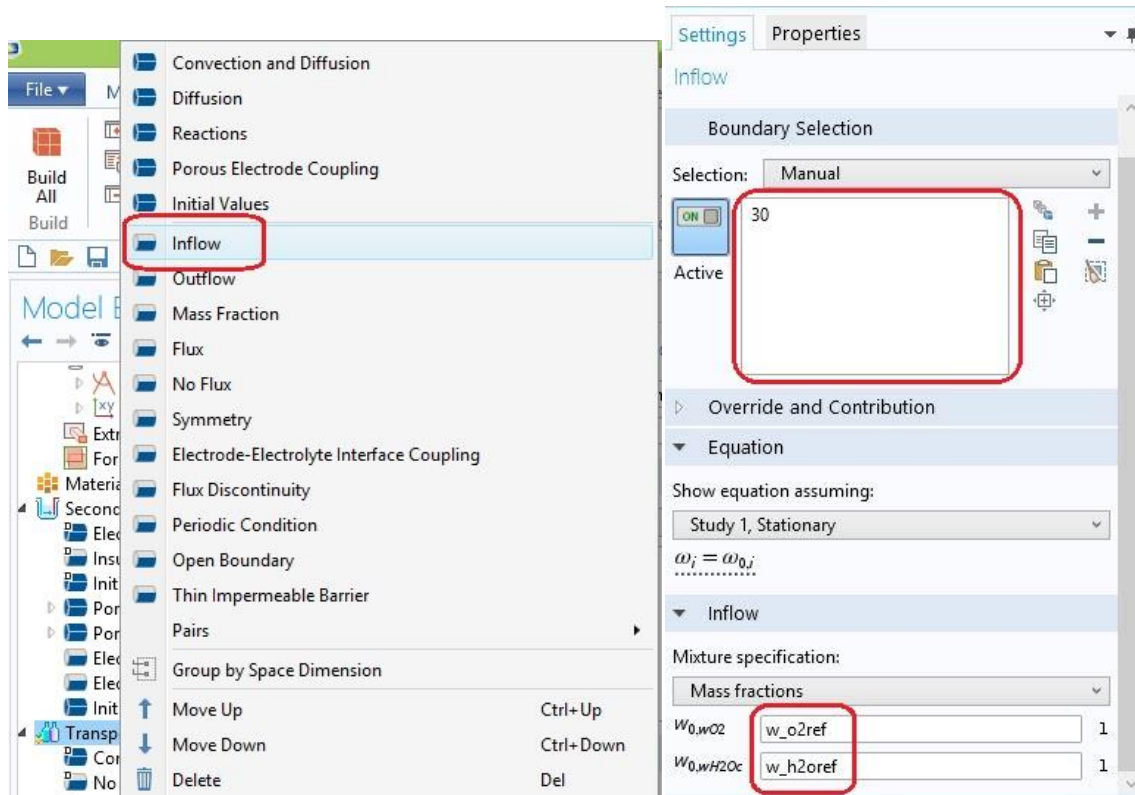

Figure 4.24 making Inflow

## Outflow 1

- 1- On the Physics toolbar, click Boundaries and choose Outflow.
- 2- Select Boundary 15 only.
  - Note. These step the same as step Inflow



### 4.4.3 TRANSPORT OF CONCENTRATED SPECIES 2 (TCS2)

Now set up the model for the mass transport on the anode side of the cell.

- 1- In the Model Builder window, under Component 1 (comp1) right-click Transport of Concentrated Species 2 (tcs2) and choose Rename.
- 2- In the Rename Transport of Concentrated Species dialog box, type Transport of Concentrated Species 2 - Anode in the New label text field.
- 3- Click OK.
- 4- Select Domains 1 and 4 only.
- 5- In the Settings window for Transport of Concentrated Species, locate the Transport Mechanisms section.
- 6- From the Diffusion model list, choose Maxwell-Stefan.
- 7- Locate the Species section. From the mass constraint list, choose wH2Oa.

- Note. These step the same as step TRANSPORT OF CONCENTRATED SPECIES 1

### Convection and Diffusion 1

- 1- In the Model Builder window, expand the Component 1 (comp1)>Transport of Concentrated Species 2 - Anode (tcs2) node, then click Convection and Diffusion 1.
- 2- In the Settings window for Convection and Diffusion, locate the Density section.
- 3- In the M<sub>wH2</sub> text field, type M<sub>h2</sub>.
- 4- In the M<sub>wH2Oa</sub> text field, type M<sub>h2o</sub>.
- 5- Locate the Diffusion section. In the Dik table, enter the following settings:

1	Dh2h2oeff
Dh2h2oeff	1

- 6- Locate the Model Inputs section. From the u list, choose Velocity field (fp2/fp1).
- 7- In the T text field, type T.
- 8- From the pA list, choose Absolute pressure (fp2).

### Initial Values 1

- 1- In the Model Builder window, under Component 1 (comp1)>Transport of Concentrated Species 2 - Anode (tcs2) click Initial Values 1.
- 2- In the Settings window for Initial Values, locate the Initial Values section.
- 3- In the  $w_0, w_{H2}$  text field, type  $w_{h2ref}$ .

### Convection and Diffusion 2

- 1- On the Physics toolbar, click Domains and choose Convection and Diffusion.
- 2- In the Settings window for Convection and Diffusion, locate the Domain Selection section.
- 3- From the Selection list, choose Anode Flow Channel.
- 4- Locate the Density section. In the  $M_{wH2}$  text field, type  $M_{h2}$ .
- 5- In the  $M_{wH2Oa}$  text field, type  $M_{h2o}$ .
- 6- Locate the Diffusion section. In the  $D_{ik}$  table, enter the following settings:

1	$D_{h2h2o}$
$D_{h2h2o}$	1

- 7- Locate the Model Inputs section. From the  $u$  list, choose Velocity field ( $fp2/fp1$ ).
- 8- In the  $T$  text field, type  $T$ .
- 9- From the  $p_A$  list, choose Absolute pressure ( $fp2$ ).

### Porous Electrode Coupling 1

- 1- On the Physics toolbar, click Domains and choose Porous Electrode Coupling.
- 2- In the Settings window for Porous Electrode Coupling, locate the Domain Selection section.
- 3- From the Selection list, choose Anode Electrode.

### **Reaction Coefficients 1**

- 1- In the Model Builder window, expand the Porous Electrode Coupling 1 node, then click Reaction Coefficients 1.
- 2- In the Settings window for Reaction Coefficients, locate the Model Inputs section.
- 3- From the iv list, choose Local current source (siec/pce1/per1).
- 4- Locate the Stoichiometric Coefficients section. In the nm text field, type 2.
- 5- In the vwH2 text field, type 1.
- 6- In the vwH2Oa text field, type -1.

### **Inflow 1**

- 1- On the Physics toolbar, click Boundaries and choose Inflow.
- 2- Select Boundary 11 only.
- 3- In the Settings window for Inflow, locate the Inflow section.
- 4- In the w0,wH2 text field, type w\_h2ref.

### **Outflow 1**

- 1- On the Physics toolbar, click Boundaries and choose Outflow.
- 2- Select Boundary 29 only.

## **4.4.4 FREE AND POROUS MEDIA FLOW (FP)**

Complete the cell model by setting up the convective flow model. The electrode reactions give rise to mass sources and sinks in the porous domains.

- 1- In the Model Builder window, under Component 1 (comp1) click Free and Porous Media Flow (fp).
- 2- Select Domains 3 and 5 only.
- 3- In the Settings window for Free and Porous Media Flow, locate the Physical Model section.

4- From the Compressibility list, choose Compressible flow (Ma<0.3).

Define the pressure reference level in the interface properties.

5- In the pref text field, type p\_atm.

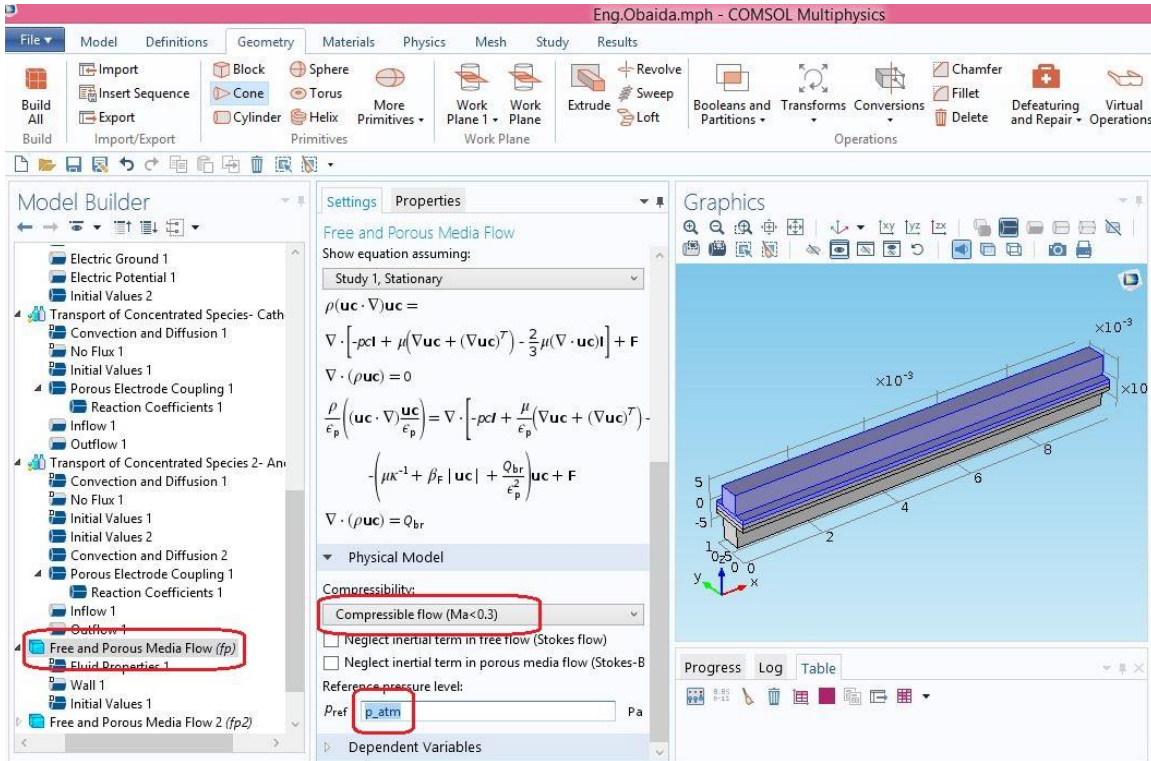

Figure 4.25 making Inflow

## Fluid Properties 1

Use the Fluid Properties node to define the fluid material, density, and dynamic viscosity.

1- In the Model Builder window, expand the Free and Porous Media Flow (fp) node, then click Fluid Properties 1.

2- In the Settings window for Fluid Properties, locate the Fluid Properties section.

3- From the  $\rho$  list, choose Density (tcs).

4- From the  $\mu$  list, choose User defined. In the associated text field, type mu.

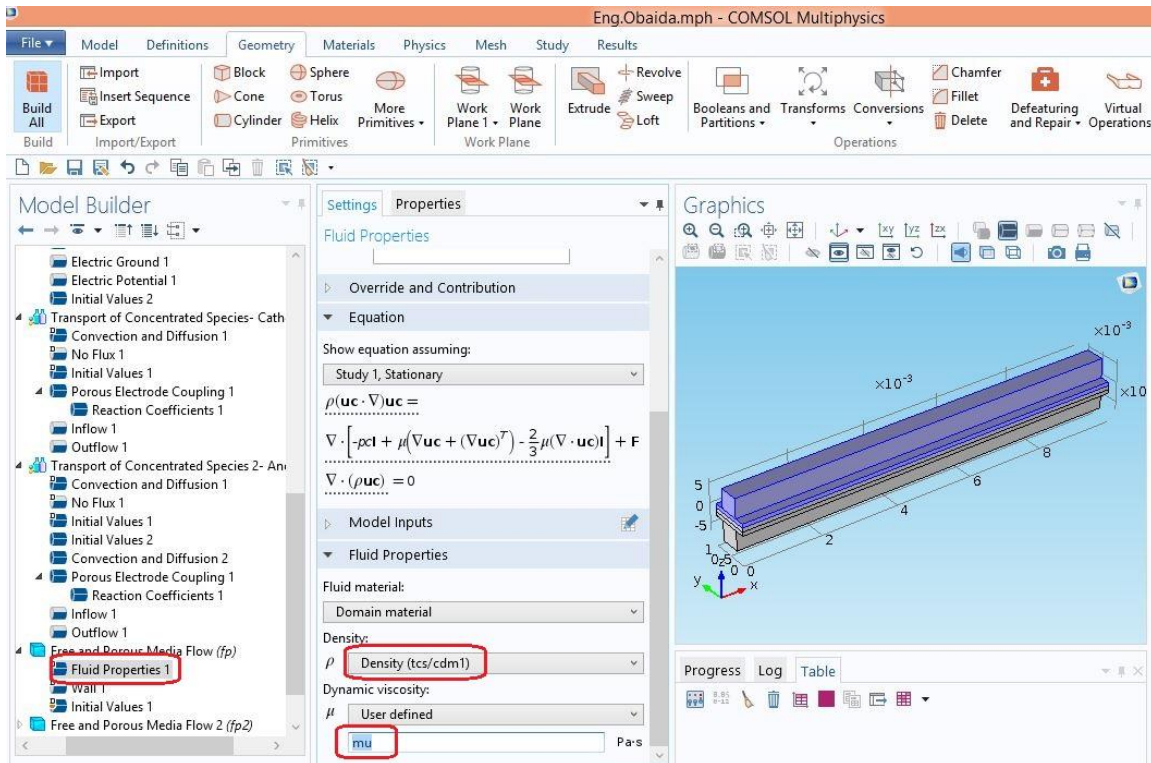

Figure 4.26 making Fluid Properties

## Porous Matrix Properties 1

- 1- On the Physics toolbar, click Domains and choose Porous Matrix Properties.
- 2- In the Settings window for Porous Matrix Properties, locate the Domain Selection section.
- 3- From the Selection list, choose Cathode Electrode.
- 4- Locate the Porous Matrix Properties section. From the  $\epsilon_p$  list, choose User defined. In the associated text field, type  $\epsilon_{por}$ .
- 5- From the  $\kappa$  list, choose User defined. In the associated text field, type  $\text{perm}_c$ .

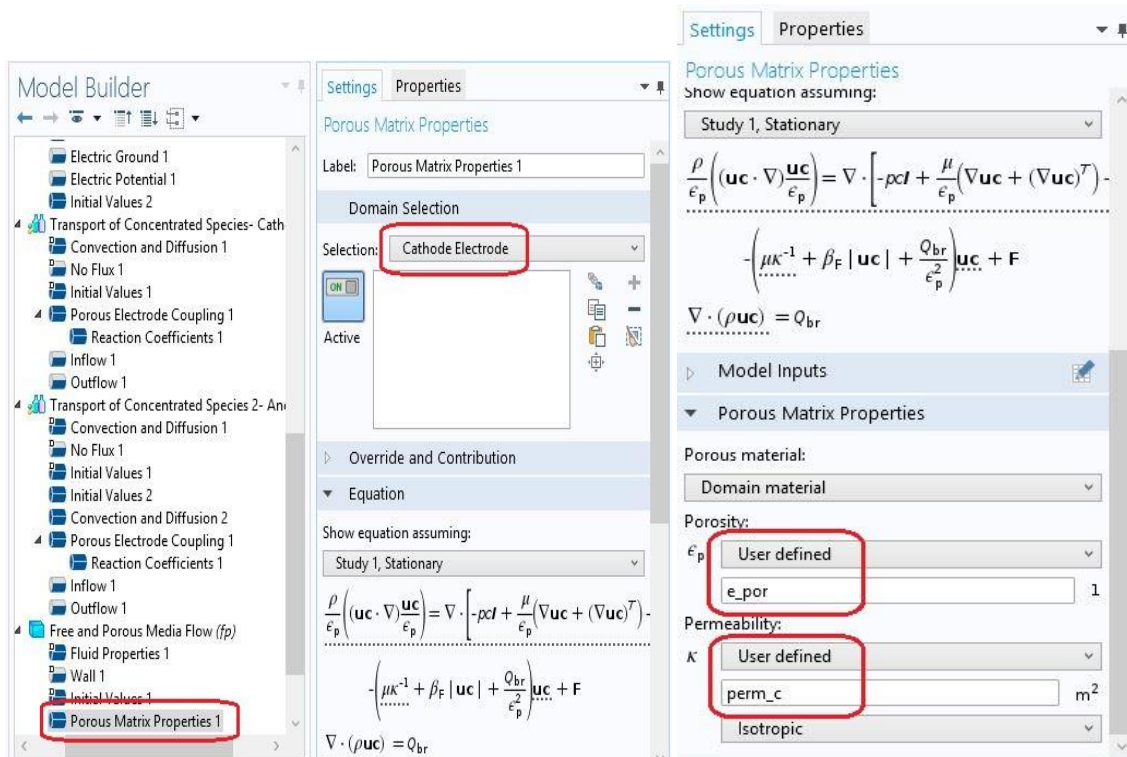

Figure 4.27 making Porous Matrix Properties

## Porous Electrode Coupling 1

Use the Porous Electrode Coupling to add a mass source in a domain that is coupled to a porous electrode reaction.

- 1- On the Physics toolbar, click Domains and choose Porous Electrode Coupling.
- 2- In the Settings window for Porous Electrode Coupling, locate the Domain Selection section.
- 3- From the Selection list, choose Cathode Electrode.
- 4- Locate the Species section. Click Add.
- 5- Click Add.
- 6- In the Species table, enter the following settings:

Species	Molar mass (kg/mol)
1	Mo2
2	Mh2o
3	Mn2

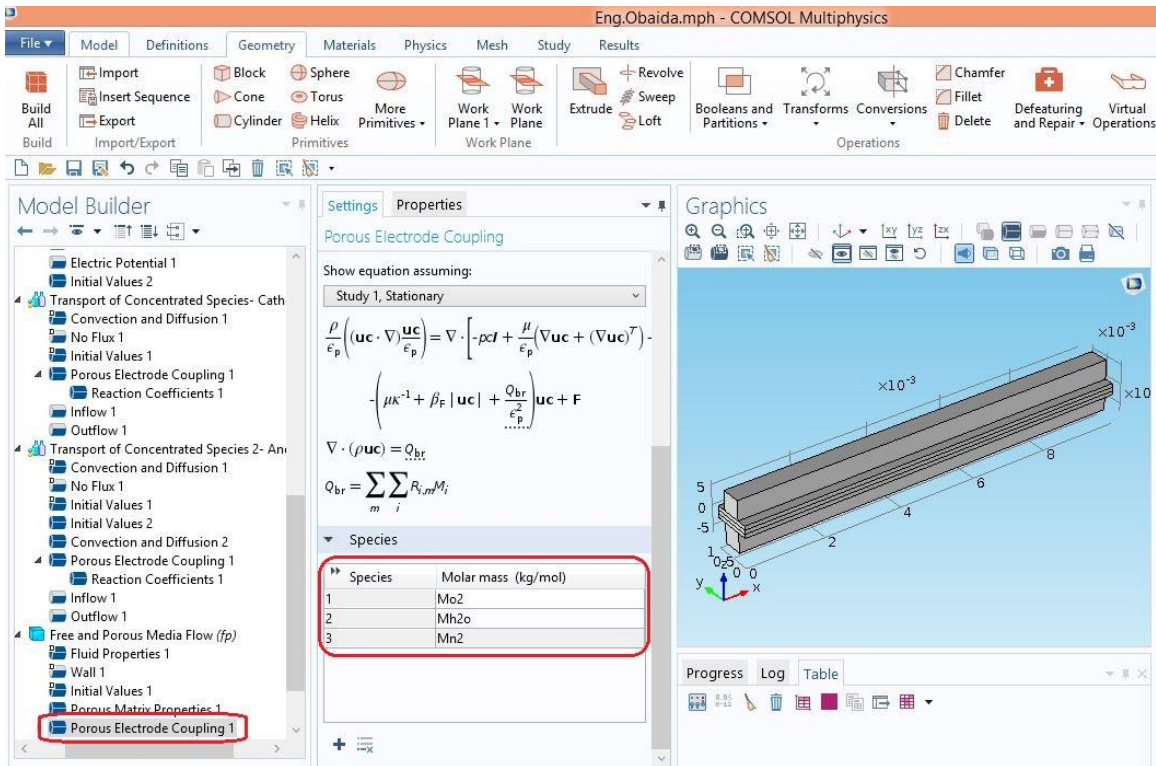

Figure 4.28 making Porous Electrode Coupling

## Reaction Coefficients 1

**Reaction Coefficients** node to the Electrode-Electrolyte Interface Coupling and Porous Electrode Coupling features to define the stoichiometric coefficients.

- 1- In the Model Builder window, expand the Porous Electrode Coupling 1 node, then click Reaction Coefficients 1.
- 2- In the Settings window for Reaction Coefficients, locate the Model Inputs section.
- 3- From the iv list, choose Local current source (siec/pce2/per1).
- 4- Locate the Stoichiometric Coefficients section. In the nm text field, type 4.
- 5- In the v1 text field, type -1.

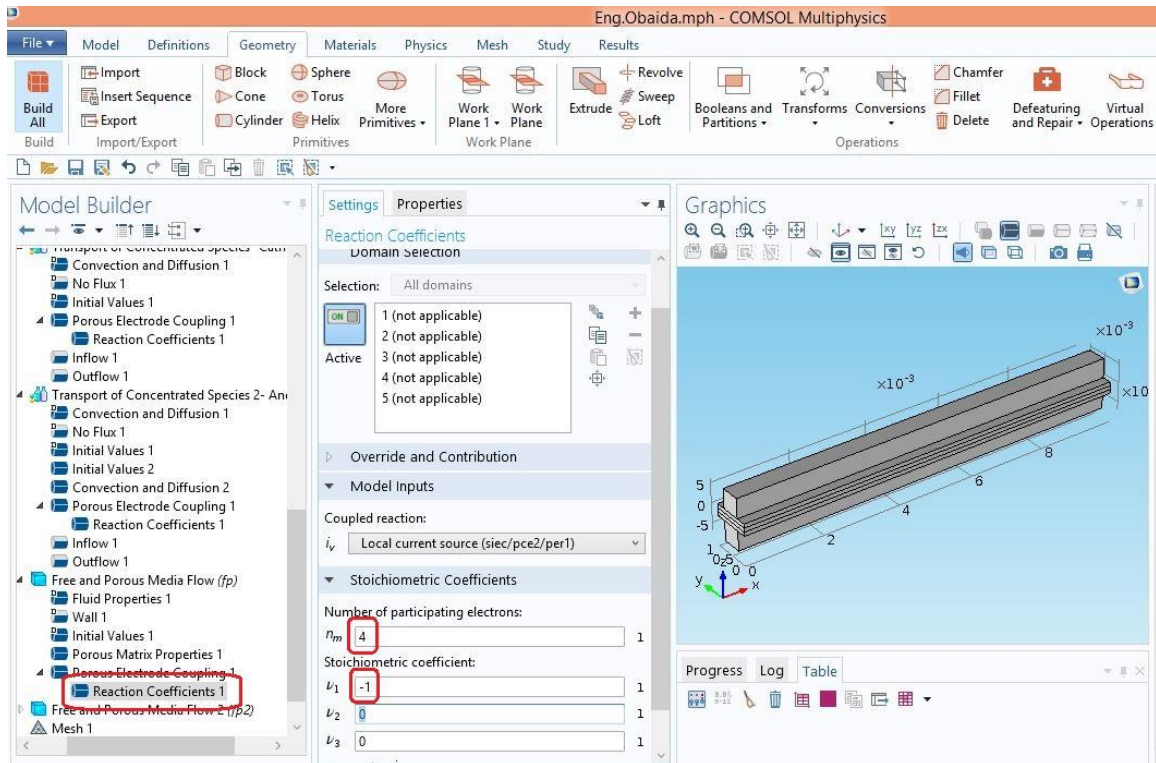

Figure 4.29 making Reaction Coefficients

### Inlet 1

- 1- On the Physics toolbar, click Boundaries and choose Inlet.
- 2- Select Boundary 30 only.
- 3- In the Settings window for Inlet, locate the Boundary Condition section.
- 4- From the list, choose Pressure.
- 5- Locate the Pressure Conditions section. In the  $p_0$  text field, type  $dp\_c$ .

### Outlet 1

- 1- On the Physics toolbar, click Boundaries and choose Outlet.
- 2- Select Boundary 15 only.
- 3- In the Settings window for Outlet, locate the Pressure Conditions section.
- 4- Select the Normal flow check box.

### Wall 2

The Wall node includes a set of boundary conditions describing the fluid-flow condition at a wall.

- 1- On the Physics toolbar, click Boundaries and choose Wall.



- 2- Select Boundaries 8 and 25 only.
- 3- In the Settings window for Wall, locate the Boundary Condition section.
- 4- From the Boundary condition list, choose Slip.

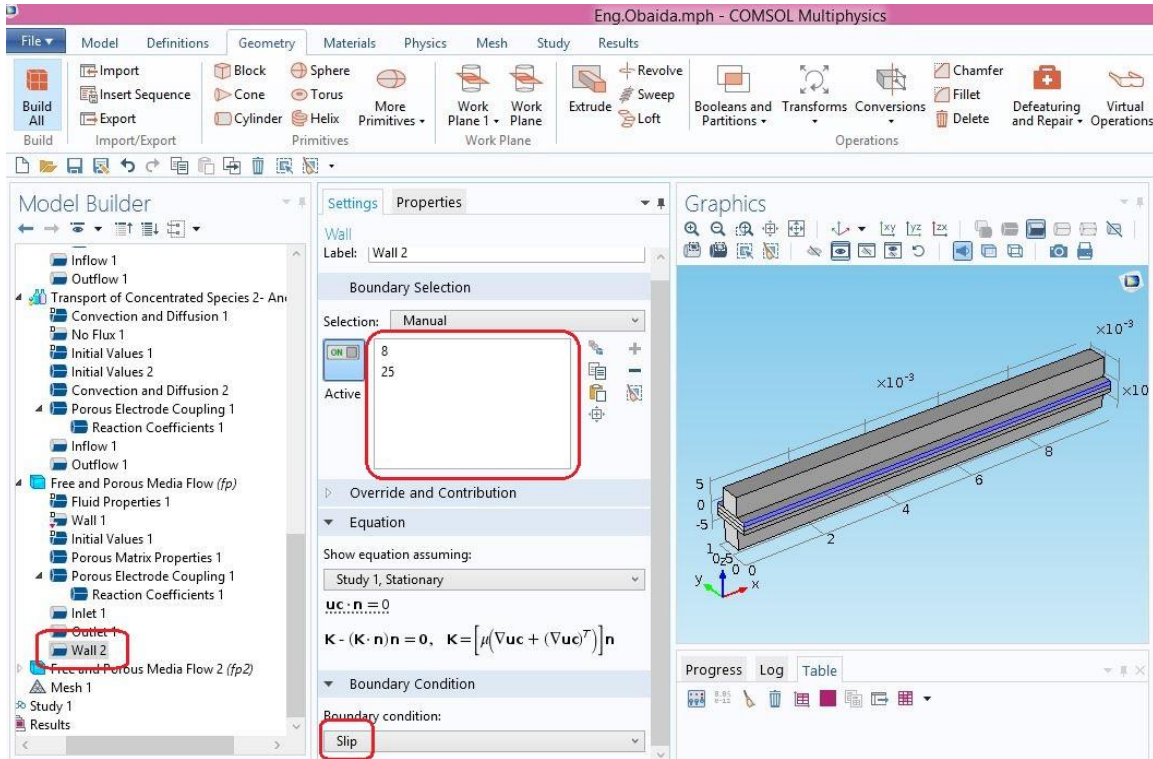

Figure 4.30 making Wall

#### 4.4.5 FREE AND POROUS MEDIA FLOW 2 (FP2)

Free and porous media flow 2 used to compute fluid velocity and pressure fields of single-phase flow where free flow is connected to porous media.

- 1- In the Model Builder window, under Component 1 (comp1) click Free and Porous Media Flow 2 (fp2).
- 2- Select Domains 1 and 4 only.
- 3- In the Settings window for Free and Porous Media Flow, locate the Physical Model section.
- 4- From the Compressibility list, choose Compressible flow (Ma<0.3).

Define the pressure reference level in the interface properties.

5- In the pref text field, type p\_atm.

### **Fluid Properties 1**

Use the **Fluid Properties** node to define the fluid material, density, and dynamic viscosity.

1- In the Model Builder window, under Component 1 (comp1)>Free and Porous Media Flow 2 (fp2) click Fluid Properties 1.

2- In the Settings window for Fluid Properties, locate the Fluid Properties section.

3- From the  $\rho$  list, choose Density (tcs2).

4- From the  $\mu$  list, choose User defined. In the associated text field, type mu.

### **Porous Matrix Properties 1**

1- On the Physics toolbar, click Domains and choose Porous Matrix Properties.

2- In the Settings window for Porous Matrix Properties, locate the Domain Selection section.

3- From the Selection list, choose Anode Electrode.

4- Locate the Porous Matrix Properties section.

From the  $\epsilon_p$  list, choose User defined. In the associated text field, type e\_por.

5- From the  $\kappa$  list, choose User defined. In the associated text field, type perm\_c.

### **Porous Electrode Coupling 1**

1- On the Physics toolbar, click Domains and choose Porous Electrode Coupling.

2- In the Settings window for Porous Electrode Coupling, locate the Domain Selection section.

3- From the Selection list, choose Anode Electrode.

4- Locate the Species section. Click Add.

5- In the Species table, enter the following settings:

Species	Molar mass (kg/mol)
1	Mh2
2	Mh2o

### **Reaction Coefficients 1**

- 1- In the Model Builder window, expand the Porous Electrode Coupling 1 node, then click Reaction Coefficients 1.
- 2- In the Settings window for Reaction Coefficients, locate the Model Inputs section.
- 3- From the iv list, choose Local current source (siec/pce1/per1).
- 4- Locate the Stoichiometric Coefficients section. In the nm text field, type 2.
- 5- In the v1 text field, type 1.
- 6- In the v2 text field, type -1.

### **Inlet 1**

- 1- On the Physics toolbar, click Boundaries and choose Inlet.
- 2- Select Boundary 11 only.
- 3- In the Settings window for Inlet, locate the Boundary Condition section.
- 4- From the list, choose Pressure.
- 5- Locate the Pressure Conditions section. In the p0 text field, type dp\_a.

### **Outlet 1**

- 1- On the Physics toolbar, click Boundaries and choose Outlet.
- 2- Select Boundary 29 only.
- 3- In the Settings window for Outlet, locate the Pressure Conditions section.
- 4- Select the Normal flow check box.

### **Wall 2**

- 1- On the Physics toolbar, click Boundaries and choose Wall.
- 2- Select Boundaries 2 and 23 only.
- 3- In the Settings window for Wall, locate the Boundary Condition section.
- 4- From the Boundary condition list, choose Slip.

## 4.5 MESH 1

The physics settings for the model is now complete. A mapped mesh, swept in the channel direction, is suitable for this geometry. Control the size in the y direction by using an individual Edge node.

### Edge 1

Add an **Edge** node (  ) to mesh edges. You can control the number of elements and the distribution of elements in the edge mesh by using Size and Distribution nodes.

1- In the Model Builder window, under Component 1 (comp1) right-click Mesh 1 and choose More Operations>Edge.

2- Select Edges 2, 10, 15, 18, 24, and 27 only.

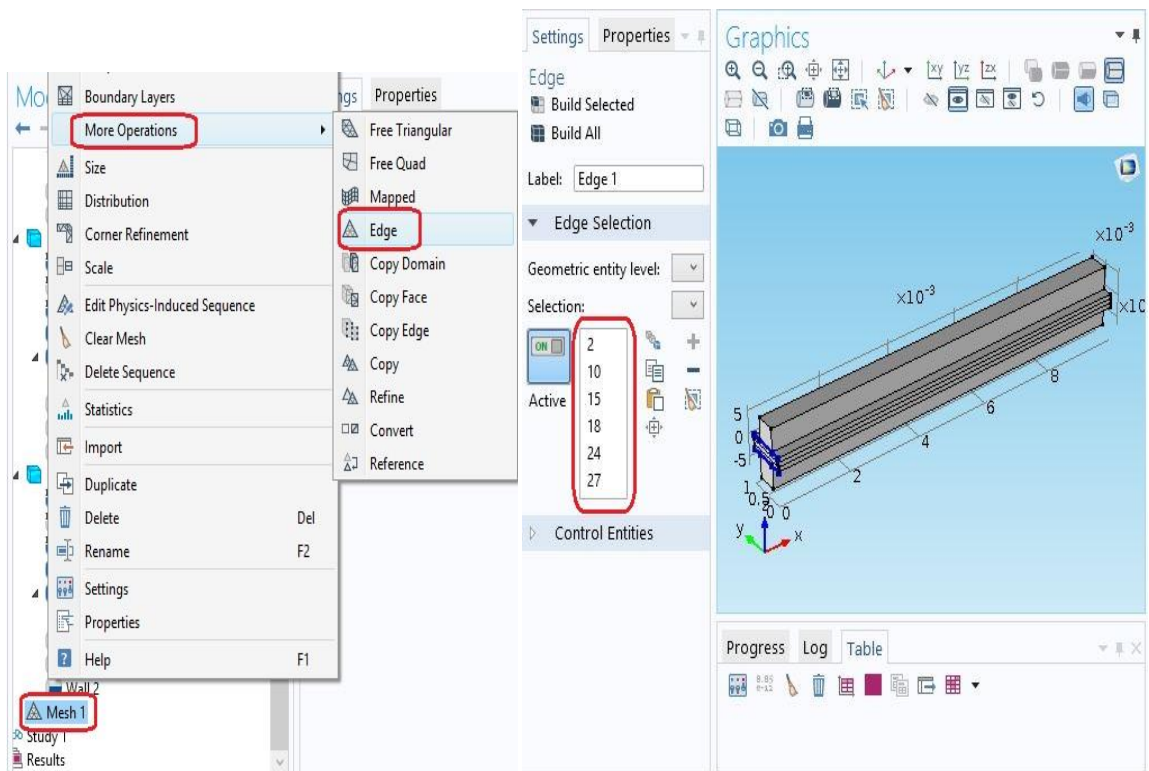

Figure 4.31 making Edge

## Size 1

- 1- Right-click Component 1 (comp1)>Mesh 1>Edge 1 and choose Size.
- 2- In the Settings window for Size, locate the Element Size section.
- 3- Click the Custom button.
- 4- Locate the Element Size Parameters section. Select the Maximum element size check box.
- 5- In the associated text field, type  $W\_channel/8$ .
- 6- Click the Build Selected button.

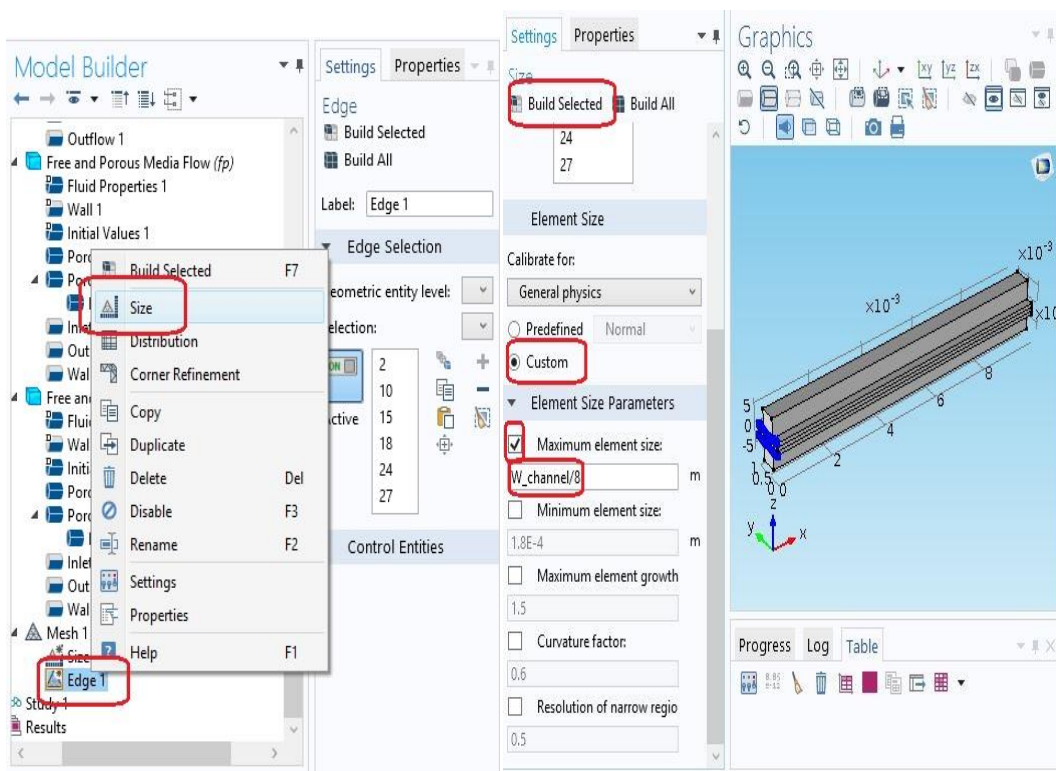

Figure 4.32 making size

## Mapped 1

- 1- In the Model Builder window, right-click Mesh 1 and choose More Operations>Mapped.
- 2- Select Boundaries 1, 4, 7, 11, and 15 only.

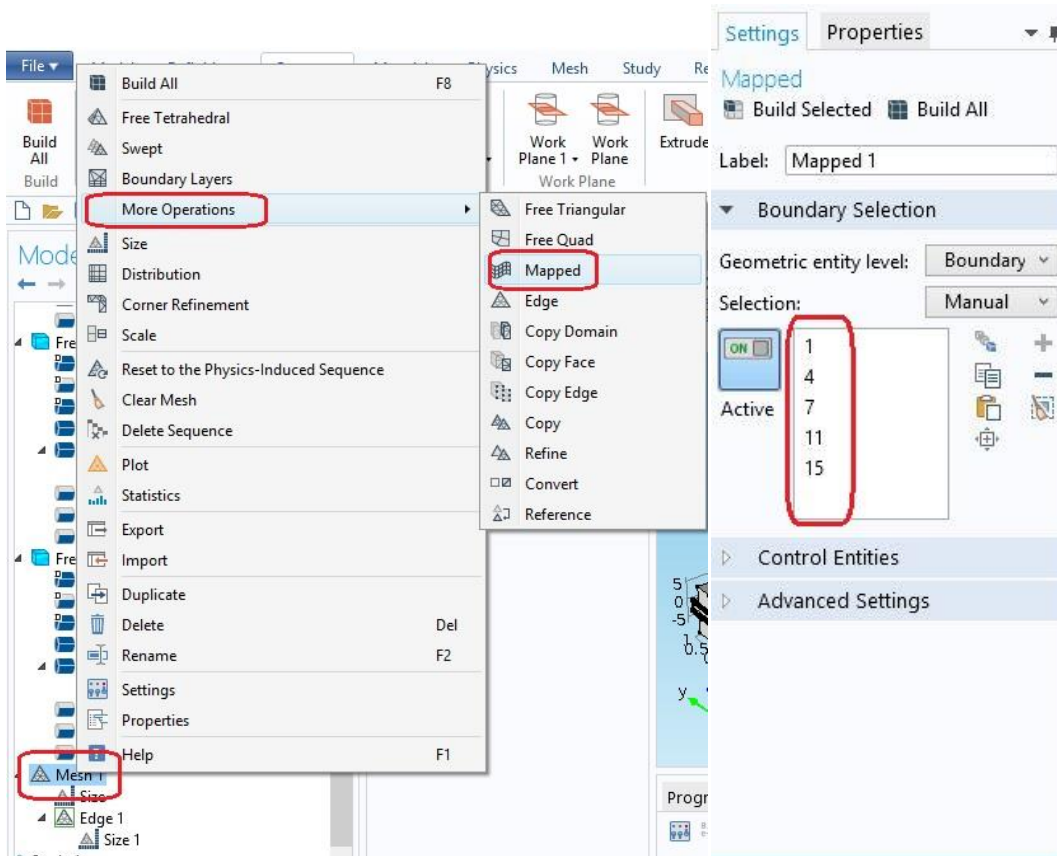

Figure 4.33 making Mapped

## Distribution 1

- 1- Right-click Component 1 (comp1)>Mesh 1>Mapped 1 and choose Distribution.
- 2- Select Edges 12, 17, 22, and 26 only.
- 3- In the Settings window for Distribution, locate the Distribution section.
- 4- From the Distribution properties list, choose Predefined distribution type.
- 5- In the Number of elements text field, type 10.
- 6- In the Element ratio text field, type 3.
- 7- Select the Symmetric distribution check box.

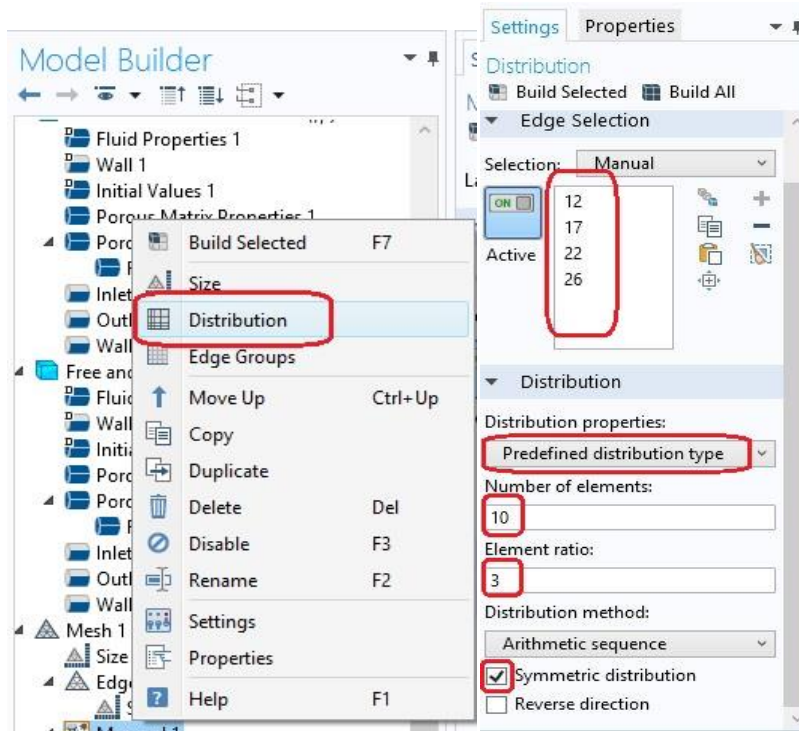

Figure 4.34 making Distribution

### Distribution 2

- 1- Right-click Mapped 1 and choose Distribution.
- 2- Select Edges 7 and 34 only.
- 3- In the Settings window for Distribution, locate the Distribution section.
- 4- From the Distribution properties list, choose Predefined distribution type.
- 5- In the Number of elements text field, type 8.
- 6- In the Element ratio text field, type 3.

### Distribution 3

- 1- Right-click Component 1 (comp1)>Mesh 1>Mapped 1>Distribution 2 and choose Duplicate.
- 2- In the Settings window for Distribution, locate the Edge Selection section.
- 3- Click Clear Selection.
- 4- Select Edges 1 and 30 only.

5- Locate the Distribution section. Select the Reverse direction check box.

#### Distribution 4

1- In the Model Builder window, under Component 1 (comp1)>Mesh 1 right-click Mapped and choose Distribution.

2- Select Edges 4 and 32 only.

3- In the Settings window for Distribution, locate the Distribution section.

4- In the Number of elements text field, type 3.

- Note. These step the same as step Distribution 1

#### Mapped 1

Right-click Mapped 1 and choose Build Selected.

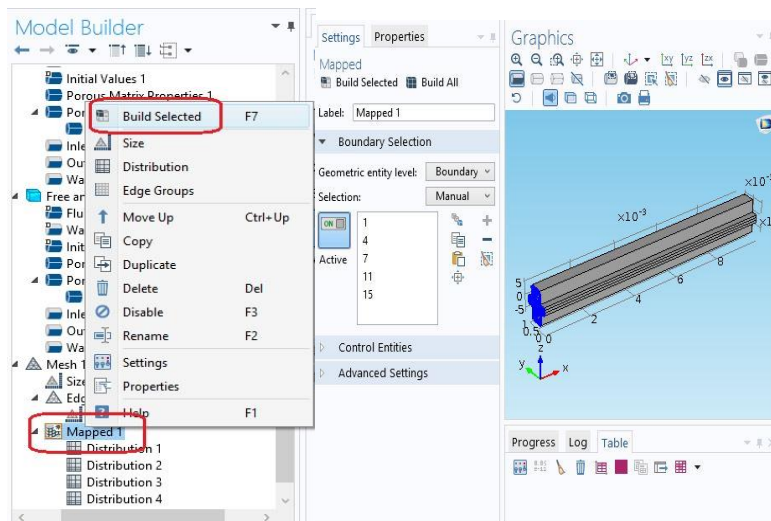



Figure 4.35 making Mapped Build Selected

#### Swept 1

The **Swept** node (  ) creates a swept mesh on a domain in 3D by sweeping the mesh from the source face along the domain to an opposite destination face. The source and destination can consist of several connected faces.

Right-click Mesh 1 and choose Swept



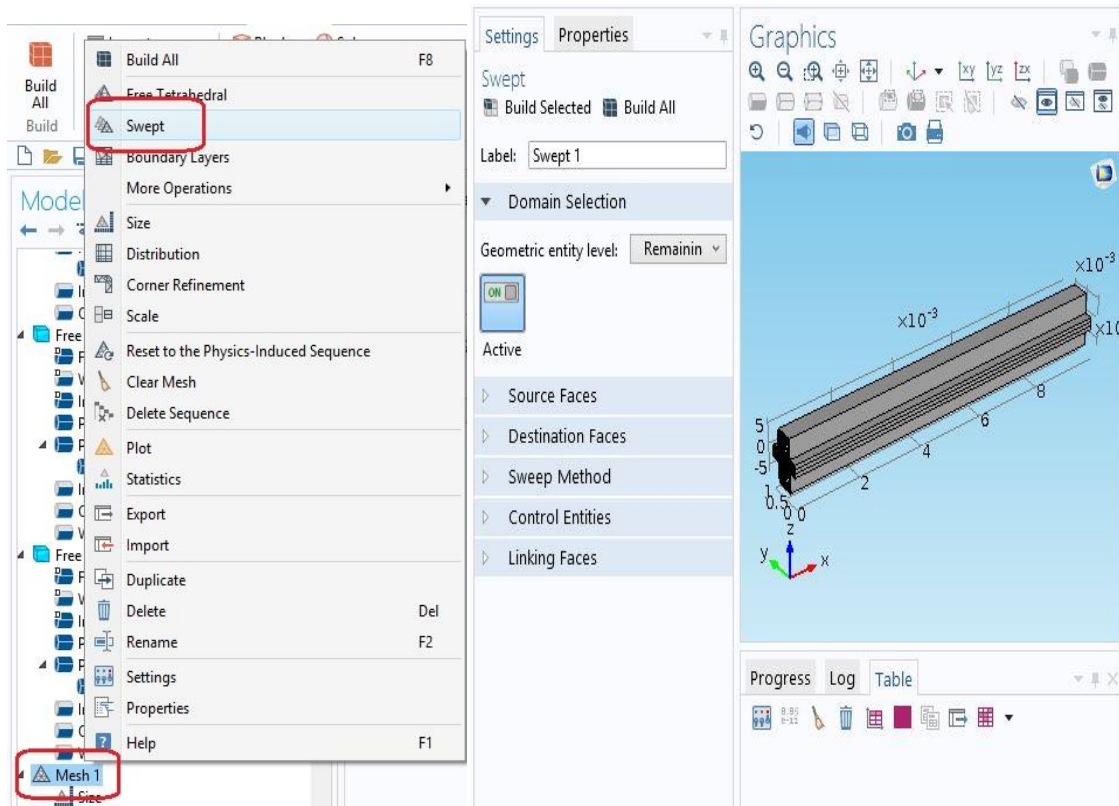



Figure 4.36 making Swept 1

## Size 1

Use a **Size** node (  ) to specify the size of mesh elements.

- 1- In the Model Builder window, under Component 1 (comp1)>Mesh 1 right-click Swept 1 and choose Size.
- 2- In the Settings window for Size, locate the Element Size section.
- 3- Click the Custom button.
- 4- Locate the Element Size Parameters section. Select the Maximum element size check box.
- 5- In the associated text field, type W\_channel.
- 6- Click the Build All button.

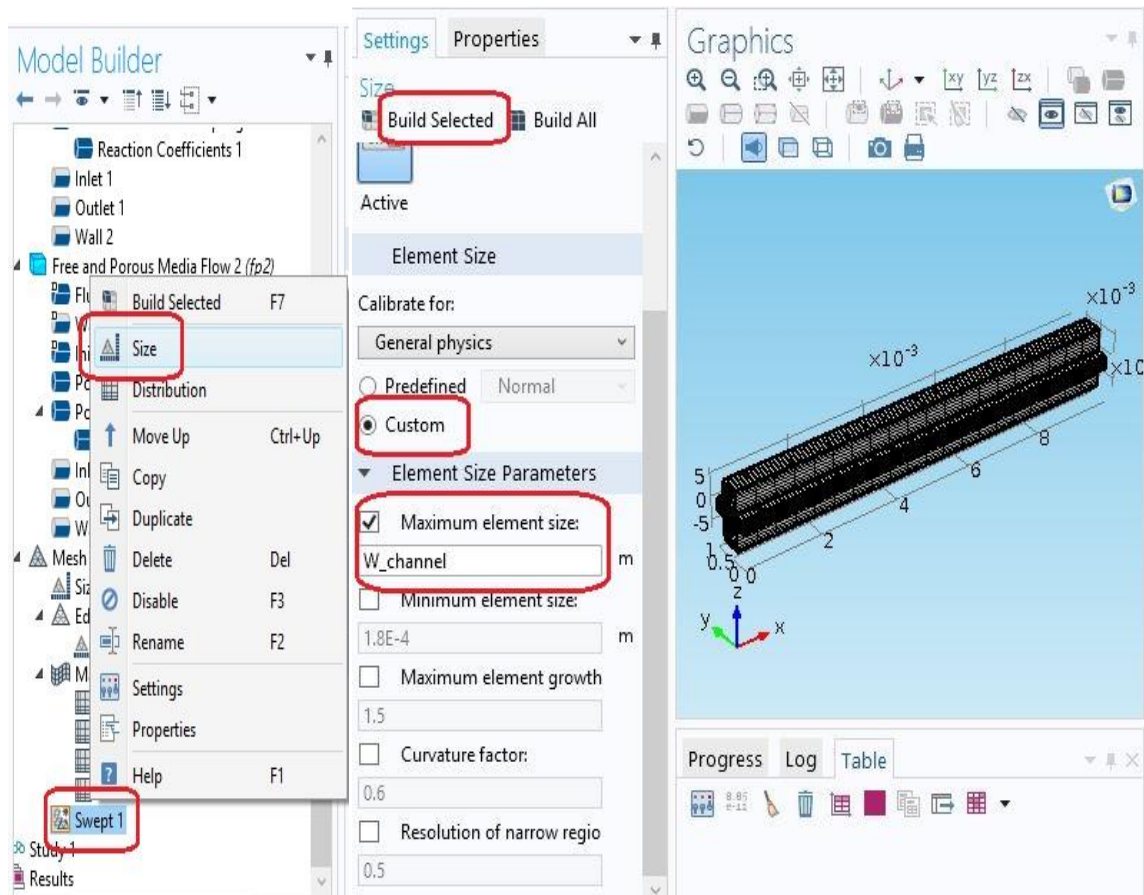



Figure 4.37 making Size

## 4.6 STUDY

A **Study** node (  ) holds the all the nodes that define how to solve a model.

Use an auxiliary sweep with continuation to solve for a range of different cell polarization voltages.

### Step 1: Stationary

1- In the Model Builder window, under Study 1 click Step 1: Stationary.

2- In the Settings window for Stationary, click to expand the Study extensions section.

3- Locate the Study Extensions section. Select the Auxiliary sweep check box.

4- Click Add.

5- In the table, enter the following settings:

Parameter name	Parameter value list	Parameter unit
V_pol	0.05 range(0.1,0.1,0.8)	

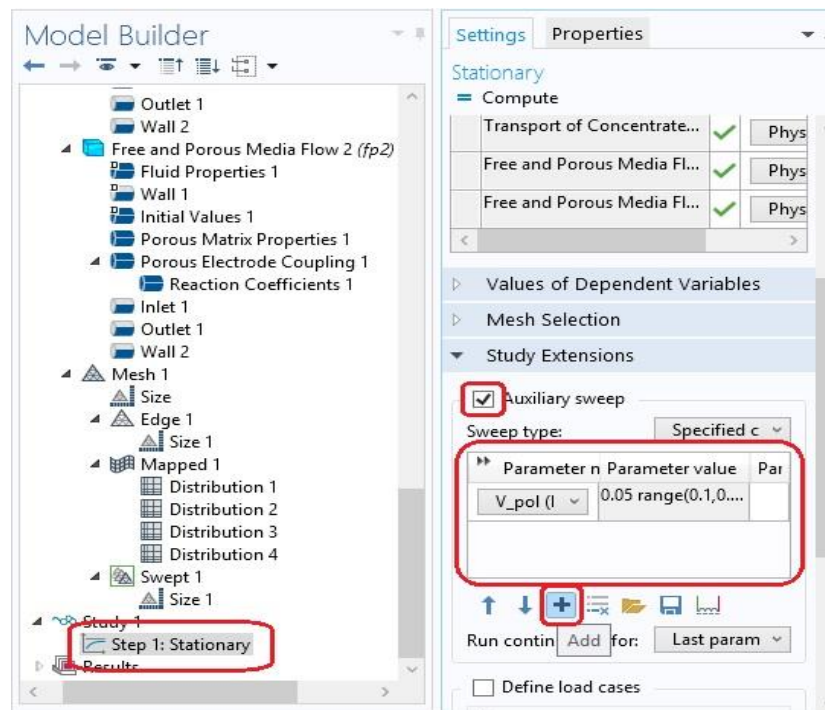

Figure 4.38 making Size Stationary

6- In the Model Builder window, click Study 1.

7- In the Settings window for Study, locate the Study Settings section.

8- Clear the Generate default plots check box.

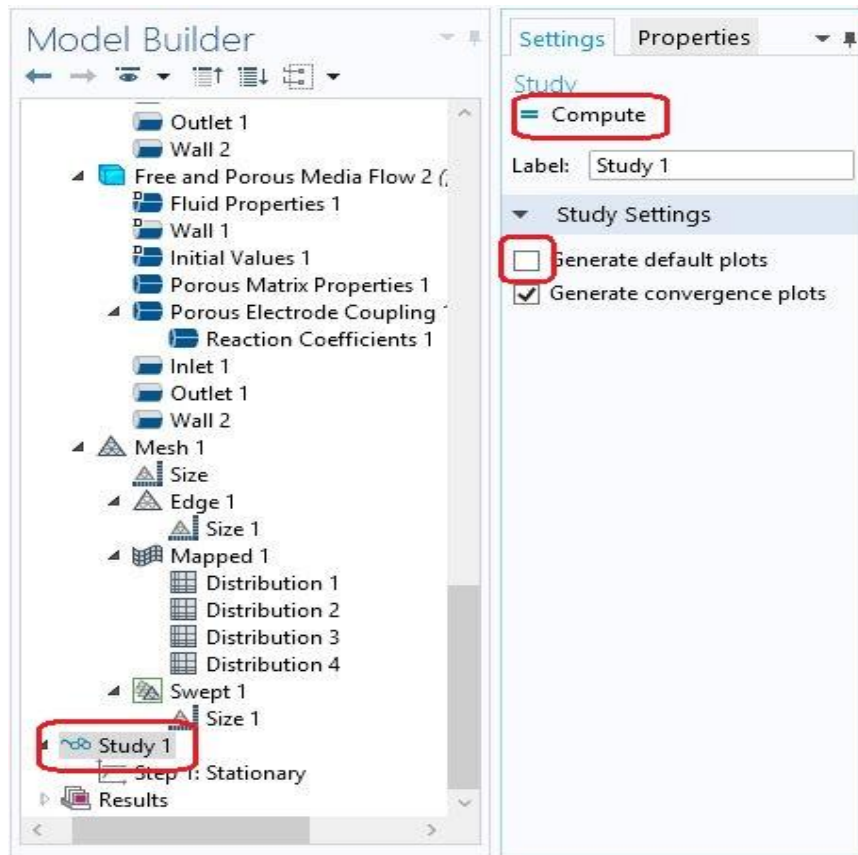

Figure 4.39 making Study

9. On the Model toolbar, click Compute.

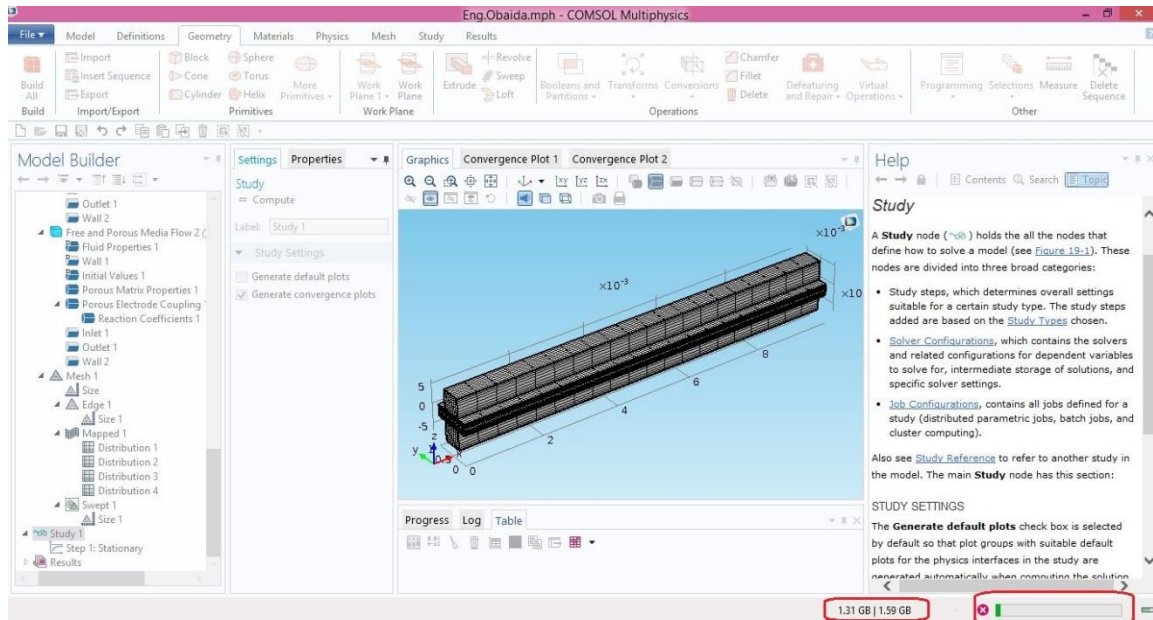

Figure 4.40 making Compute Study

## 4.7 RESULTS

The **Results** branch contains tools and functionality for post processing and visualizing of the results. The main **Results** node contains all nodes that you create for such purposes.

Derived Values

Follow these instructions to reproduce the plot in Figure 41 of the oxygen distribution in the anode at a cell voltage of 0.5 V.

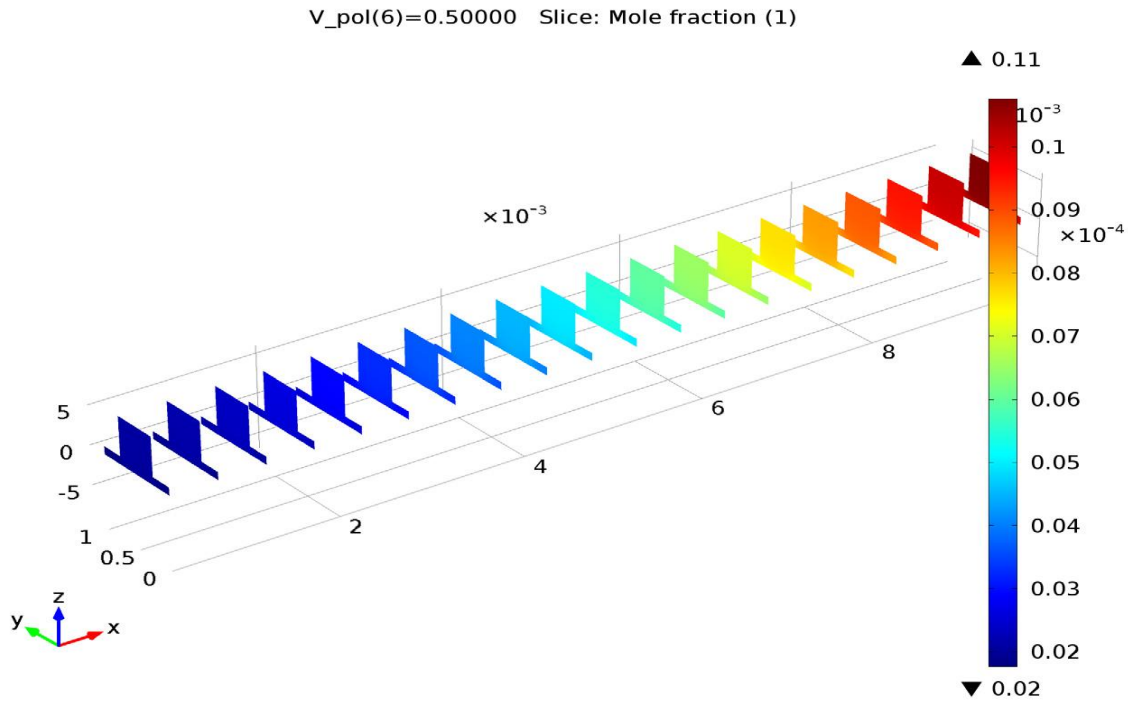

Figure 4.41 Oxygen mole fraction in the gas channel and in the gas diffusion cathode while operating at a cell voltage of 0.5 V.

### 3D Plot Group 2

- 1- On the Model toolbar, click Add Plot Group and choose 3D Plot Group.
- 2- In the Settings window for 3D Plot Group, locate the Data section.
- 3- From the Parameter value ( $V_{pol}$ ) list, choose 0.50000.
- 4- Locate the Plot Settings section. Clear the Plot data set edges check box.
- 5- Right-click Results>3D Plot Group 2 and choose Slice.
- 6- In the Settings window for Slice, click Replace Expression in the upper-right corner of the Expression section. From the menu, choose Component 1>Transport of Concentrated Species - Cathode>Species wO2>tcs.x\_wO2 - Mole fraction.
- 7- Locate the Plane Data section. In the Planes text field, type 20.
- 8- On the 3D plot group toolbar, click Plot.

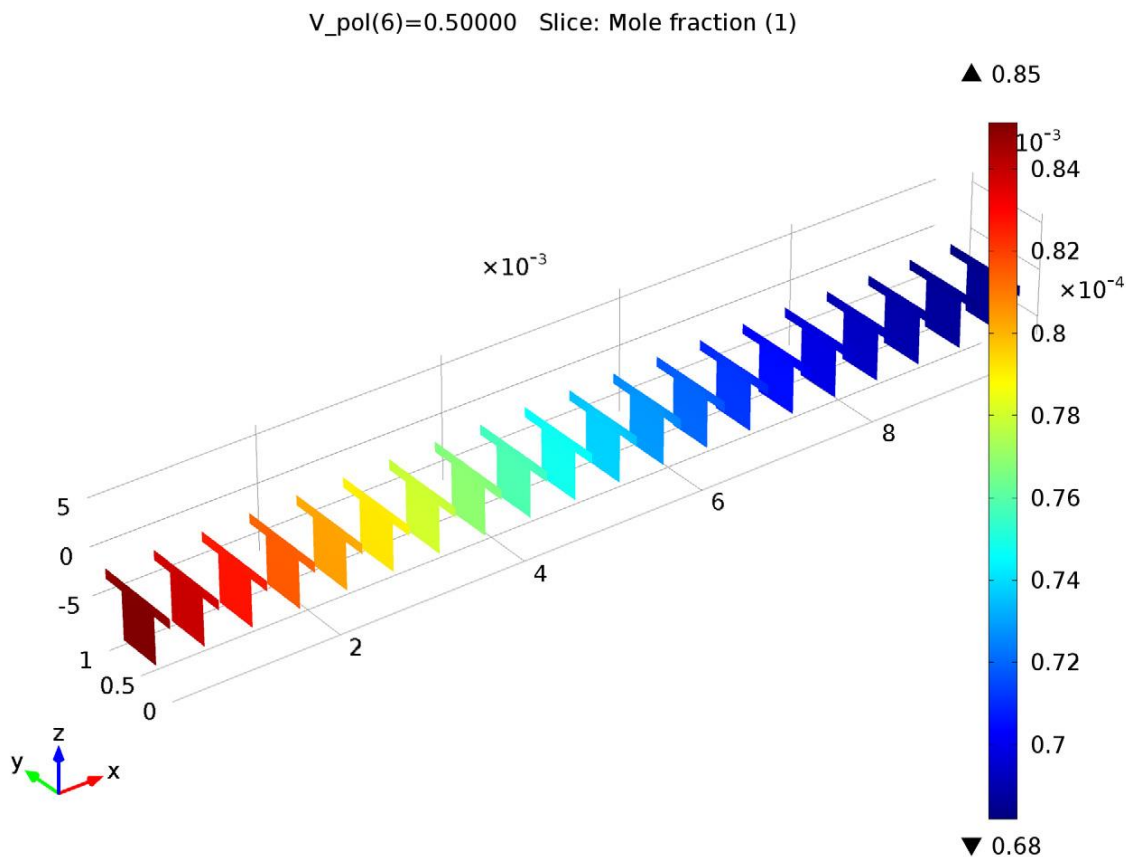

Figure 4.42 Hydrogen distribution in the anode at 0.5 V cell voltage.

### 3D Plot Group 3

- 1- On the Model toolbar, click Add Plot Group and choose 3D Plot Group.
- 2- In the Settings window for 3D Plot Group, locate the Data section.
- 3- From the Parameter value ( $V_{pol}$ ) list, choose 0.50000.
- 4- Locate the Plot Settings section. Clear the Plot data set edges check box.
- 5- Right-click Results>3D Plot Group 3 and choose Slice.
- 6- In the Settings window for Slice, click Replace Expression in the upper-right corner of the Expression section. From the menu, choose Component 1>Transport of Concentrated Species 2 - Anode>Species wH2>tcs2.x\_wH2 - Mole fraction.
- 7- Locate the Plane Data section. In the Planes text field, type 20.
- 8- On the 3D plot group toolbar, click Plot.

The following instructions reproduce the plot of the polarization curve for the SOFC (see Figure 5.43).

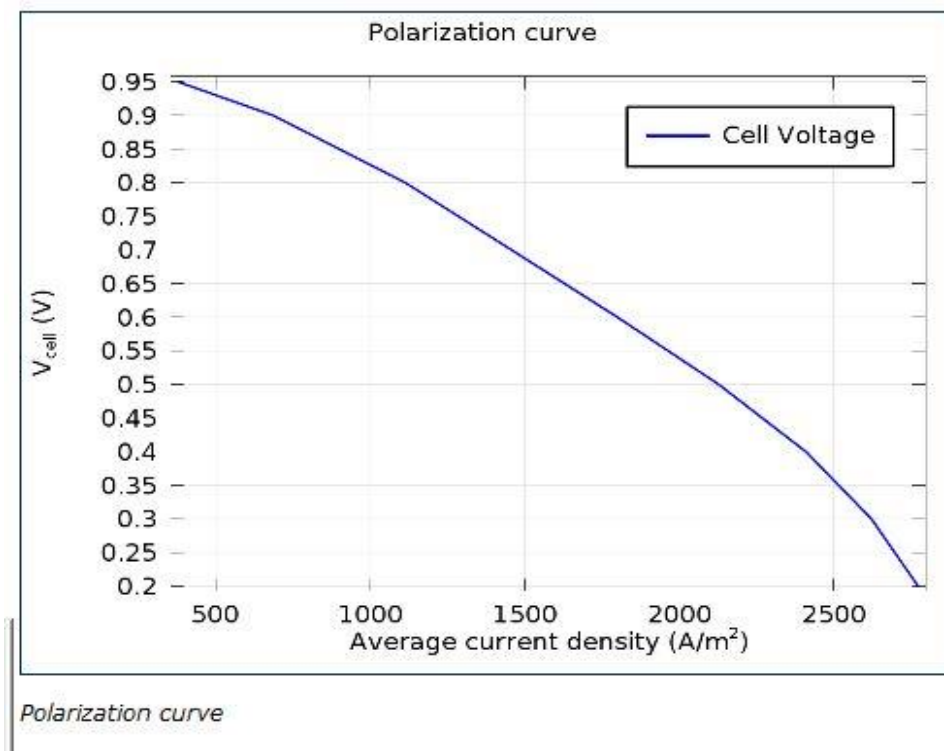

Figure 4.43 shows the voltage as a function of the total current (polarization curve).



#### 1D Plot Group 4

- 1- On the Model toolbar, click Add Plot Group and choose 1D Plot Group.
- 2- In the Settings window for 1D Plot Group, click to expand the Title section.
- 3- From the Title type list, choose Manual.
- 4- In the Title text area, type Polarization curve.
- 5- Locate the Plot Settings section. Select the x-axis label check box.
- 6- In the associated text field, type Average current density ( $A/m^2$ ).
- 7- Select the y-axis label check box.
- 8- In the associated text field, type  $V_{cell}$  (V).
- 9- On the 1D plot group toolbar, click Global.
- 10- In the Settings window for Global, locate the y-Axis Data section.
- 11- In the table, enter the following settings:

Expression	Unit	Description
$V_{cell}$	V	Cell Voltage

- 12- Locate the x-Axis Data section. From the Parameter list, choose Expression.
- 13- In the Expression text field, type bnd1.
- 14- On the 1D plot group toolbar, click Plot.

Next, reproduce a plot showing the power output as a function of the cell voltage (Figure 5.44).

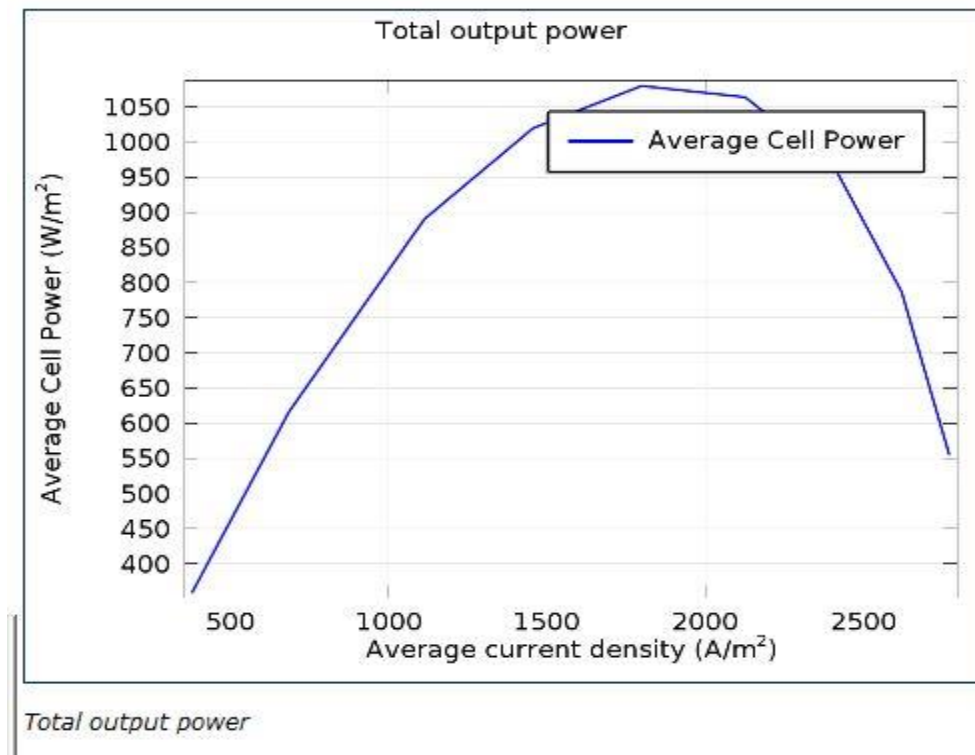

Figure 4.44 shows the power output as a function of the cell voltage. The model predicts a maximum power-output of 940 W/m<sup>2</sup> for the unit cell.

### 1D Plot Group 5

- 1- On the Model toolbar, click Add Plot Group and choose 1D Plot Group.
- 2- In the Settings window for 1D Plot Group, locate the Title section.
- 3- From the Title type list, choose Manual.
- 4- In the Title text area, type Total output power.
- 5- Locate the Plot Settings section. Select the x-axis label check box.
- 6- In the associated text field, type Average current density (A/m<sup>2</sup>).
- 7- Select the y-axis label check box.
- 8- In the associated text field, type Average Cell Power (W/m<sup>2</sup>).
- 9- On the 1D plot group toolbar, click Global.

10- In the Settings window for Global, locate the y-Axis Data section.

11- In the table, enter the following settings:

Expression	Unit	Description
V_cell*bnd1	W/m <sup>2</sup>	Average Cell Power

12- Locate the x-Axis Data section. From the Parameter list, choose Expression.

13- In the Expression text field, type bnd1.

14- On the 1D plot group toolbar, click Plot.

Next reproduce the plot in Figure 45 showing the current density in the unit cell at 0.5V.

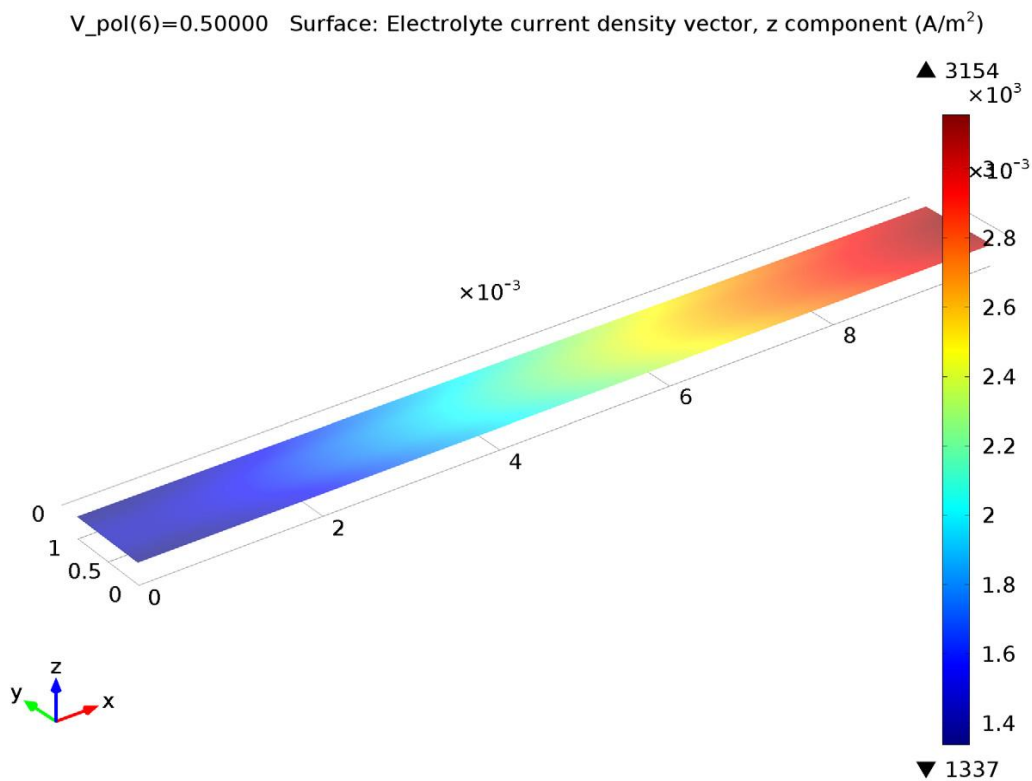

Figure 4.45 The current density in the unit cell operating at 0.5 V. The cathode inlet is to the right.

**Before defining the plot, add the data set for the Boundary 9.**

### **Data Sets**

- 1- On the Results toolbar, click More Data Sets and choose Solution.
- 2- On the Results toolbar, click Selection.
- 3- In the Settings window for Selection, locate the Geometric Entity Selection section.
- 4- From the Geometric entity level list, choose Boundary.
- 5- Select Boundary 9 only.

### **3D Plot Group 6**

- 1- On the Results toolbar, click 3D Plot Group.
- 2- In the Settings window for 3D Plot Group, locate the Data section.
- 3- From the Data set list, choose Study 1/Solution 1 (3).
- 4- From the Parameter value (V\_pol) list, choose 0.50000.
- 5- Locate the Plot Settings section. Clear the Plot data set edges check box.
- 6- Right-click Results>3D Plot Group 6 and choose Surface.
- 7- In the Settings window for Surface, click Replace Expression in the upper-right corner of the Expression section. From the menu, choose Component 1>Secondary Current Distribution>Electrolyte current density vector>siec.IIz - Electrolyte current density vector, z component.

8- On the 3D plot group toolbar, click Plot.

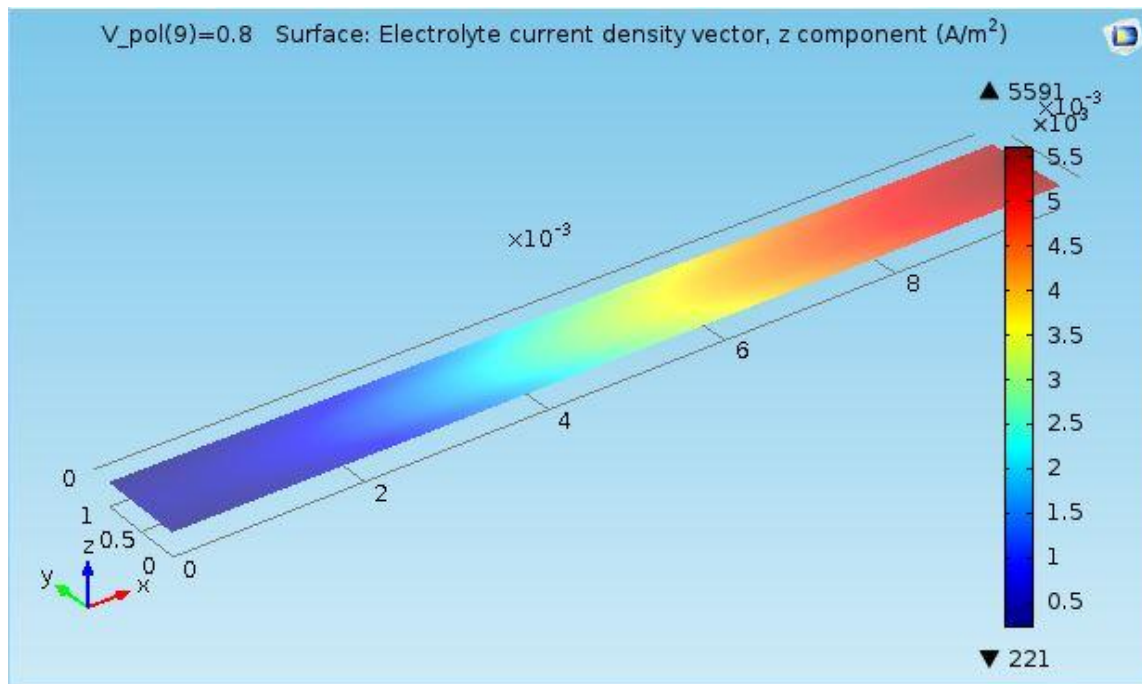

Figure 4.46 The Electrolyte current density in the unit cell operating at 0.5 V.

## **Chapter 5**

### **Simulation of Proton Exchange Membrane Fuel Cell (PEMFC) by using Comsol Multiphysics Program**

---

**5.1 Model**

**5.2 Definitions**

**5.3 Geometry**

**5.4 Physics**

**5.5 Mesh**

**5.6 Study**

**5.7 Results**

## 5.1 Model

NEW

1- In the New window, click Model Wizard.

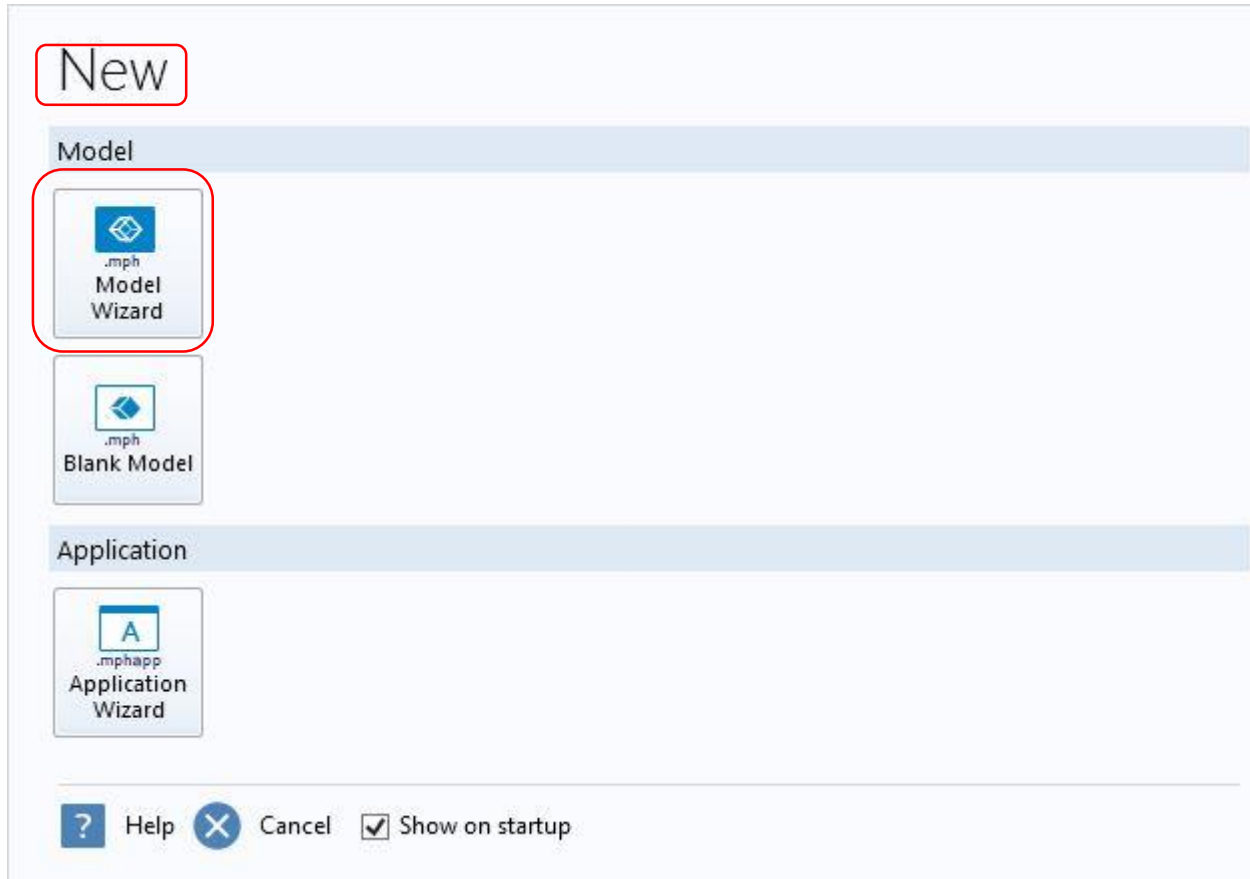

Figure 5.1 New Window

## MODEL WIZARD

1- In the Model Wizard window, click 3D.

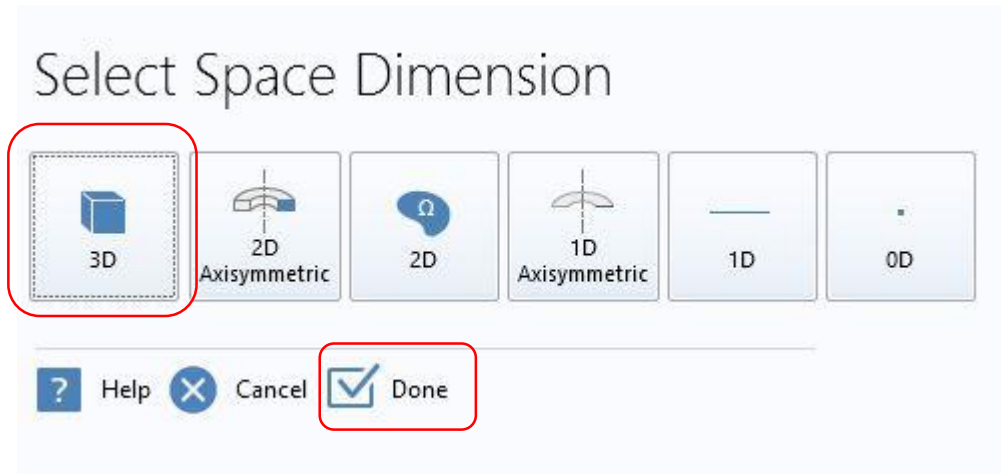

Figure 5.2 Select Space Dimension Window

2- In the Select physics tree, select Electrochemistry>Secondary Current Distribution (siec).

3- Click Add.

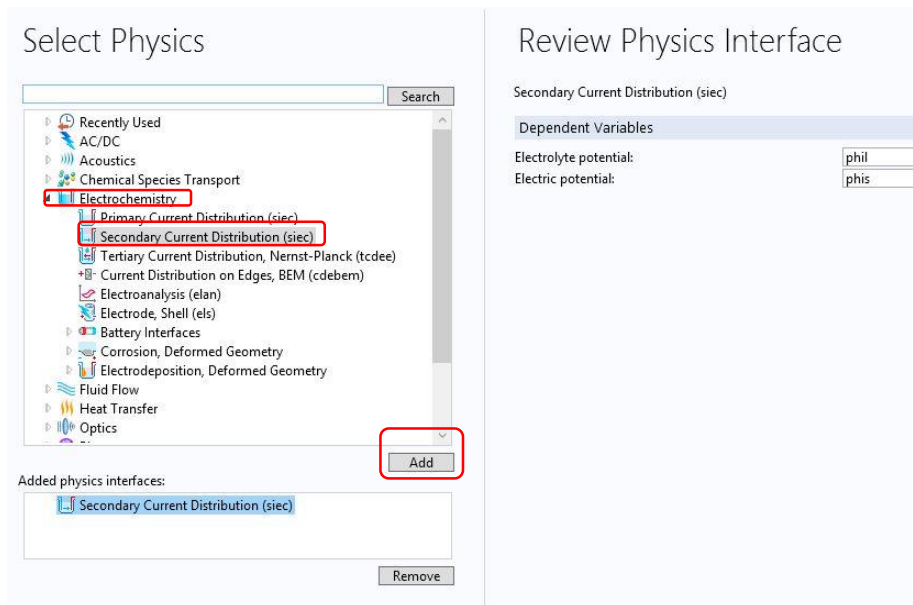

Figure 5.3 Select Physics Window (1)



4- In the Select physics tree, select Chemical Species Transport>Reacting Flow in Porous Media>Transport of Concentrated Species (rfcs).

5- Click Add.

6- In the Mass fractions table, enter the following settings as in figure.

7- In the Velocity field text field, type ua.

8- In the Velocity field components table, enter the following settings as in figure.

9- In the Pressure text field, type pa.

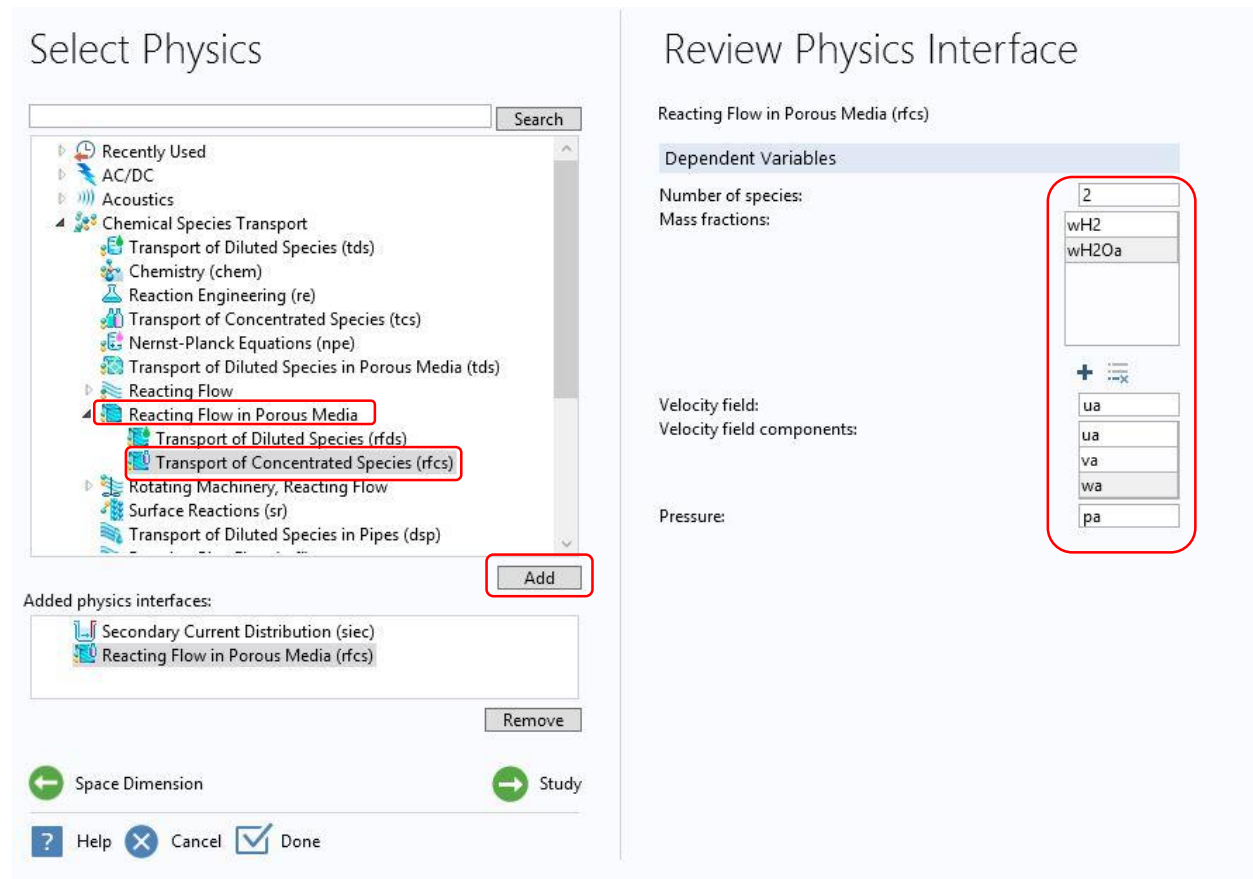

Figure 5.4 Select Physics Window (2)

10- Click Add.

11- In the Number of species text field, type 3.

12- In the Mass fractions table, enter the following settings as in figure.

13- In the Velocity field text field, type uc.

14- In the Velocity field components table, enter the following settings as in figure.

15- In the Pressure text field, type pc.

16- Click Study.

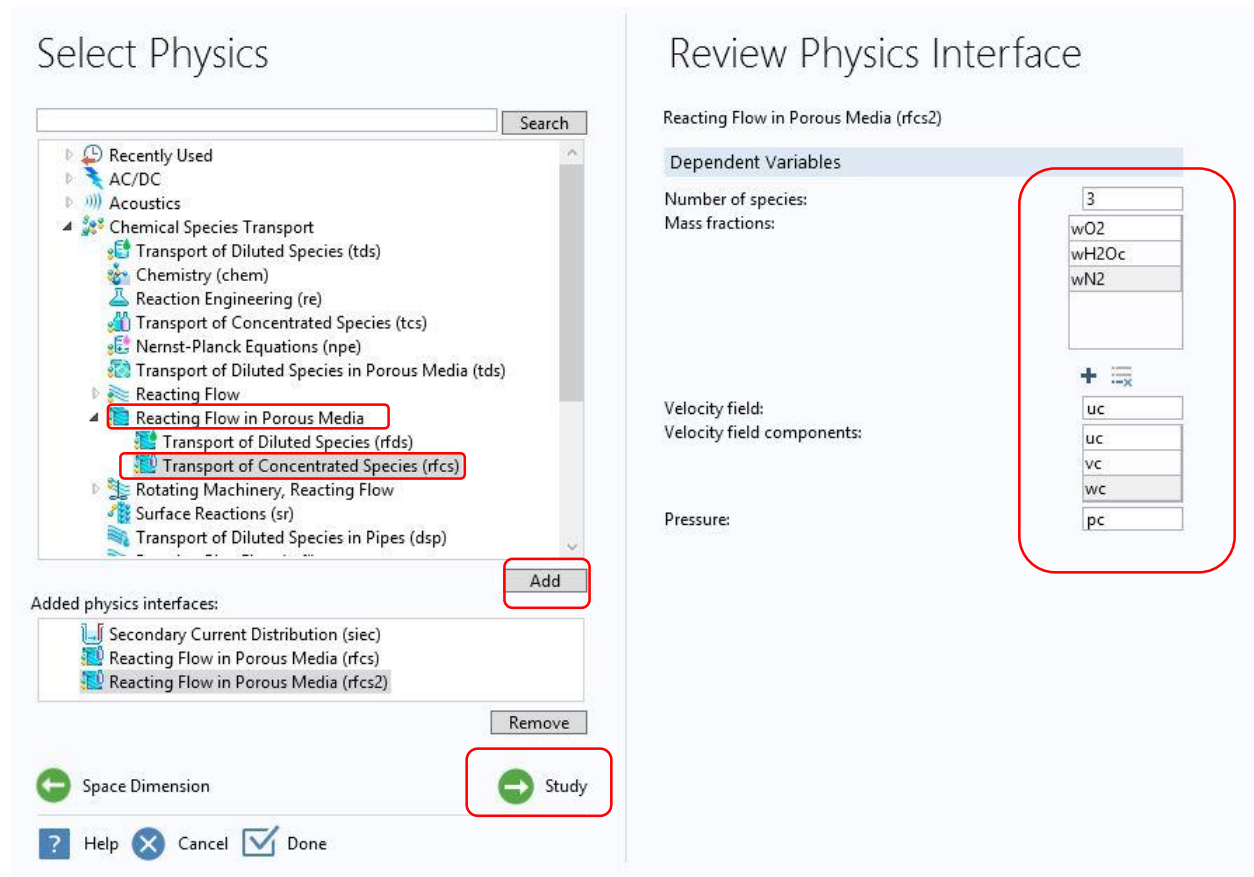

Figure 5.5 Select Physics Window (3)

17- In the Select study tree, select Preset Studies for Selected Physics Interfaces>Stationary.

18-Click Done.

## Select Study

- ▲ Preset Studies for Selected Physics Interfaces
  - AC Impedance Stationary
  - AC Impedance Time Dependent
  - Stationary**
  - Time Dependent
- ▶ Custom Studies

Added study:

Stationary

Added physics interfaces:

- Secondary Current Distribution (siec)
- Reacting Flow in Porous Media (rfcs)
- Reacting Flow in Porous Media (rfcs2)

← Physics

? Help × Cancel **Done**

Figure 5.6 Select Study Window

## 5.2 Definitions

- 1- On the Model toolbar, click Parameters. Load the model parameters from a text file.
- 2- In the Settings window for Parameters, locate the Parameters section.
- 3- Click Load from File, due to parameters collect in text file.
- 4- Browse to the model's Model Library folder and double-click the file pem\_parameters.txt.

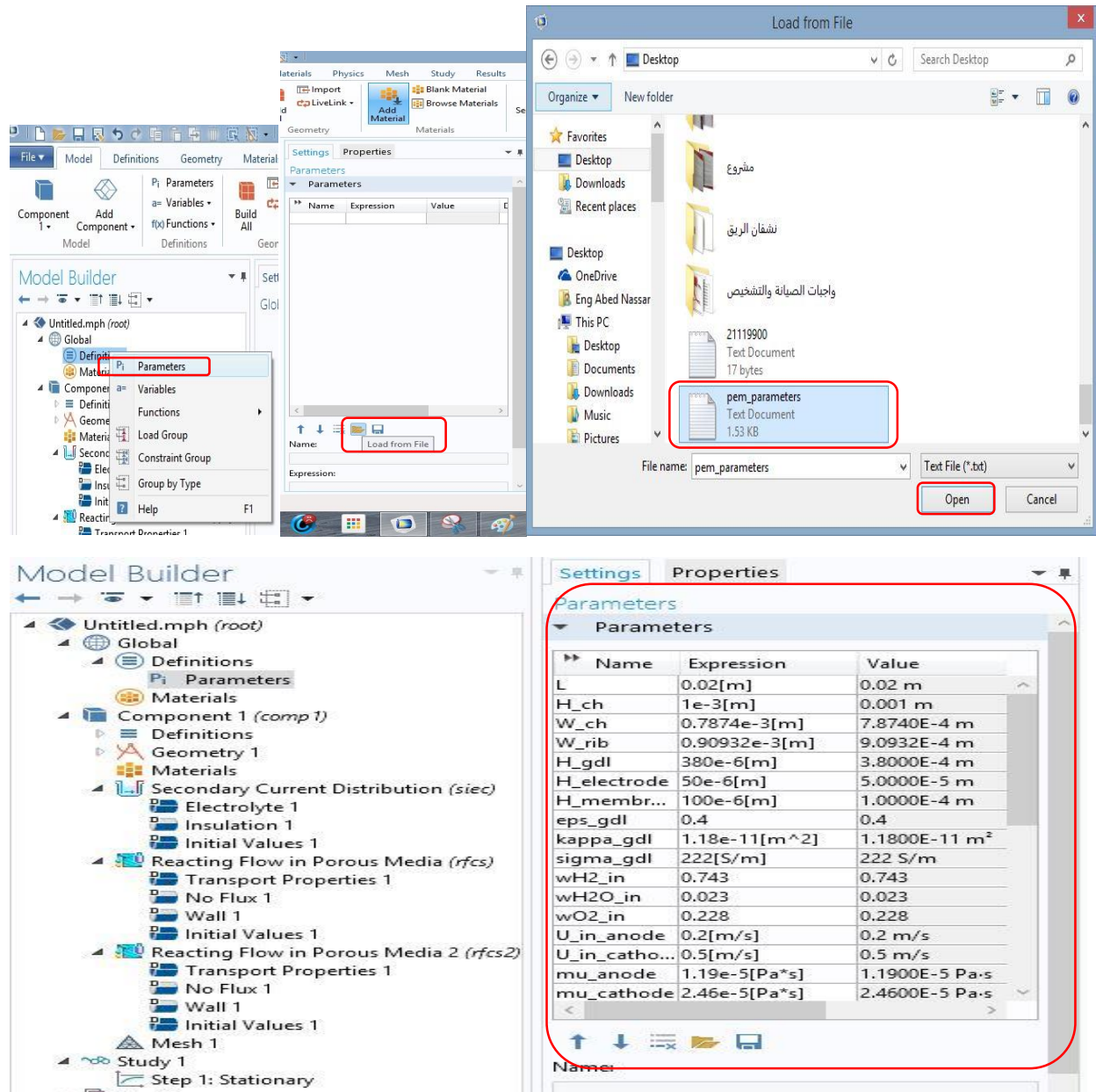

Figure 5.7 Loading Parameters Windows

## 5.3 GEOMETRY

Draw the channels, gas diffusion layers, porous electrodes and the membrane using rectangular blocks.

### Block 1 (blk1)

- 1- On the Geometry toolbar, click Block.
- 2- In the Settings window for Block, locate the Size section.
- 3- In the Width text field, type W\_ch.
- 4- In the Depth text field, type L.
- 5- In the Height text field, type H\_ch.
- 6- Locate the Position section. In the x text field, type W\_rib/2.
- 7- Click the Build Selected button.

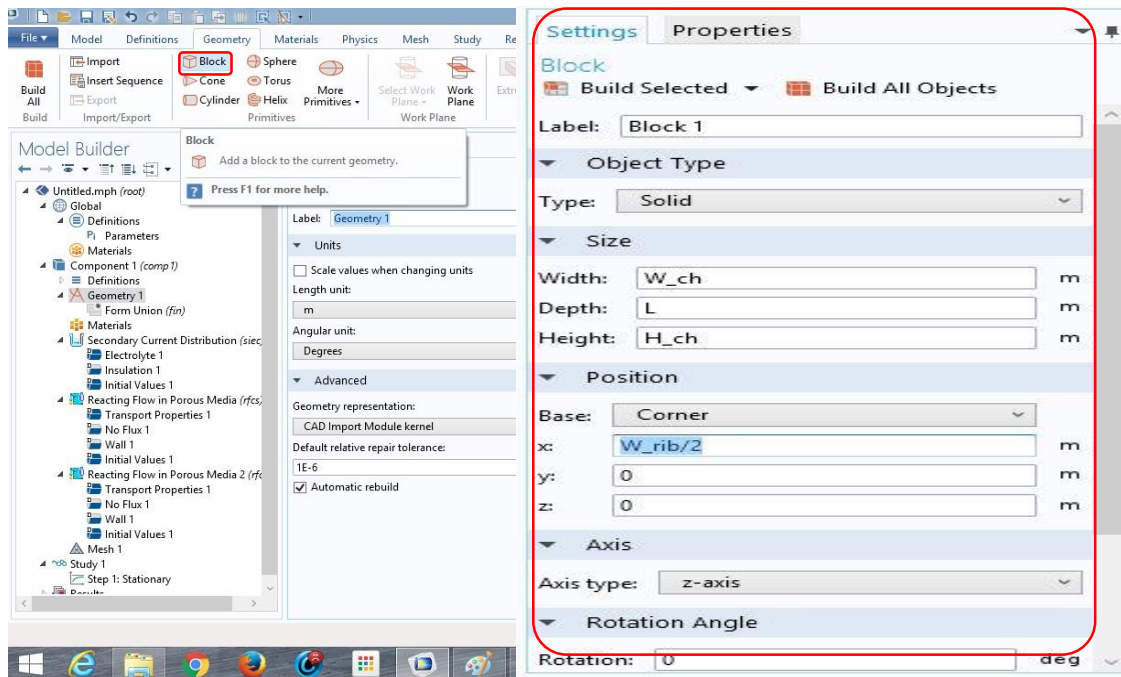

Figure 5.8 Drawing Blocks in Geometry Window

And the same steps for 7 blocks to obtain the shape of the fuel cell in consol without using drawing soft wares and the shape will be in this figure.

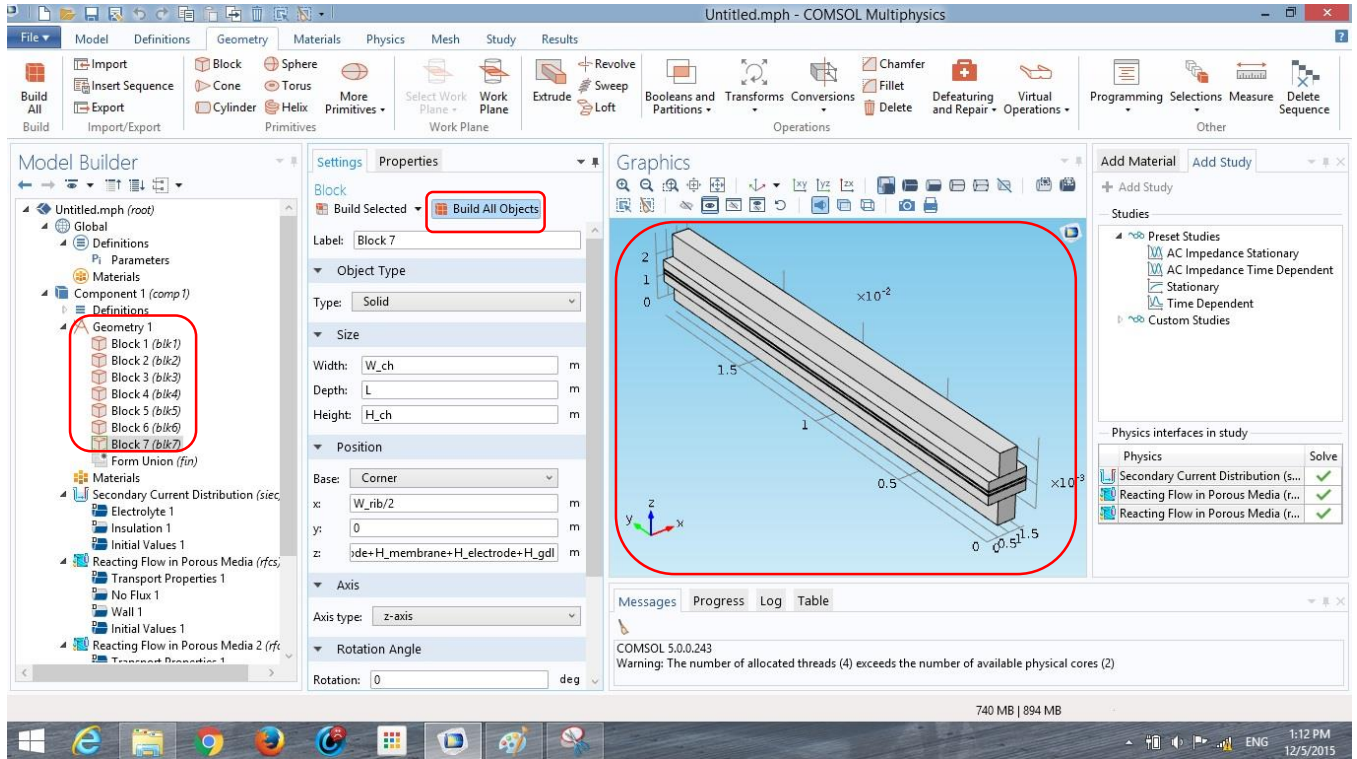

Figure 5.9 Fuel Cell Blocks and shape

Now create selections of certain parts of the geometry to facilitate setting up the physics later on.

### Explicit 1

- 1- On the Definitions toolbar, click Explicit.
- 2- In the Model Builder window, under Component 1 (comp1)>Definitions right-click Explicit 1 and choose Rename.
- 3- In the Rename Explicit dialog box, type Anode Channel in the New label text field.
- 4- Click OK.

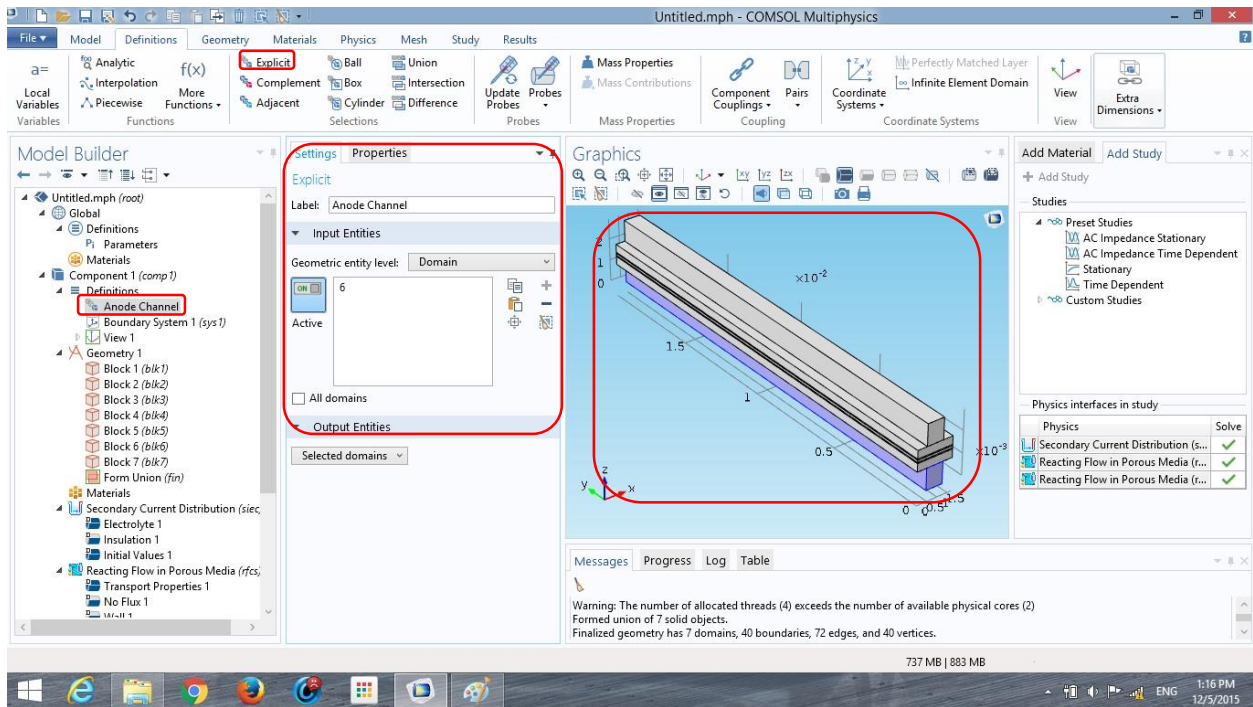

Figure 5.10 Making explicit in Definition Window

And the same steps for 11 explicit and the result will be in this figure.

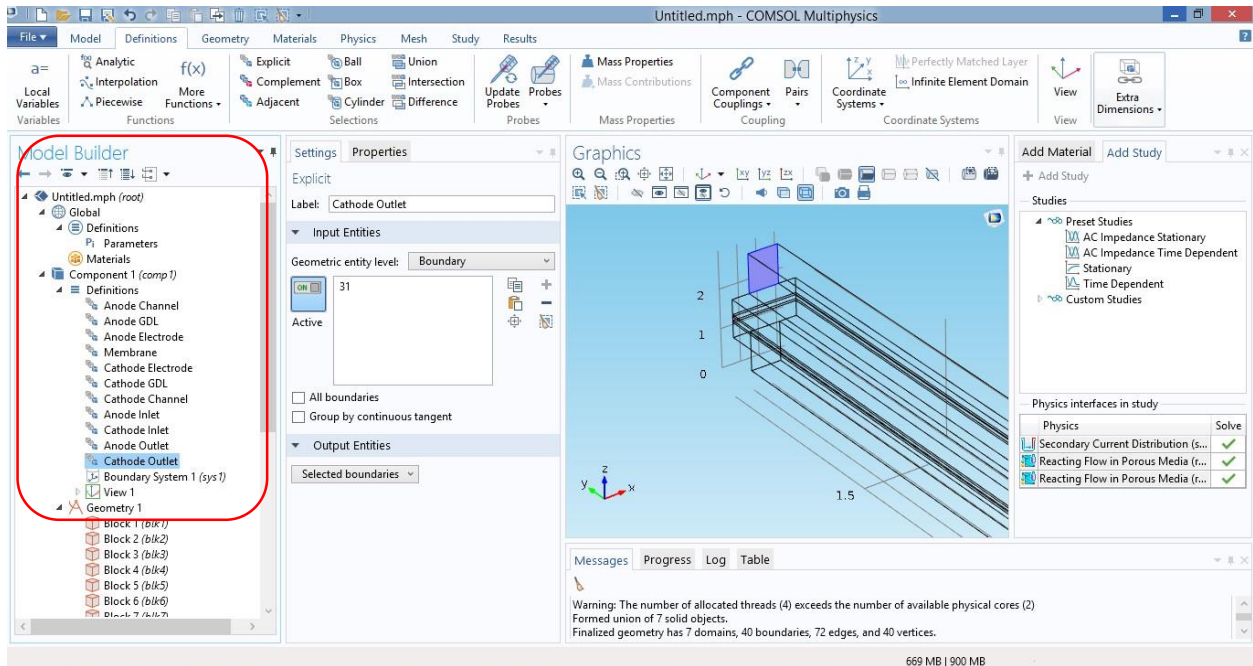

Figure 5.11 Making All explicit in Model Builder Tree

## Union 1

- 1- On the Definitions toolbar, click Union.
- 2- In the Settings window for Union, locate the Input Entities section.
- 3- Under Selections to add, click Add.
- 4- In the Add dialog box, In the Selections to add list, choose Anode Channel, Anode GDL, and Anode Electrode.
- 5- Click OK.
- 6- Right-click Component 1 (comp1)>Definitions>Union 1 and choose Rename.
- 7- In the Rename Union dialog box, type Anode Compartment in the New label text field.
- 8- Click OK.

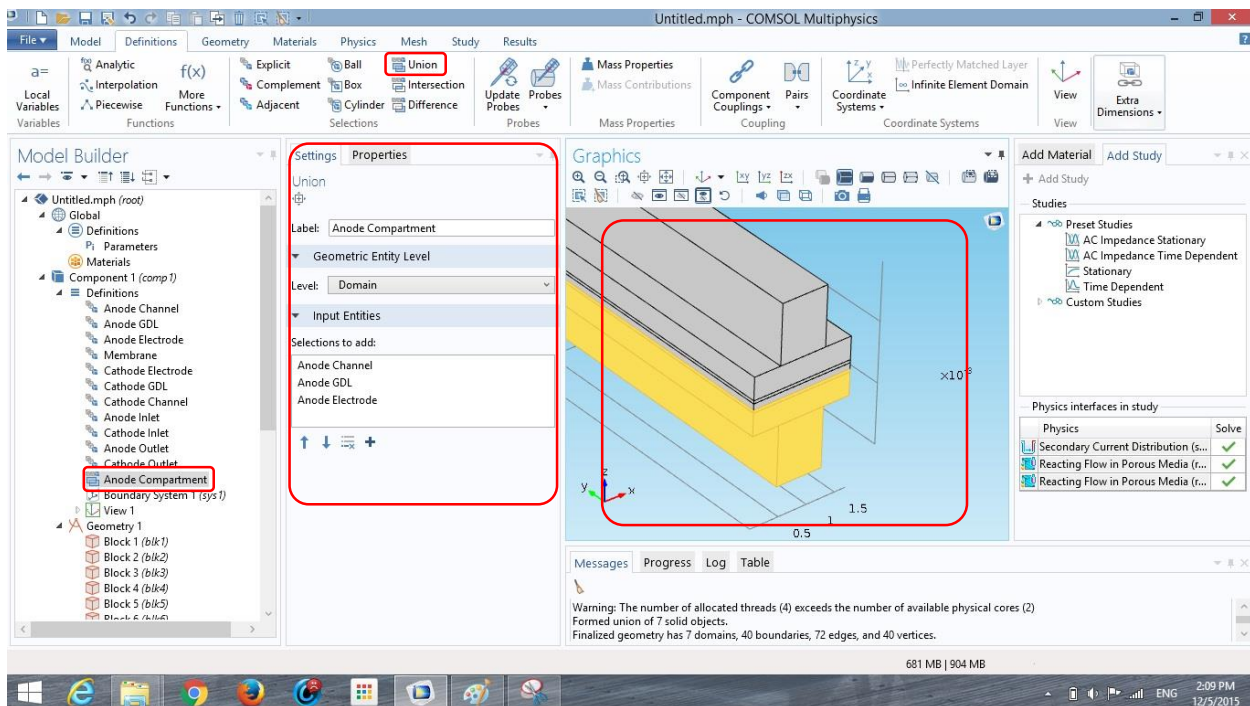

Figure 5.12 Making Union (1) in Definition Window



## Union 2

- 1- On the Definitions toolbar, click Union.
- 2- In the Settings window for Union, locate the Input Entities section.
- 3- Under Selections to add, click Add.
- 4- In the Add dialog box, In the Selections to add list, choose Cathode Electrode, Cathode GDL, and Cathode Channel.
- 5- Click OK.
- 6- Right-click Component 1 (comp1)>Definitions>Union 2 and choose Rename.
- 7- In the Rename Union dialog box, type Cathode Compartment in the New label text field.
- 8- Click OK.

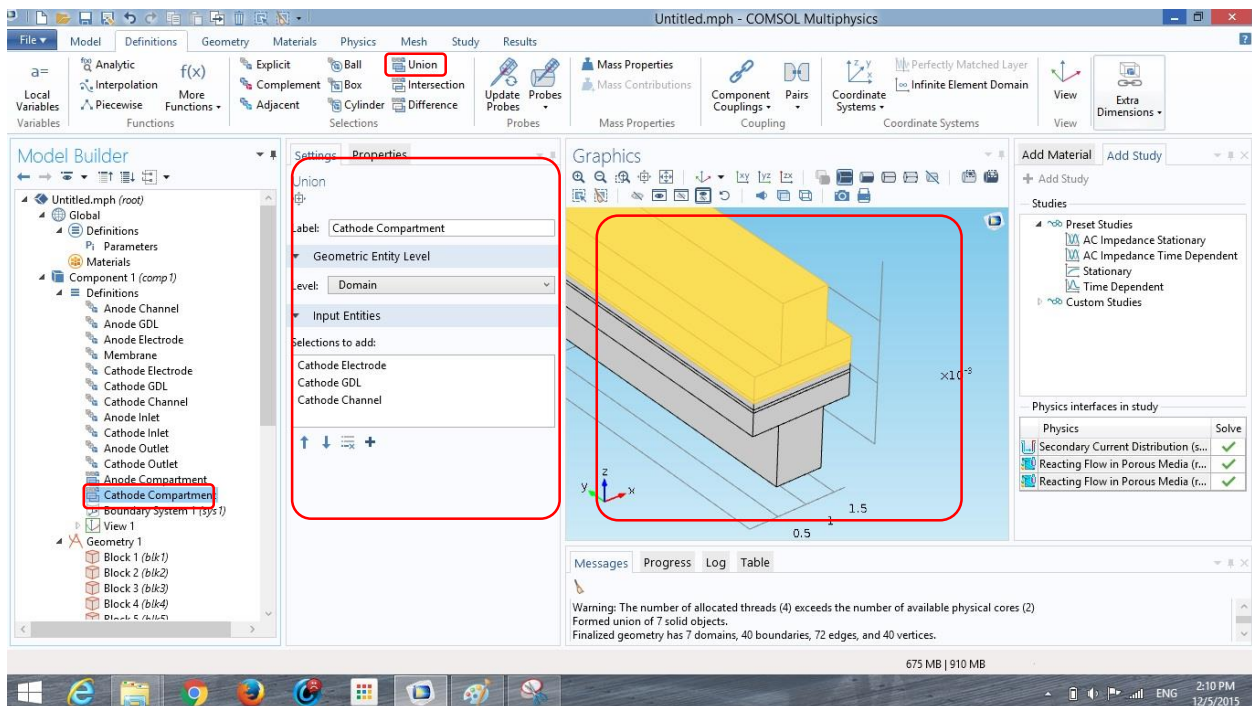

Figure 5.13 Making Union (2) in Definition Window

## 5.4 Physics

### SECONDARY CURRENT DISTRIBUTION (SIEC)

Set up the model for the current distribution. There are no currents flowing in the gas channels.

- 1- Select Domains 1–5 only.

#### Porous Electrode 1

- 1- On the Physics toolbar, click Domains and choose Porous Electrode.
- 2- In the Settings window for Porous Electrode, locate the Domain Selection section.
- 3- From the Selection list, choose Anode Electrode.
- 4- Locate the Electrolyte Current Conduction section. From the  $\sigma_l$  list, choose User defined. In the associated text field, type sigma\_m.
- 5- In the  $\epsilon_l$  text field, type eps\_1.
- 6- Locate the Electrode Current Conduction section. From the  $\sigma_s$  list, choose User defined. In the associated text field, type sigma\_gdl.
- 7- From the Effective conductivity correction list, choose No correction.

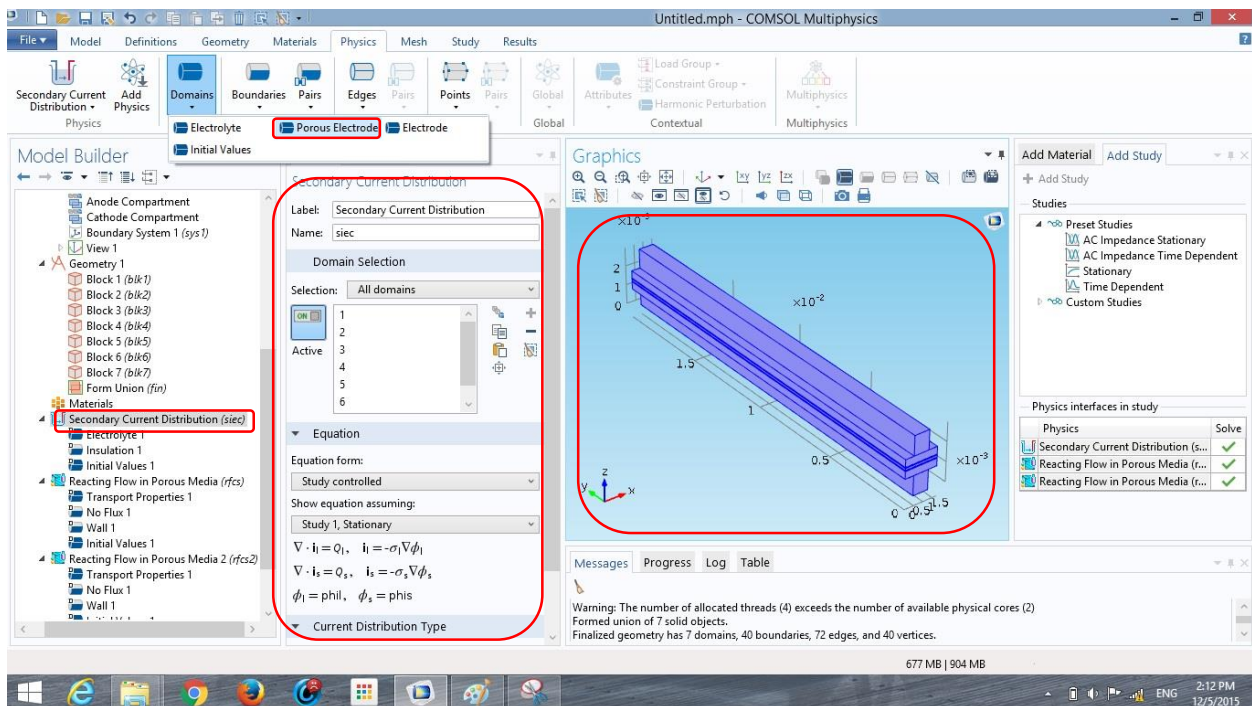

Figure 5.14 Making Porous Electrode in Physics Window

## Porous Electrode Reaction 1

- 1- In the Model Builder window, expand the Porous Electrode 1 node, then click Porous Electrode Reaction 1.
- 2- In the Settings window for Porous Electrode Reaction, locate the Model Inputs section.
- 3- In the  $T$  text field, type T.
- 4- Locate the Electrode Kinetics section. In the  $i_0$  text field, type  $1e5[A/m^2]*(r_{fcs.c\_wH2}/c_{H2\_ref})^{0.5}$ .
- 5 In the  $a_c$  text field, type 1.
- 6- In the  $a_v$  text field, type 1.
- 7- Locate the Active Specific Surface Area section. In the  $a_v$  text field, type  $1e4$ .

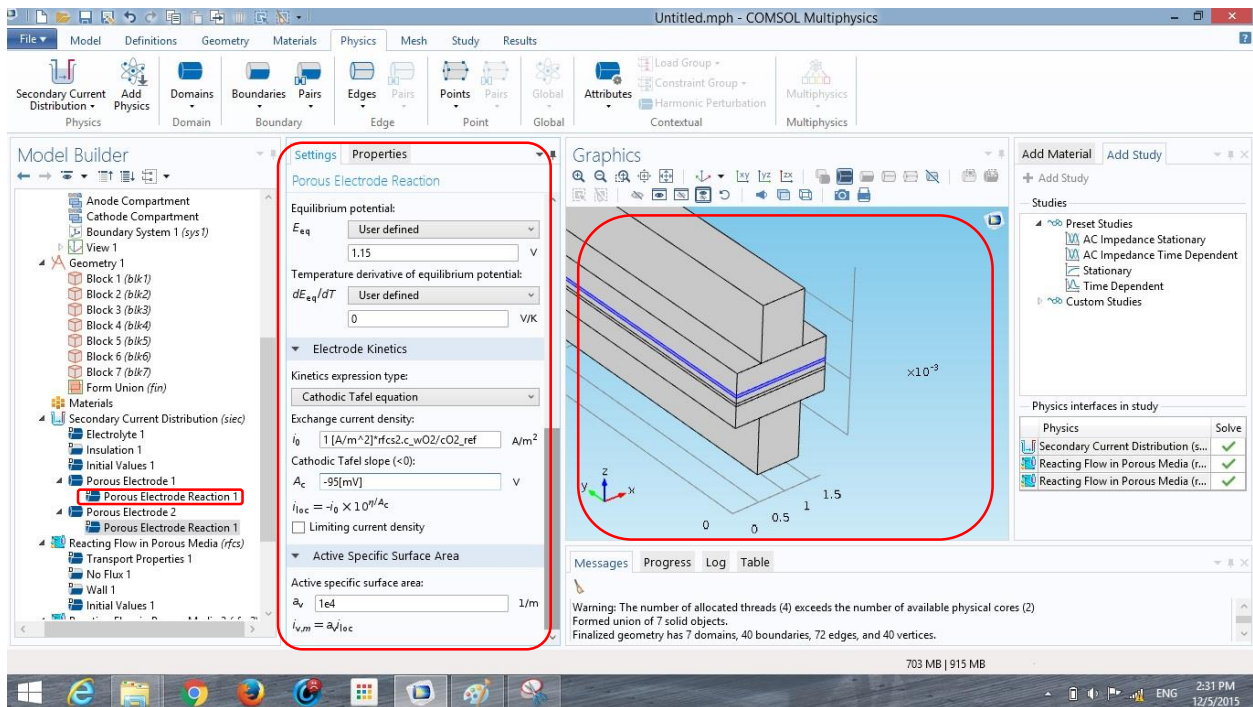

Figure 5.15 Making Porous Electrode Reaction

And same steps for obtaining Porous Electrode 2 and Porous Electrode Reaction 1 for electrode 2 with some changes of the variables for cathode.

## Electrode 1

In the gas diffusion layers there are no electrochemical reactions occurring, and there is no electrolyte present. The current conduction in these domains are modeled using Electrode nodes.

- 1- On the Physics toolbar, click Domains and choose Electrode.
- 2- Select Domains 1 and 5 only.
- 3- In the Settings window for Electrode, locate the Electrode section.
- 4- From the  $\sigma_s$  list, choose User defined. In the associated text field, type sigma\_gdl.

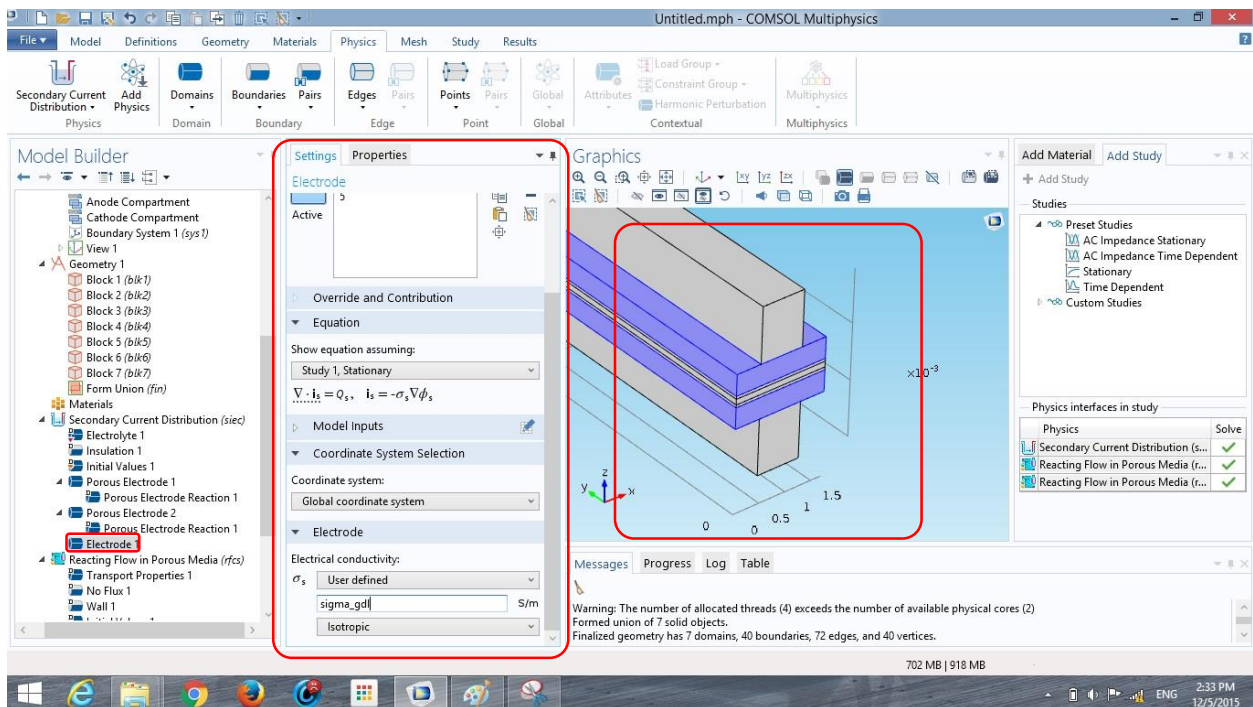

Figure 5.16 Making Electrode

## Electrolyte 1

- 1- In the Model Builder window, under Component 1 (comp1)>Secondary Current Distribution (siec) click Electrolyte 1.
- 2- In the Settings window for Electrolyte, locate the Electrolyte section.
- 3- From the  $\sigma_l$  list, choose User defined. In the associated text field, type sigma\_m.

## Electric Ground 1

The domain settings describing the physics of the electrochemical reactions and currents are now complete. Now ground the anode side of the cell and set the cathode side to the cell potential.

- 1- On the Physics toolbar, click Boundaries and choose Electric Ground.
- 2- Select Boundaries 3 and 33 only.

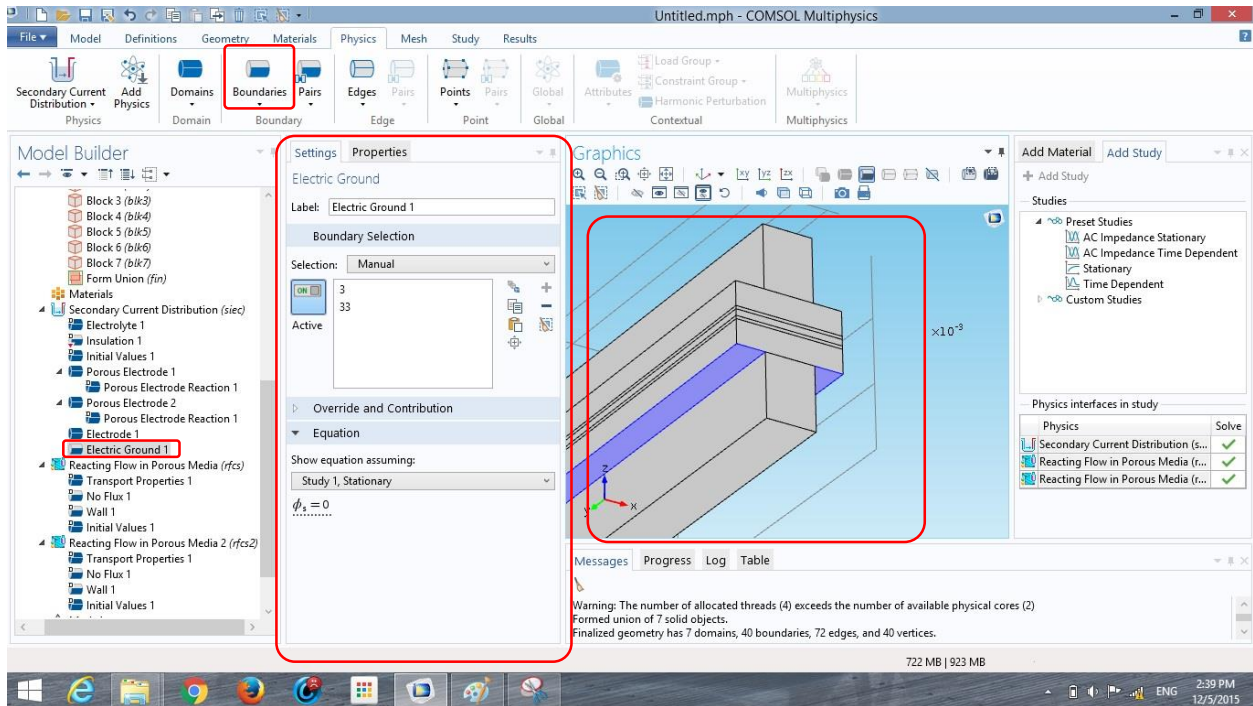

Figure 5.17 Making Electric Ground

## Electric Potential 1

- 1- On the Physics toolbar, click Boundaries and choose Electric Potential.
- 2- Select Boundaries 16 and 35 only.
- 3- In the Settings window for Electric Potential, locate the Electric Potential section.
- 4- In the  $\phi_s, \text{bnd}$  text field, type  $V_{\text{cell}}$ .

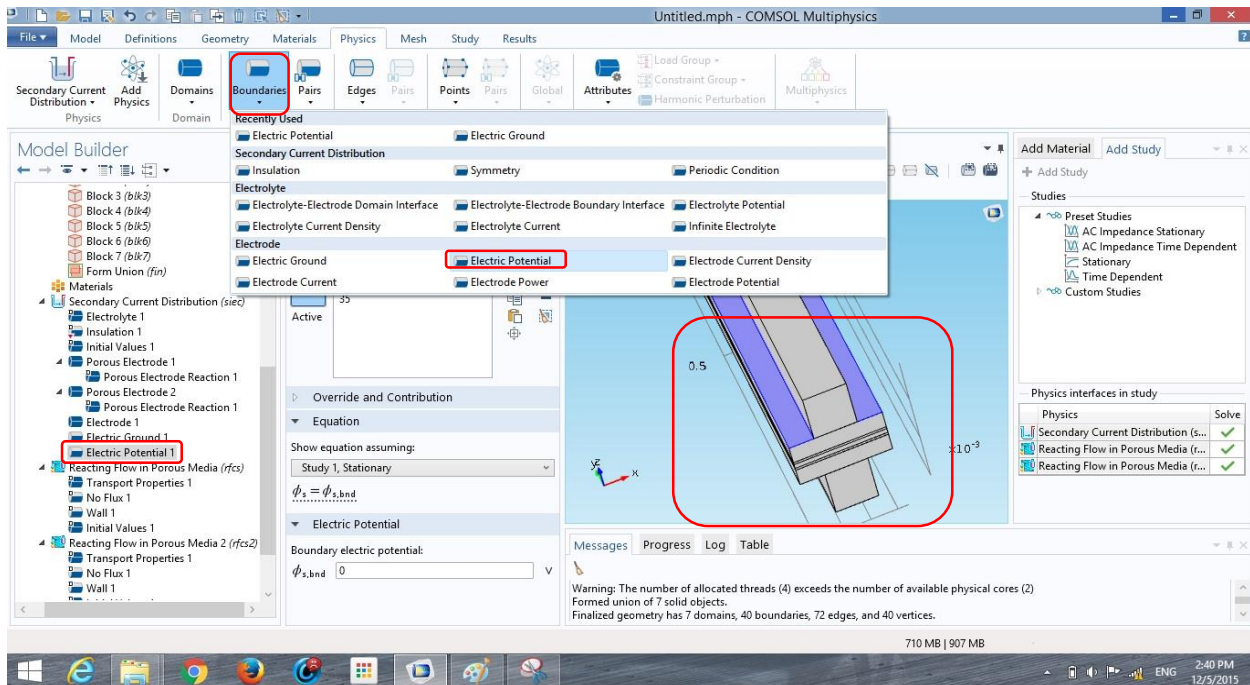

Figure 5.18 Making Electric Potential

## Initial Values 2

- 1- On the Physics toolbar, click Domains and choose Initial Values.
- 2- Select Domains 4 and 5 only.
- 3- In the Settings window for Initial Values, locate the Initial Values section.
- 4- In the phis text field, type  $V_{cell}$ .

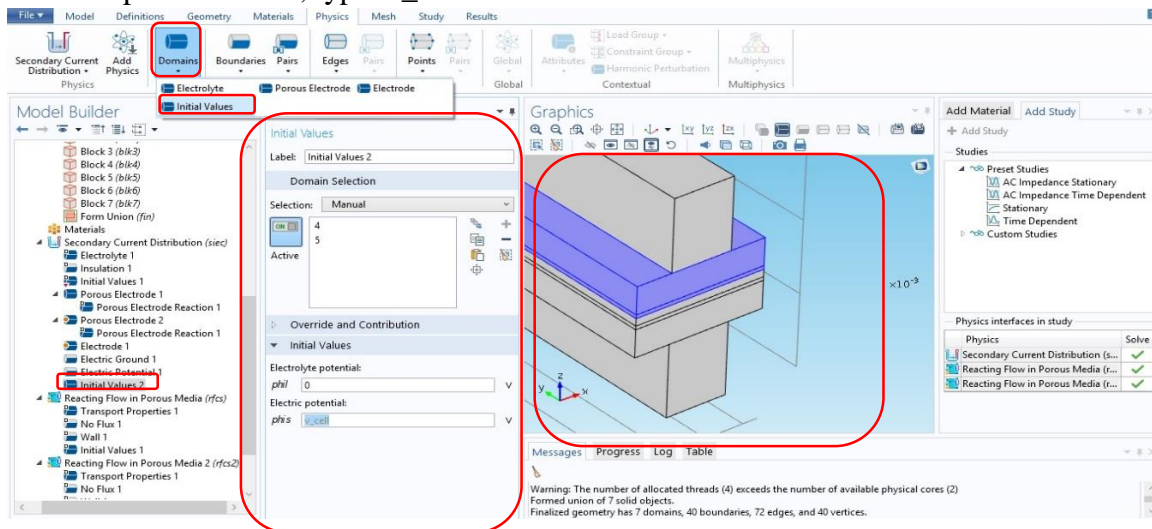

Figure 5.19 Putting Initial values

## REACTING FLOW IN POROUS MEDIA (RFCS)

Now set up the mass transfer in the anode gas compartment.

1- In the Model Builder window, under Component 1 (comp1) click Reacting Flow in

**Porous Media (rfcs).**

2- In the Settings window for Reacting Flow in Porous Media, locate the DomainSelection Section.

3- From the Selection list, choose Anode Compartment.

4- Locate the Species section. From the mass constraint list, choose wH2Oa.

5- Locate the Physical Model section. From the Diffusion model list, choose Maxwell-Stefan.

Define the pressure reference level in the interface properties.

6- In the pref text field, type p\_ref.

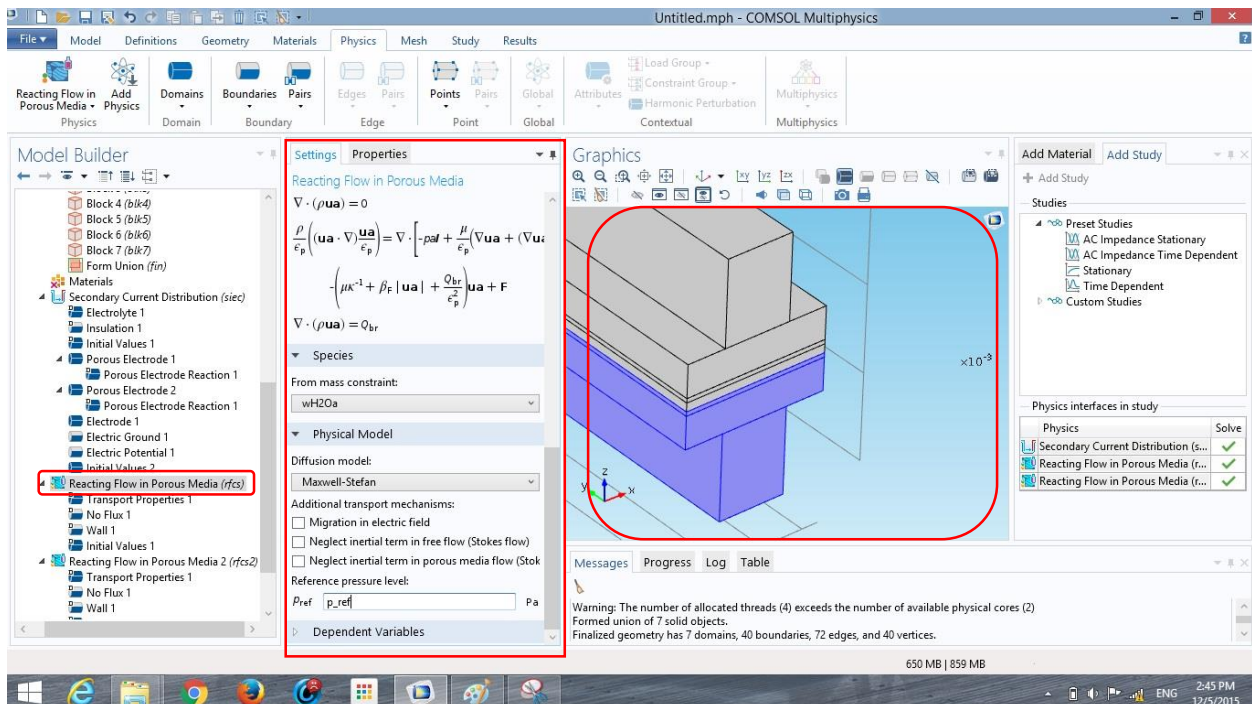

Figure 5.20 Making Reacting Flow in Porous Media

## Porous Matrix Properties 1

- 1- On the Physics toolbar, click Domains and choose Porous Matrix Properties.
  - 2- In the Settings window for Porous Matrix Properties, locate the Domain Selection section.
  - 3- From the Selection list, choose Anode GDL.
  - 4- Locate the Porous Matrix Properties section. From the  $\epsilon_p$  list, choose User defined. In the associated text field, type eps\_gdl.
  - 5- From the  $\kappa$  list, choose User defined. In the associated text field, type kappa\_gdl.
- Use a Bruggeman correction to take into account the impact of the porous matrix on gas phase mass transport.
- 6- From the Effective mass transport parameters list, choose Bruggeman.

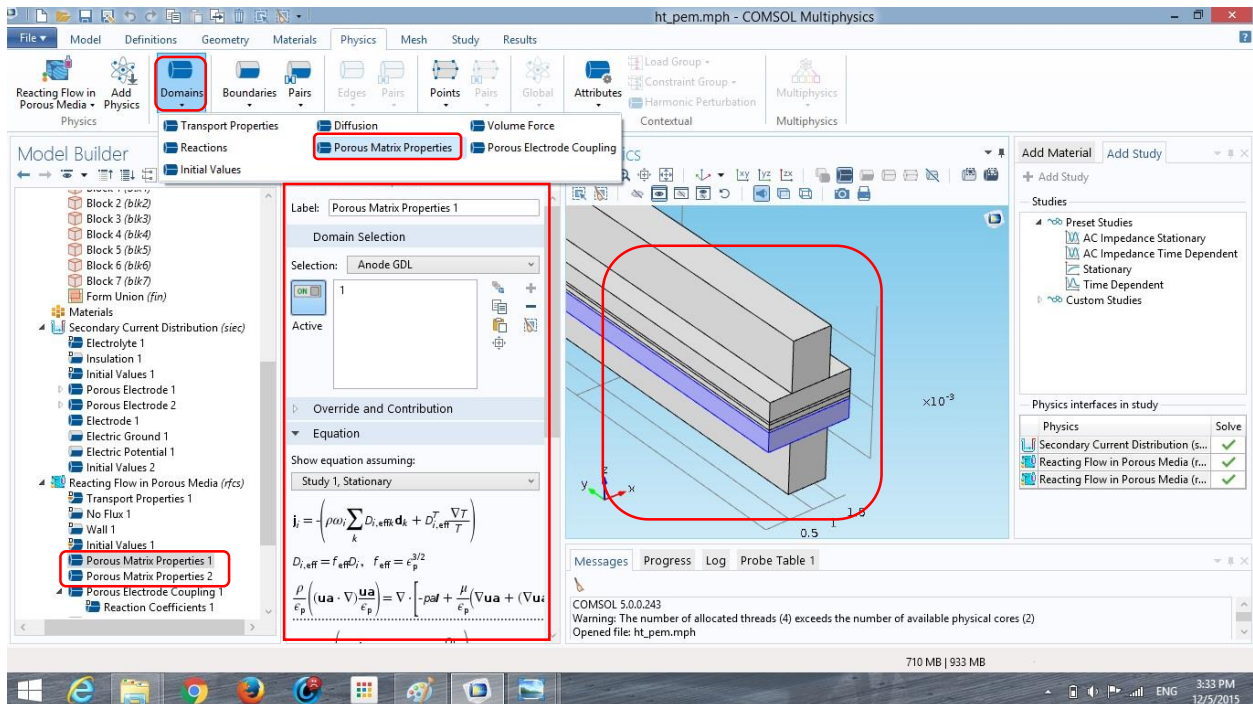

Figure 5.21 Making Porous Matrix Properties



### **Inflow 1**

Now set up the inlet and outlet conditions on the corresponding boundaries.

- 1- On the Physics toolbar, click Boundaries and choose Inflow.
- 2- In the Settings window for Inflow, locate the Boundary Selection section.
- 3- From the Selection list, choose Anode Inlet.
- 4- Locate the Inflow section. In the  $w_0, w_{H2}$  text field, type  $w_{H2\_in}$ .

### **Outflow 1**

- 1- On the Physics toolbar, click Boundaries and choose Outflow.
- 2- In the Settings window for Outflow, locate the Boundary Selection section.
- 3- From the Selection list, choose Anode Outlet.

### **Inlet 1**

- 1- On the Physics toolbar, click Boundaries and choose Inlet.
- 2- In the Settings window for Inlet, locate the Boundary Selection section.
- 3- From the Selection list, choose Anode Inlet.
- 4- Locate the Boundary Condition section. From the list, choose Laminar inflow.
- 5- Locate the Laminar Inflow section. In the  $U_{av}$  text field, type  $U_{in\_anode}$ .
- 6- In the  $L_{entr}$  text field, type  $1e-2$ .
- 7- Select the Constrain outer edges to zero check box.

### **Outlet 2**

- 1- On the Physics toolbar, click Boundaries and choose Outlet.
- 2- In the Settings window for Outlet, locate the Boundary Selection section.
- 3- From the Selection list, choose Anode Outlet.
- 4- Locate the Pressure Conditions section. Select the Normal flow check box.

## Symmetry 1

- 1- On the Physics toolbar, click Boundaries and choose Symmetry.
- 2- In the Settings window for Symmetry, locate the Boundary Selection section.
- 3- Click Paste Selection.
- 4- In the Paste Selection dialog box, type 1, 4, 36-37 in the Selection text field.
- 5- Click OK.

## Initial Values 1

- 1- In the Model Builder window, under Component 1 (comp1)>Reacting Flow in Porous Media (rfcs) click Initial Values 1.
- 2- In the Settings window for Initial Values, locate the Initial Values section.
- 3- In the w0,wh2 text field, type wh2\_in.

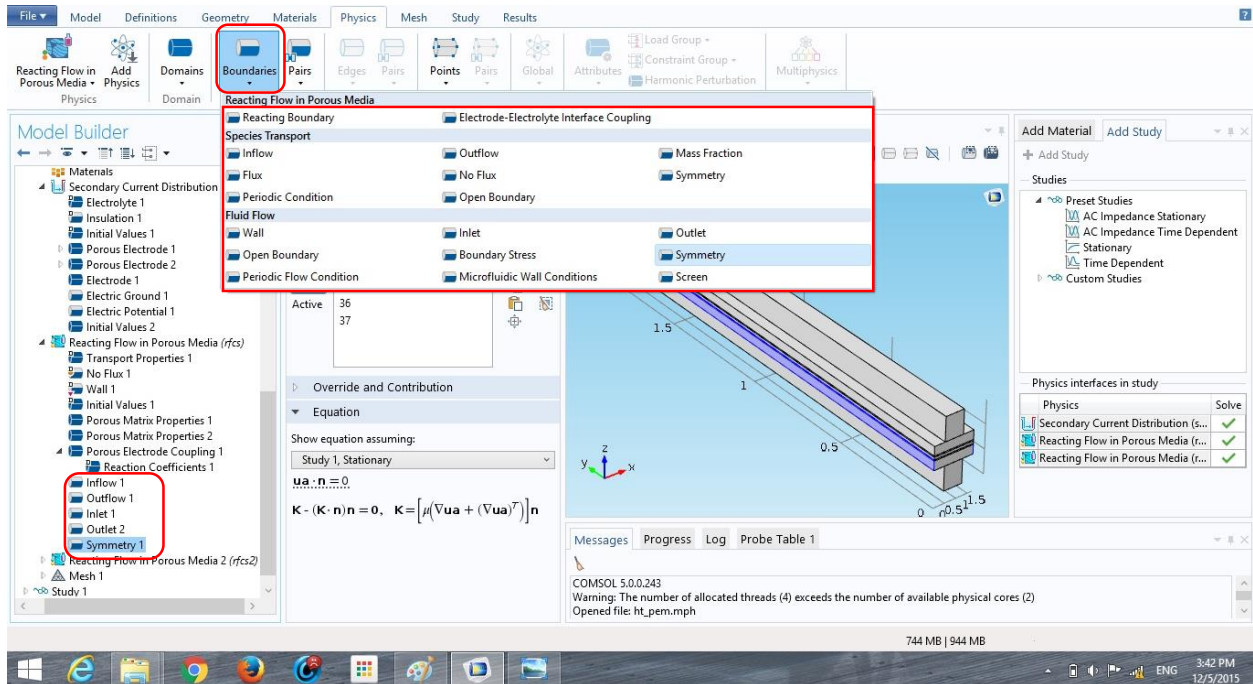

Figure 5.22 Making Inflow & Outflow & Inlet & Outlet & Symmetry Reacting Flow in Porous Media (1)

And the same steps for Reacting Flow in Porous Media 2 (RFCS2) but for cathode type with some of changes in parameters and the steps in picture.

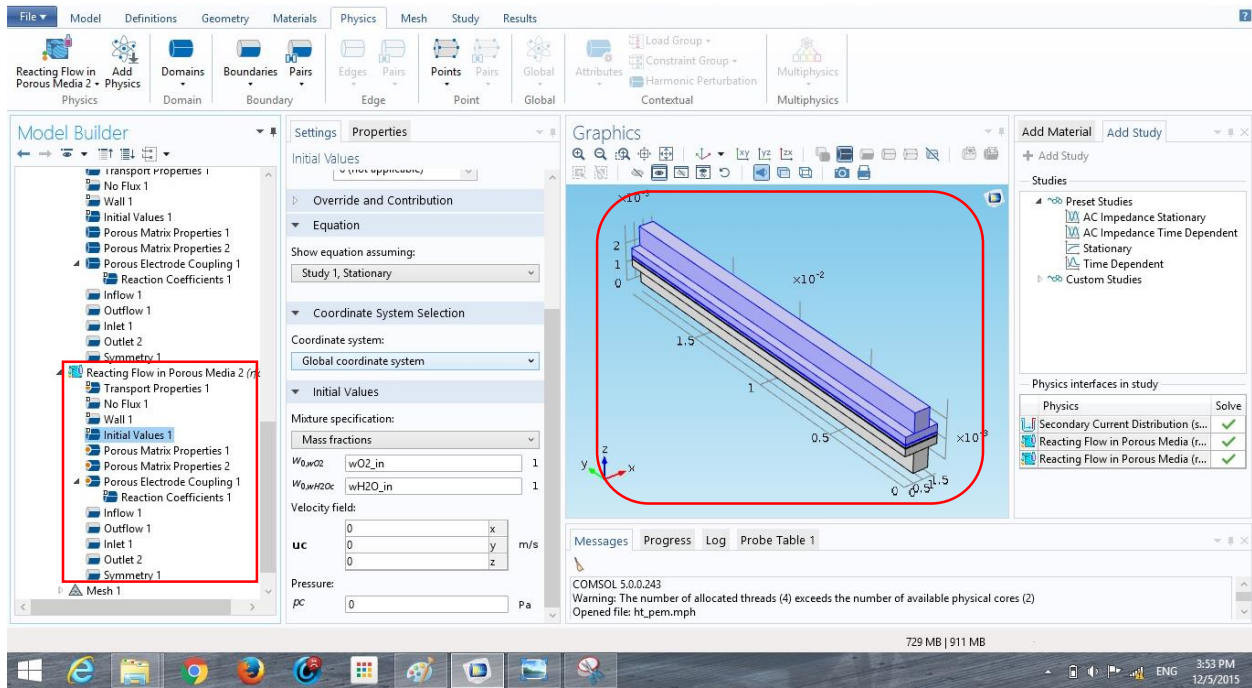

Figure 5.23 Making Inflow & Outflow & Inlet & Outlet & Symmetry Reacting Flow in Porous Media (2)

## 5.5 Mesh

### MESH 1

First create a mapped 2D mesh in the plane normal to the channel direction, then sweep this mesh in the channel direction.

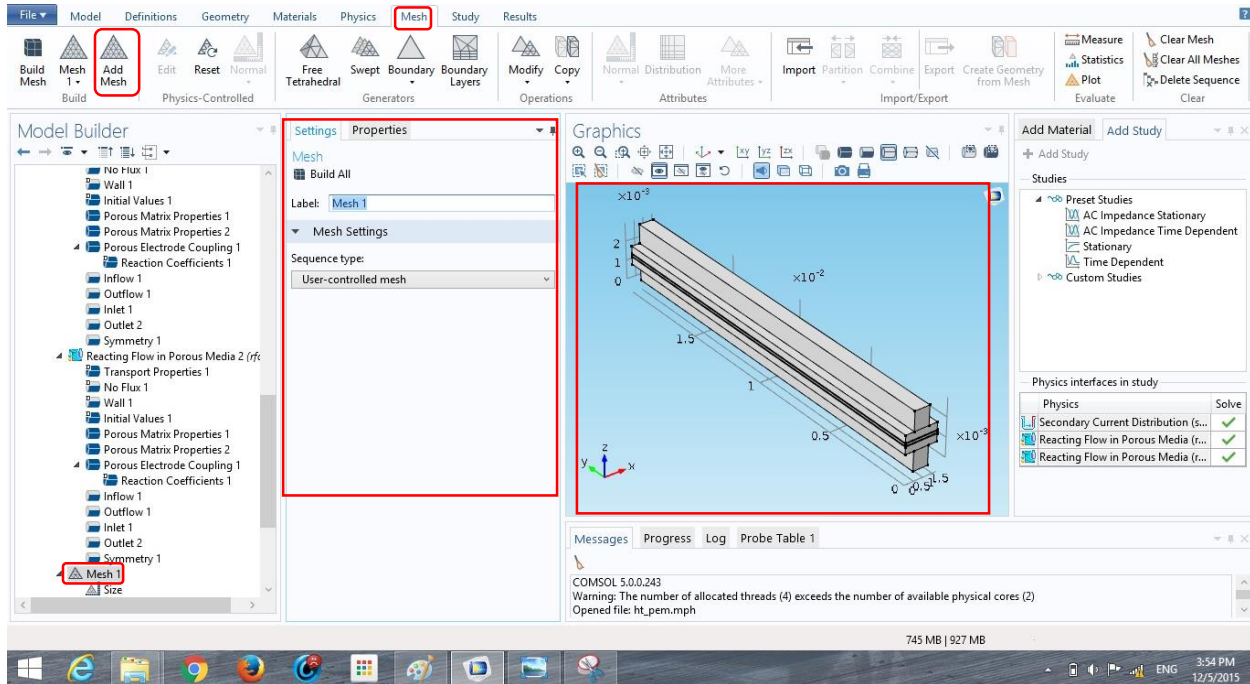

Figure 5.24 Adding Mesh in Mesh Window

### Edge 1

- 1- In the Model Builder window, under Component 1 (comp1) right-click Mesh 1 and choose More Operations>Edge.
- 2- Select Edges 3, 17, 33, 36, 48, and 51 only.

### Size 1

- 1- Right-click Component 1 (comp1)>Mesh 1>Edge 1 and choose Size.
- 2- In the Settings window for Size, locate the Element Size section.

3- Click the Custom button.

4- Locate the Element Size Parameters section. Select the Maximum element size check box.

5- In the associated text field, type  $W_{ch}/8$ .

## Edge 2

1- In the Model Builder window, right-click Mesh 1 and choose More Operations>Edge.

2- Select Edges 13 and 65 only.

## Distribution 1

1- Right-click Component 1 (comp1)>Mesh 1>Edge 2 and choose Distribution.

2- In the Settings window for Distribution, locate the Distribution section.

3- From the Distribution properties list, choose Predefined distribution type.

4- In the Number of elements text field, type 8.

5- In the Element ratio text field, type 4.

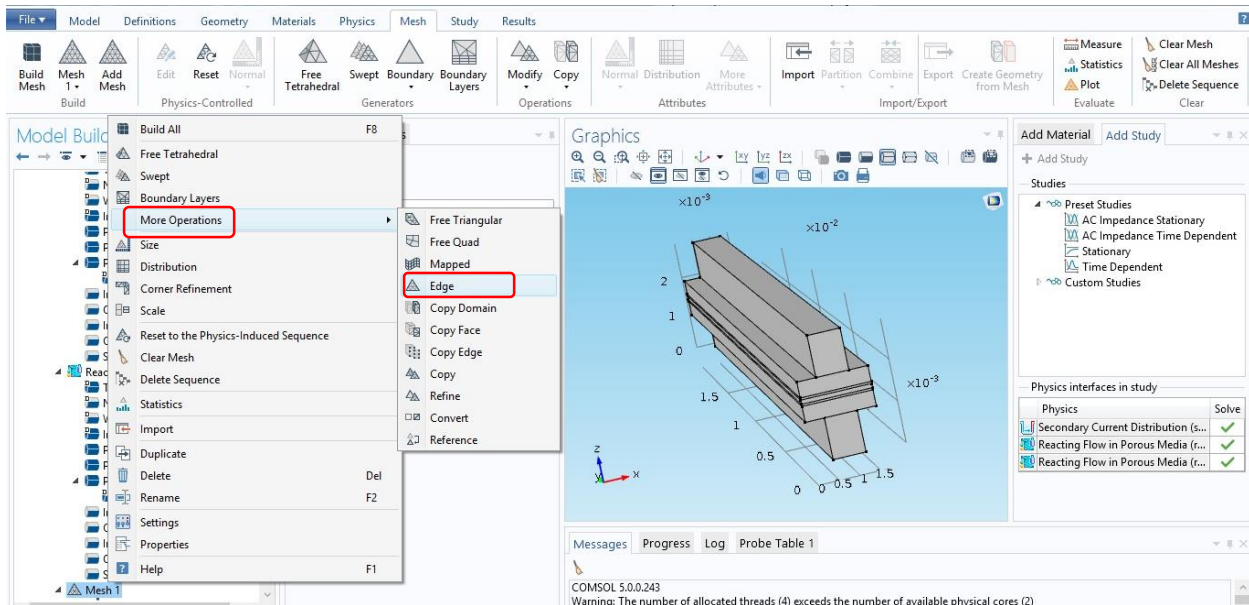

Figure 5.25 Adding Edge & Distribution in Mesh

And the same steps for 7 edges and distribution for all edges after this we will make:

### **A-Mapped 1**

1- In the Model Builder window, right-click Mesh 1 and choose More Operations>Mapped.

2- Select Boundaries 2, 5, 8, 11, 14, 23, and 27 only.

### **B-Swept 1**

Right-click Mesh 1 and choose Swept.

### **C-Size 1**

1 In the Model Builder window, under Component 1 (comp1)>Mesh 1 right-click Swept 1 and choose Size.

2 In the Settings window for Size, locate the Element Size section.

3 Click the Custom button.

4 Locate the Element Size Parameters section. Select the Maximum element size check box.

5 In the associated text field, type W\_ch.

6 Click the Build Selected button.

Shown in the figure 5.26.

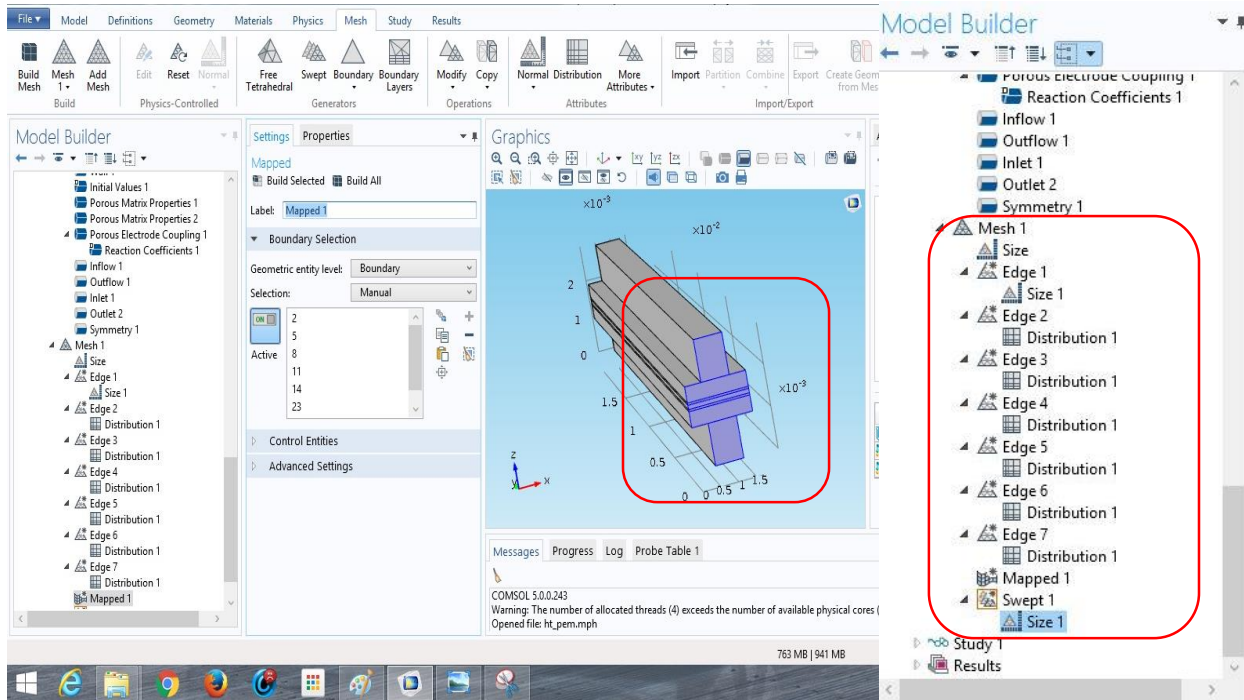
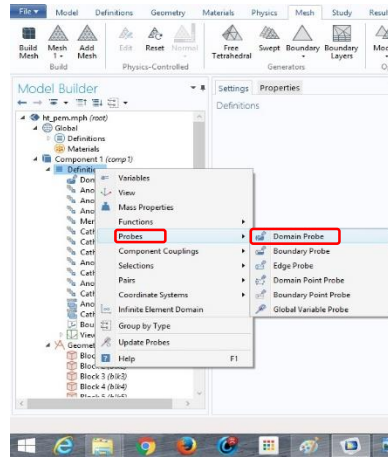

Figure 5.26 Edge & Distribution & Mapped & Swept in Mesh

## DEFINITIONS

Add a domain probe for the integral of the electrochemical current density to get a Polarization plot automatically during the parametric solver process. You can then use this probe also for creating a polarization curve during postprocessing.

- 1- On the Definitions toolbar, click Probes and choose Domain Probe.
- 2- In the Settings window for Domain Probe, locate the Probe Type section.
- 3- From the Type list, choose Integral.



- 4- Locate the Source Selection section. From the Selection list, choose Anode Electrode.
- 5- Locate the Expression section. In the Expression text field, type  $\text{siec.iv\_per1}/((W\_ch+W\_rib)*L)/1e4$ .

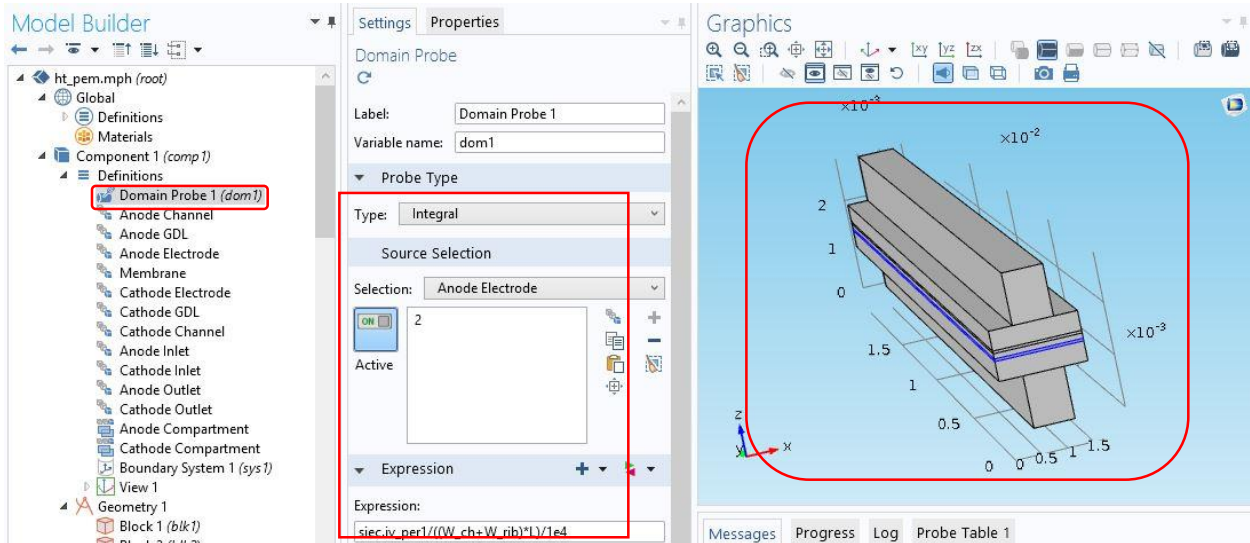

Figure 5.27 Making Domain Probe Definition in Model Builder Tree



## 5.6 Study

### STUDY 1

The problem is now ready for solving. Use an auxiliary sweep with continuation to solve for a range of potentials and simulate a whole polarization plot.

#### Step 1: Stationary

- 1- In the Model Builder window, expand the Study 1 node, then click Step 1: Stationary.
- 2- In the Settings window for Stationary, click to expand the Study extensions section.
- 3- Locate the Study Extensions section. Select the Auxiliary sweep check box.
- 4- Click Add.
- 5- In the table, enter the following settings in the picture.
- 6- In the Model Builder window, click Study 1.
- 7- In the Settings window for Study, locate the Study Settings section.
- 8- Clear the Generate default plots check box.
- 9- On the Model toolbar, click Compute.

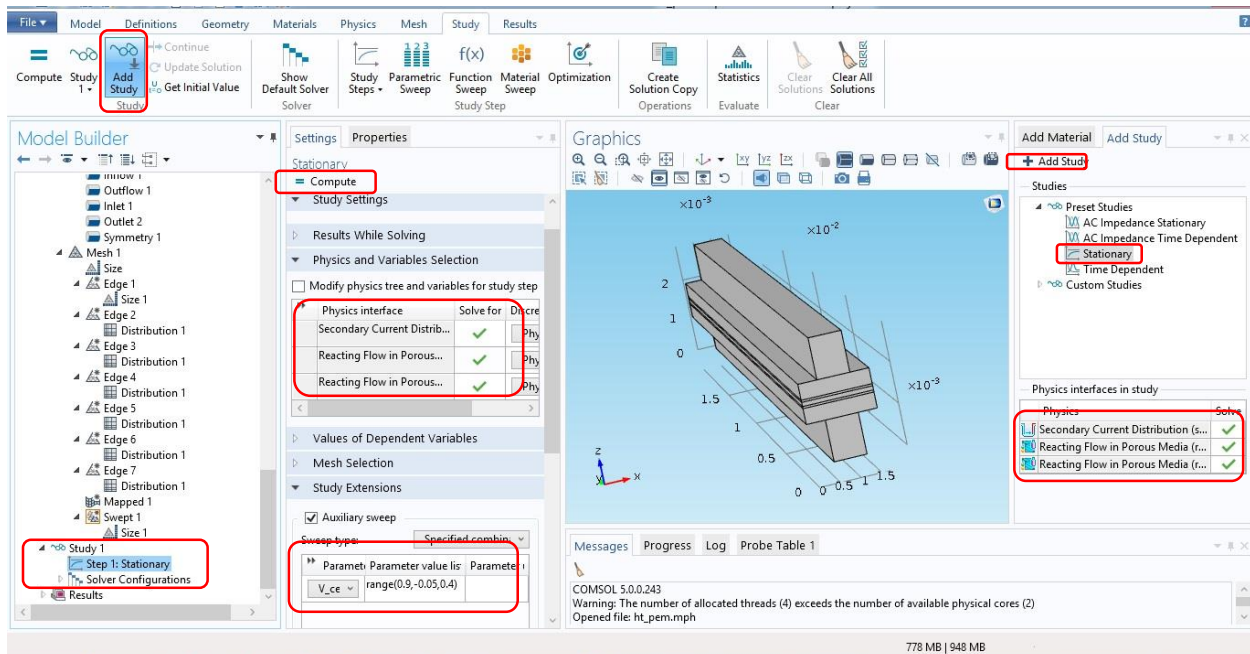

Figure 5.28 Adding & Making & Computing Study

## 5.7 Results

In the Model Builder window, expand the Results node.

### Probe Plot Group 1

Modify the probe plot as follows to reproduce the polarization plot in Figure 5.29.

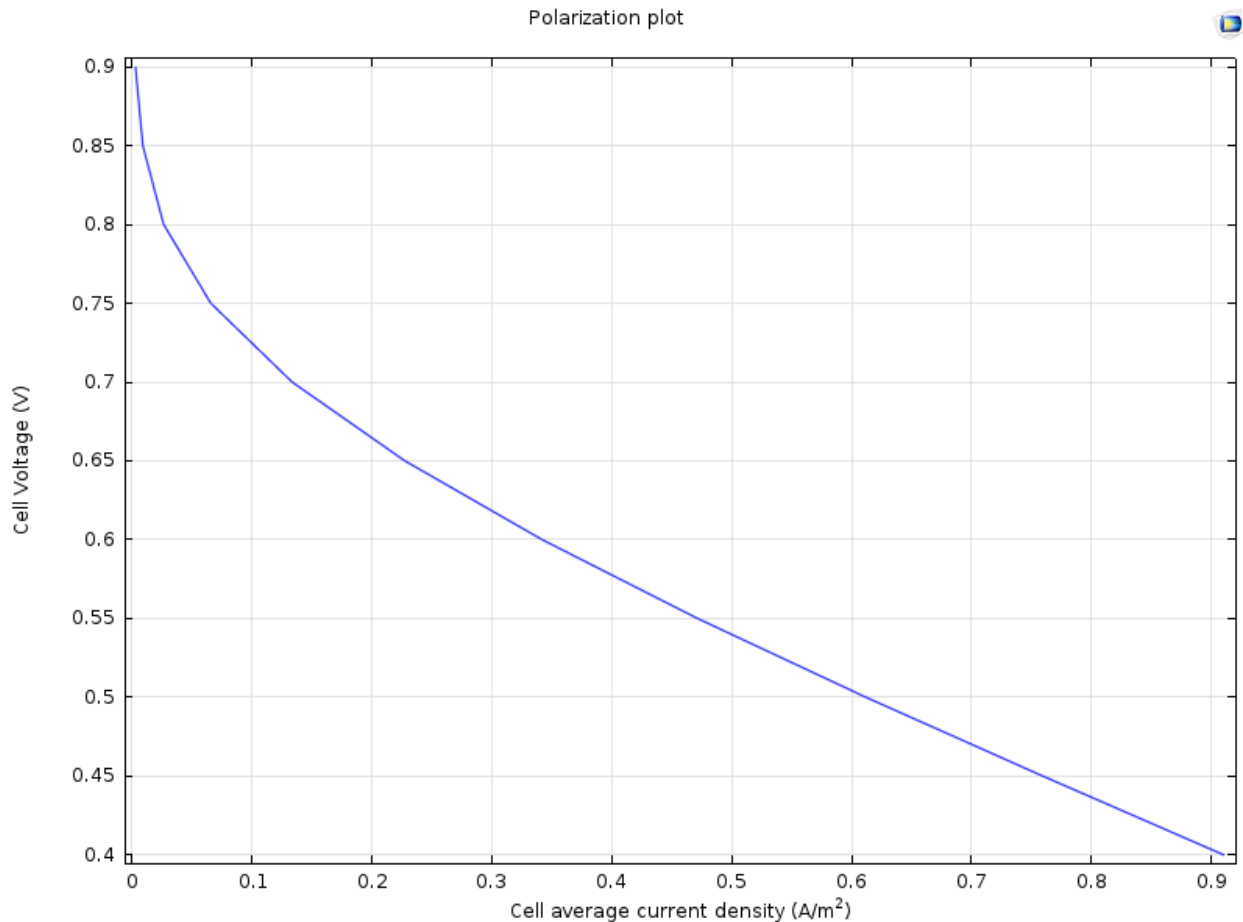

Figure 5.29 Polarization plot

- 1- In the Model Builder window, expand the Results>Probe Plot Group 1 node, then click Probe Table Graph 1.
- 2- In the Settings window for Table Graph, locate the Data section.
- 3- From the x-axis data list, choose  $\text{siec.iv\_per1}/((W\_ch+W\_rib)*L)/1e4$  (A/m<sup>2</sup>), Domain Probe 1.
- 4- In the Columns list, select V<sub>cell</sub>.

- 5- In the Model Builder window, click Probe Plot Group 1.
- 6- In the Settings window for 1D Plot Group, click to expand the Title section.
- 7- From the Title type list, choose Manual.
- 8- In the Title text area, type Polarization plot.
- 9- Locate the Plot Settings section. Select the x-axis label check box.
- 10- In the associated text field, type Cell average current density ( $\text{A/cm}^2$ ).
- 11- Select the y-axis label check box.
- 12- In the associated text field, type Cell Voltage (V).
- 13- On the 1D plot group toolbar, click Plot.

## Data Sets

Next, reproduce the ionic current plot of Figure 4.30. Begin by creating a Cut Plane data set.

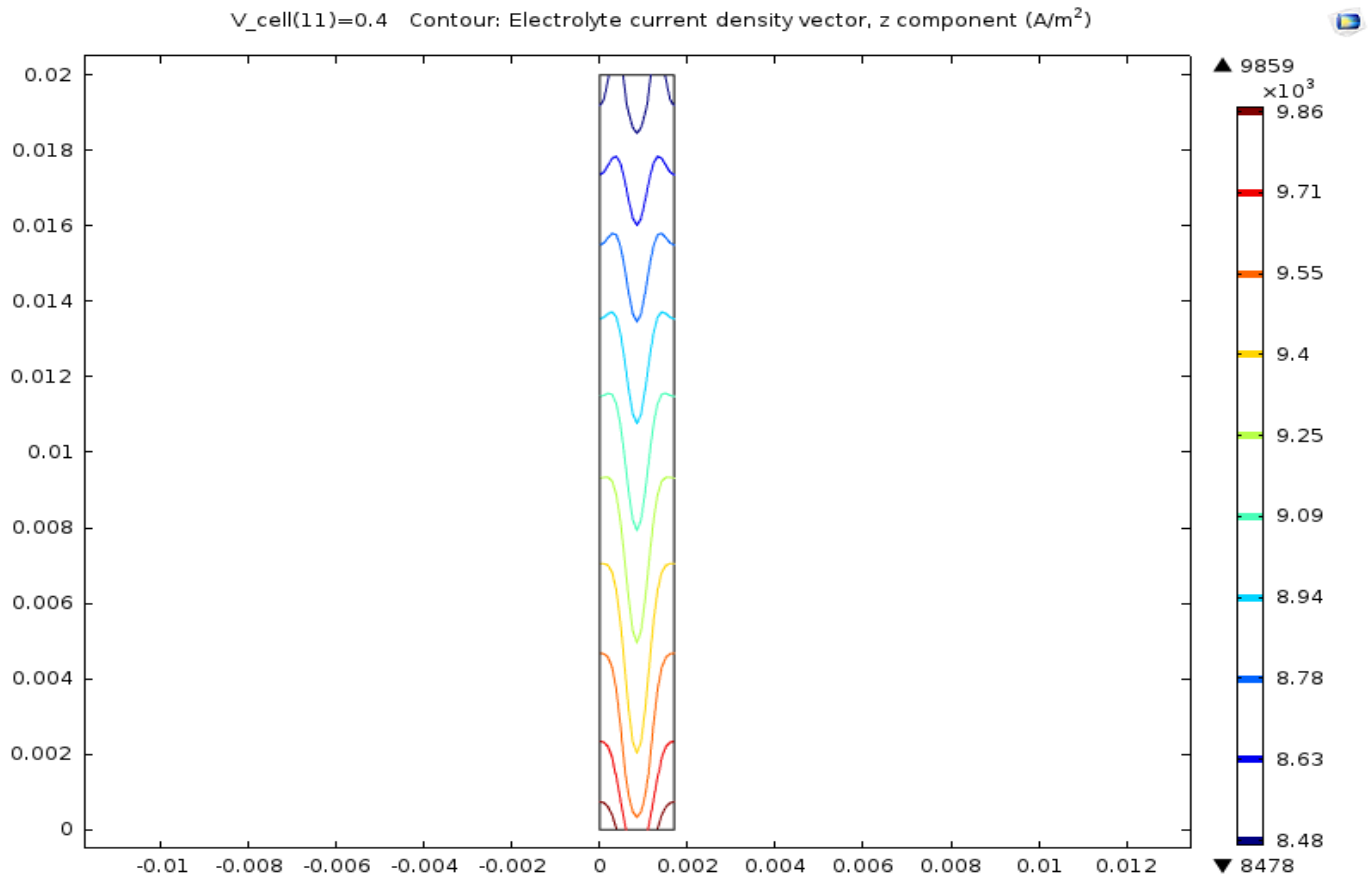

Figure 5.30 Ionic current in the polymer membrane at 0.4 V.

Figure 4.30 shows the ionic current in the z direction at the center of the membrane for 0.4 V.

In the y direction the current density is lower towards the outlet

(due to lower reactant concentrations).

In the x direction the current density is highest in the region close to the channel, where the reactant concentrations are higher, but the current density is reduced towards the very center of the channel.

This is due to Ohmic drops in the GDLs.

### Steps

- 1- On the Results toolbar, click Cut Plane.
- 2- In the Settings window for Cut Plane, locate the Plane Data section.
- 3- From the Plane list, choose xy-planes.
- 4- In the z-coordinate text field, type  $H_{ch}+H_{gdl}+H_{electrode}+H_{membrane}/2$ .

### 2D Plot Group 2

- 1- On the Results toolbar, click 2D Plot Group.
- 2- In the Model Builder window, under Results right-click 2D Plot Group 2 and choose Contour.
- 3- In the Settings window for Contour, click Replace Expression in the upper-right corner of the Expression section. From the menu, choose Component 1>Secondary Current Distribution>Electrolyte current density vector>sec.IIz - Electrolyte current density vector, z component.
- 4- Locate the Levels section. In the Total levels text field, type 10.
- 5- On the 2D plot group toolbar, click Plot.

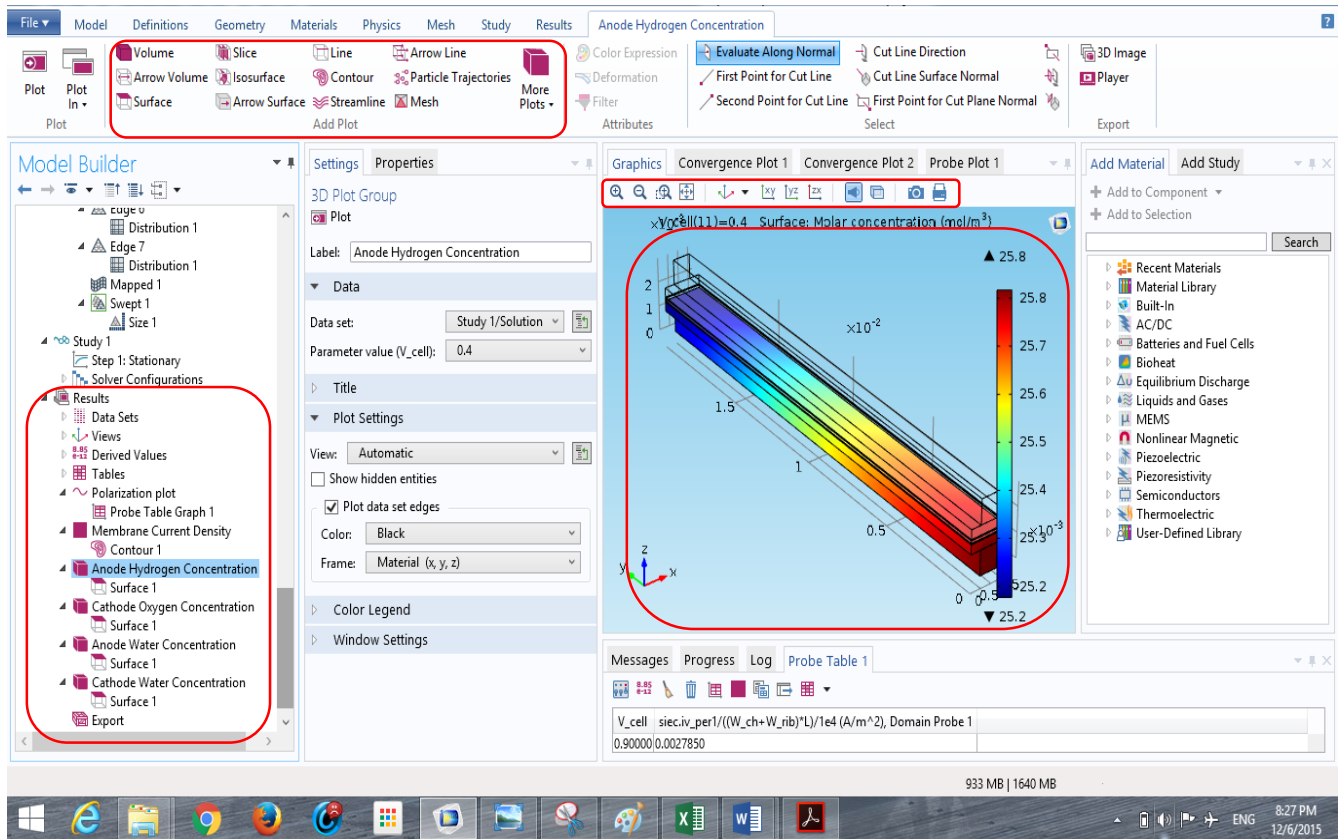

Figure 5.31 Result Window components

### 3D Plot Group 3

The remaining instructions reproduce the hydrogen and water concentration plots shown in Figure 5.32 and Figure 5.33.

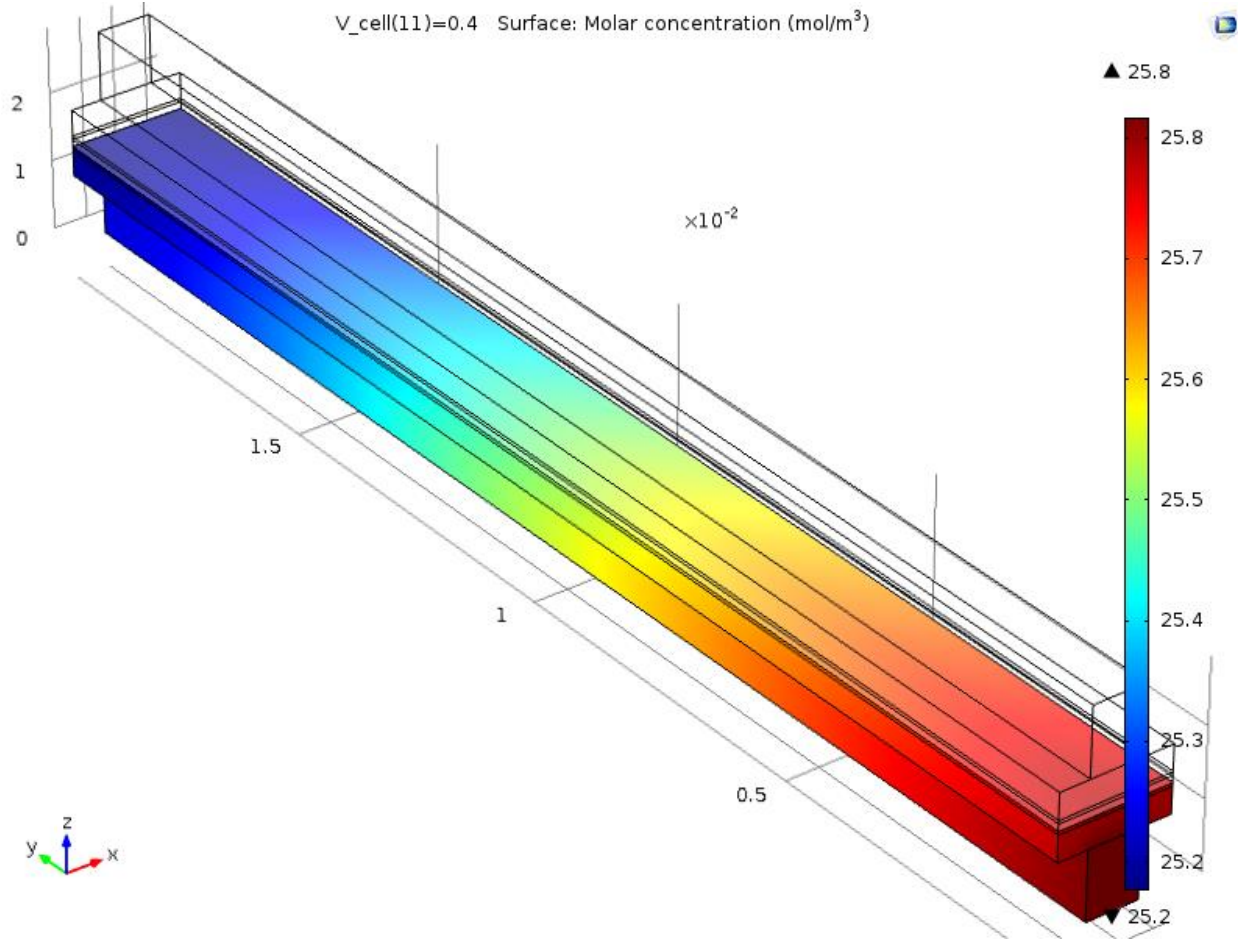

Figure 5.32 oxygen concentration at the cathode (bottom) in the cell at 0.4 V.

Figure 5.32 and Figure 5.33

shows the hydrogen and oxygen concentrations for the same voltage level.

The oxygen concentration is significantly lower in the porous electrode and towards the end of the flow channel compared to the inlet level.

For the anode the trend is the same but the hydrogen concentration level is more uniform.

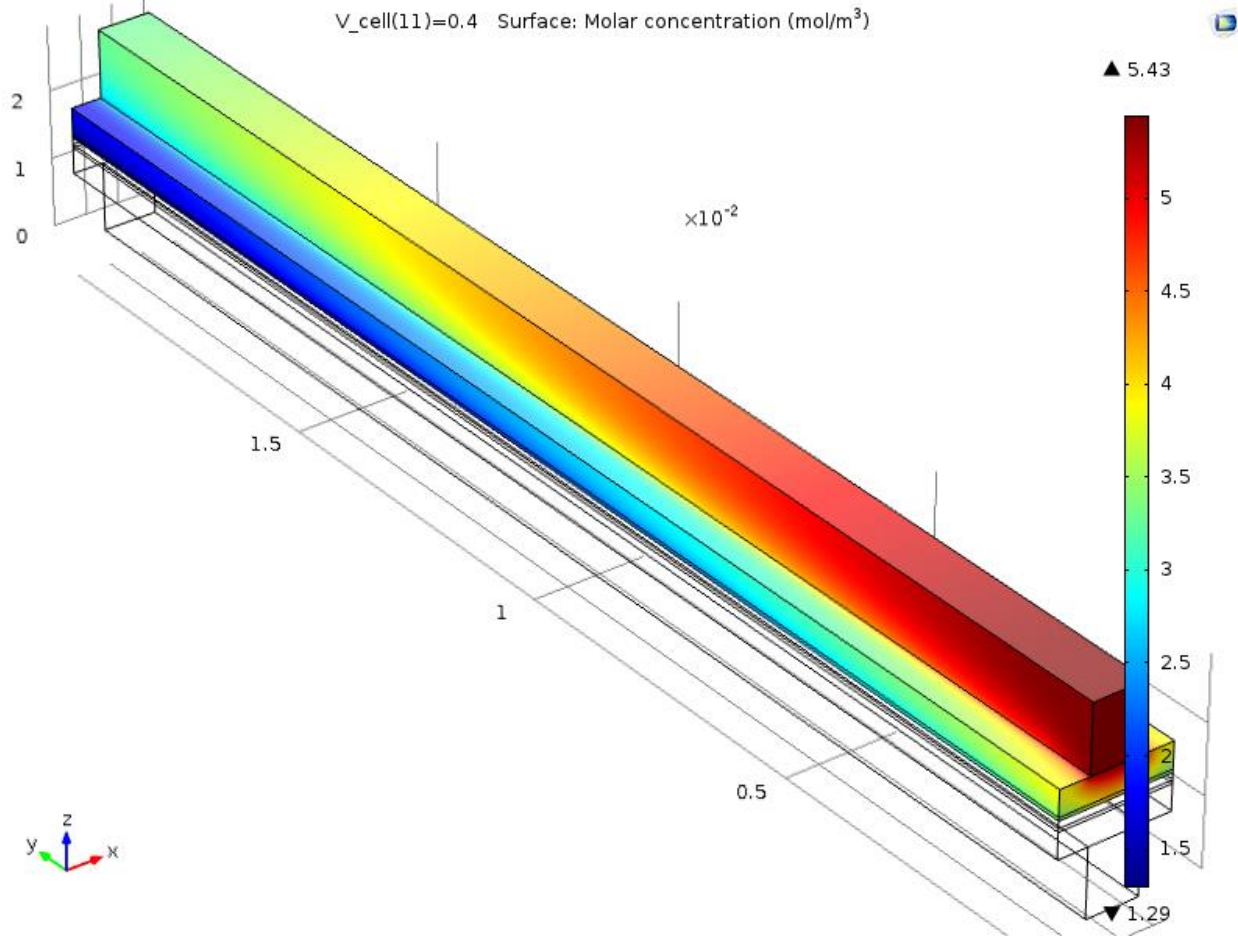

Figure 5.33 Hydrogen concentration at the anode (top) in the cell at 0.4 V.

- 1- On the Model toolbar, click Add Plot Group and choose 3D Plot Group.
- 2- In the Model Builder window, under Results right-click 3D Plot Group 3 and choose Surface.
- 3- In the Settings window for Surface, click Replace Expression in the upper-right corner of the Expression section. From the menu, choose Component 1>Reacting Flow in Porous Media (Transport of Concentrated Species)>Species wH2>rfs.c\_wH2 – Molar concentration.
- 4- On the 3D plot group toolbar, click Plot.

Compare the result with the upper plot in Figure 5.32 & Figure 5.33.

### **3D Plot Group 4**

- 1- On the Model toolbar, click Add Plot Group and choose 3D Plot Group.
- 2- In the Model Builder window, under Results right-click 3D Plot Group 4 and choose Surface.
- 3- In the Settings window for Surface, click Replace Expression in the upper-right corner of the Expression section. From the menu, choose Component 1>Reacting Flow in Porous Media 2 (Transport of Concentrated Species)>Species wO2>rfcs2.c\_wO2 - Molar concentration.
- 4- On the 3D plot group toolbar, click Plot.

Compare with the lower plot in Figure 5.32 & Figure 5.33.

### **3D Plot Group 5**

- 1- On the Model toolbar, click Add Plot Group and choose 3D Plot Group.
- 2- In the Model Builder window, under Results right-click 3D Plot Group 5 and choose Surface.
- 3- In the Settings window for Surface, click Replace Expression in the upper-right corner of the Expression section. From the menu, choose Component 1>Reacting Flow in Porous Media (Transport of Concentrated Species)>Species wH2Oa>rfcs.c\_wH2Oa - Molar concentration.
- 4- On the 3D plot group toolbar, click Plot.

The plot should look like the lower one in Figure 5.34 & Figure 5.35.



### 3D Plot Group 6

- 1 On the Model toolbar, click Add Plot Group and choose 3D Plot Group.
  - 2 In the Model Builder window, under Results right-click 3D Plot Group 6 and choose Surface.
  - 3 In the Settings window for Surface, click Replace Expression in the upper-right corner of the Expression section. From the menu, choose Component 1>Reacting Flow in Porous Media 2 (Transport of Concentrated Species)>Species wH2Oc>rfcs2.c\_wH2Oc - Molar concentration.
  - 4 On the 3D plot group toolbar, click Plot.
- Compare with the upper plot in Figure 5.34 & Figure 5.35.

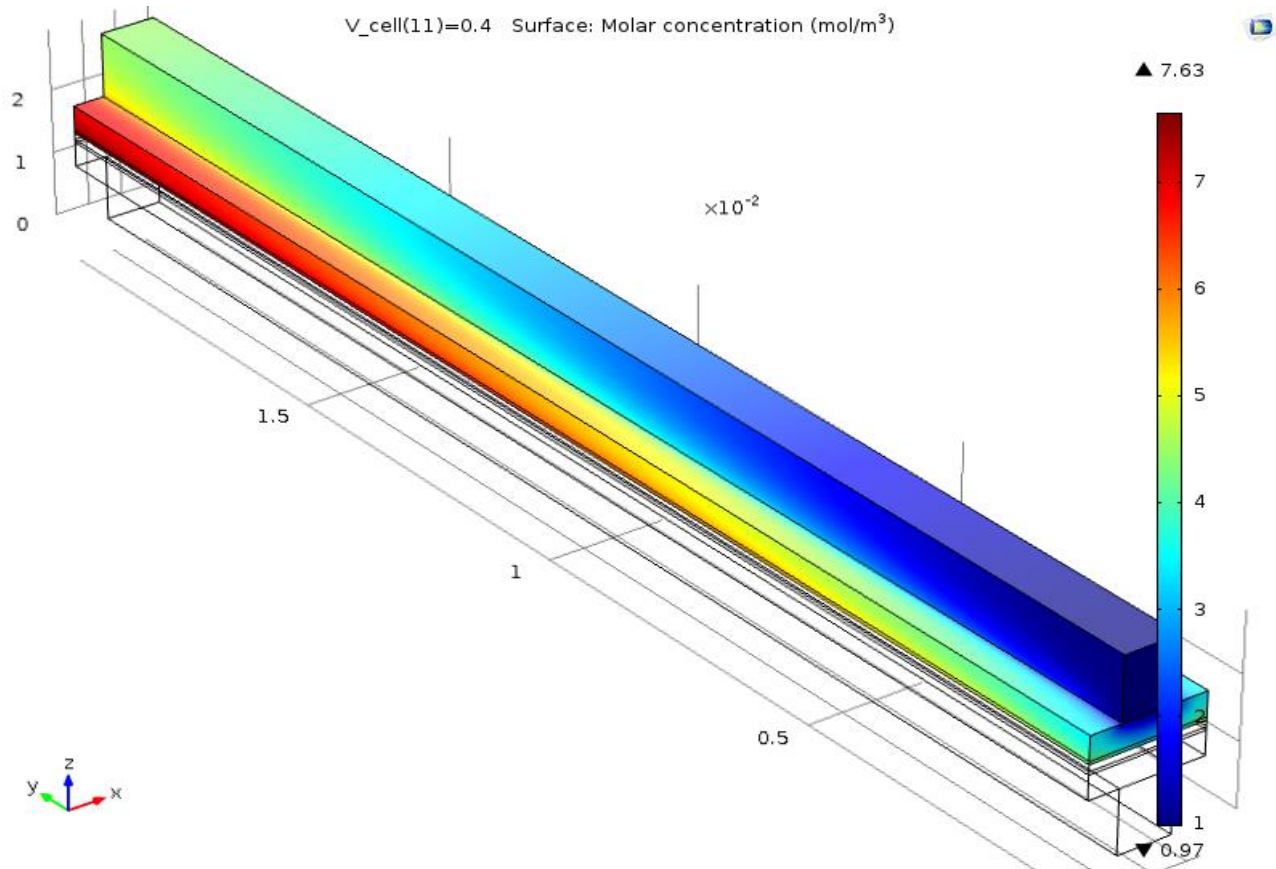

Figure 5.34 Water concentration on the anode (top) in the cell at 0.4 V.

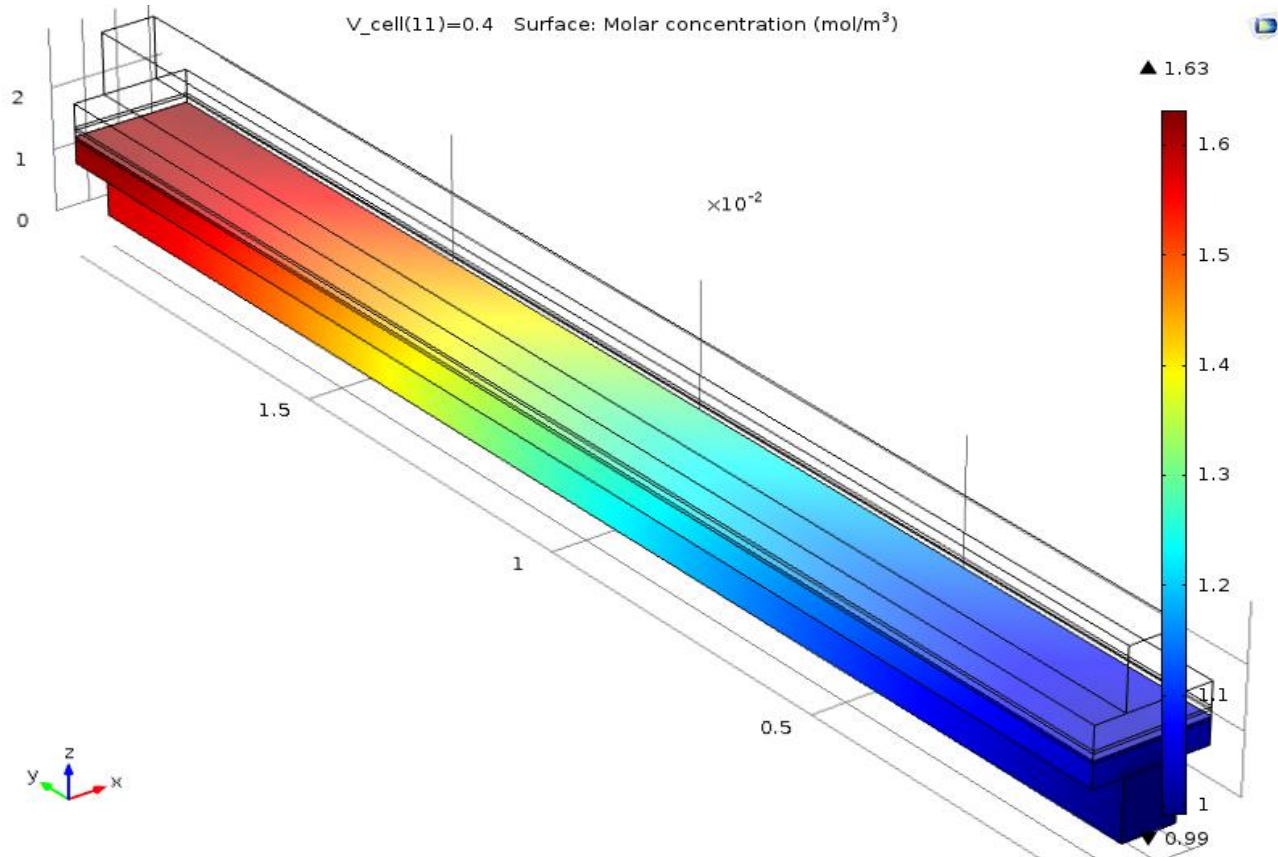

Figure 5.35 Water concentration on the cathode (bottom) in the cell at 0.4 V.

Figure 5.34 & Figure 5.35

Shows the water concentration in the cell for the same voltage level.

The concentration increase due to water production at the cathode is much larger than the effect of removing hydrogen from the gas stream at the anode for these flow and current levels.

## **Chapter 6**

### **Comparison Between PEMFC & SOFC and Conclusions**

---

#### **6.1 Introduction**

#### **6.2 Efficiency vs voltage Curve**

#### **6.3 Efficiency vs Operating Pressure Curve**

#### **6.4 Efficiency vs Operating Temperature Curve**

#### **6.5 Net Power Vs Voltage Curve**

#### **6.6 Net Power Vs Operating Pressure Curve**

#### **6.7 Net Power Vs Operating Temperature Curve**

#### **6.8 Conclusions**

## 6.1 Introduction

In this chapter focus on the results of simulation in previous chapters of proton exchange membrane fuel cell and solid oxide fuel cell and make comparison between them.

There is very different between PEMFC and SOFC in materials and working operation cooling system and power source to run each one.

Instead of different between PEMFC and SOFC the comparison is treat the simulation results only.

## 6.2 Efficiency vs voltage Curve

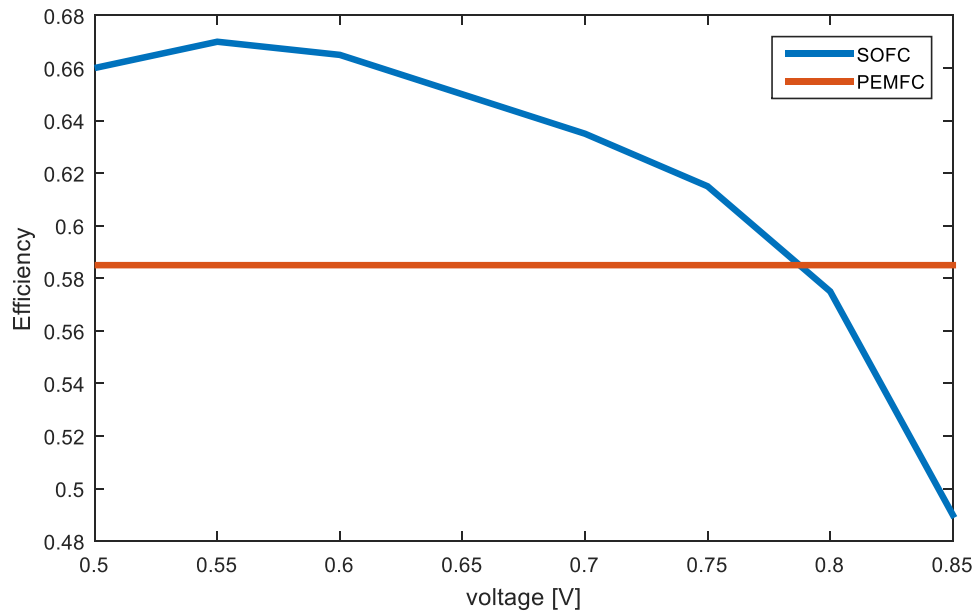

Figure 6.1 Efficiency vs voltage Curve

Figure 6.1 shows the efficiency with voltage curve for both SOFC and PEMFC from the curve. We conclude that the efficiency of SOFC increases to its highest value at 0.555 V then it starts decreasing reaching a value of 0.5 whereas the PEMFC keeps its efficiency constant when changing voltage which equals 0.59.

### 6.3 Efficiency vs Operating Pressure Curve

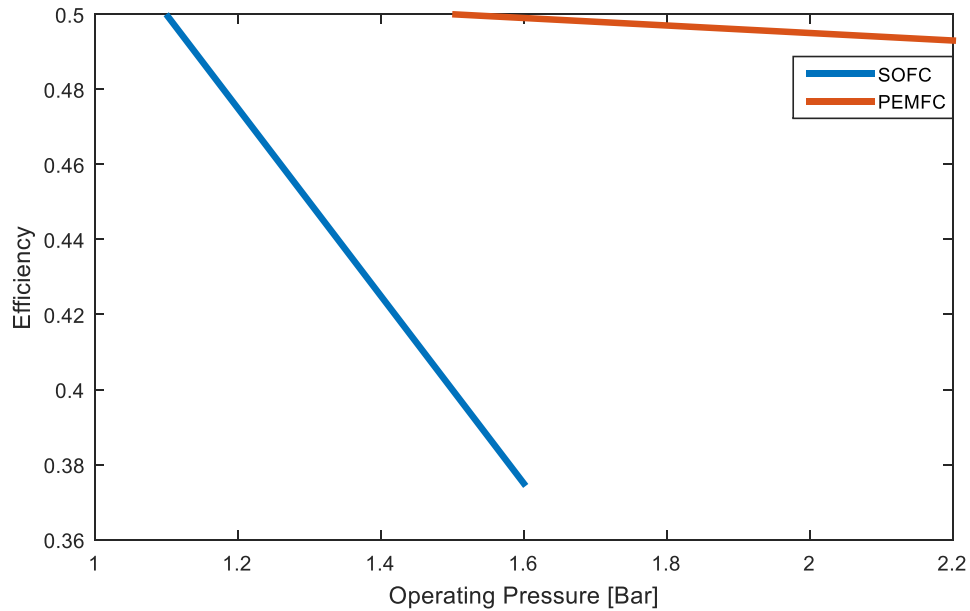

Figure 6.2 Efficiency vs Operating Pressure Curve

Figure 6.2 shows the Efficiency Vs Operating Pressure Curve from the figure 6.4 above we conclude that the efficiency of SOFC decreases with increasing pressure as when the pressure is equal to 1.2 bars the efficiency equals 0.5 but when pressure is increased to 1.6 bar the efficiency equals 0.38, on the other hand the PEMFC roughly decreases when compared to SOFC where it reaches 0.49 at 2.2 bar.

## 6.4 Efficiency vs Operating Temperature Curve

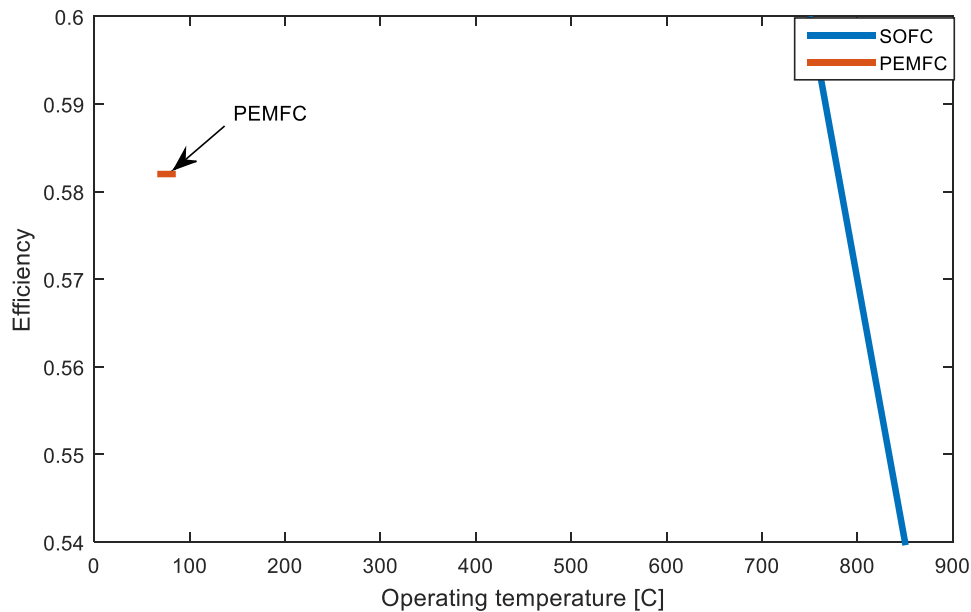

Figure 6.3 Efficiency vs Operating Temperature Curve

Figure 6.3 shows Efficiency Vs Operating Temperature Curve we conclude from the figure that SOFC operates at very high temperatures and that its efficiency decreases when increasing the temperature as it reaches almost 0.6 and decreases to 0.54 but the PEMFC operates at lower temperatures at almost 80 to 100 C and its efficiency doesn't decrease when increasing temperature and it reaches a value of almost 0.582.

## 6.5 Net Power Vs Voltage Curve

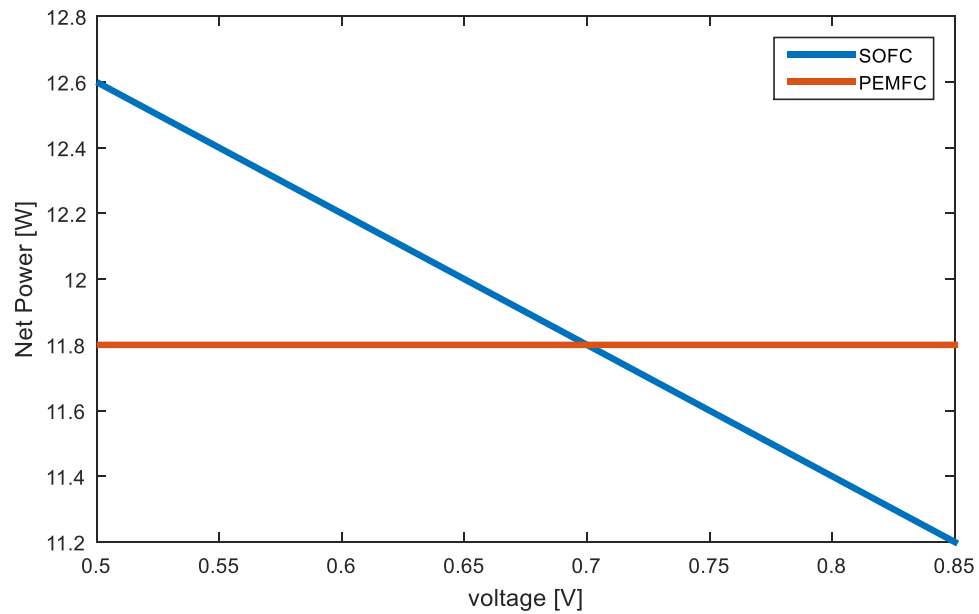

Figure 6.4 Net Power Vs Voltage Curve

Figure 6.4 shows Net Power Vs Voltage Curve from the figure it is observed that the SOFC reduces power with increasing voltage whereas the PEMFC remains constant at a value of 11.8 Watts.



## 6.6 Net Power Vs Operating Pressure Curve

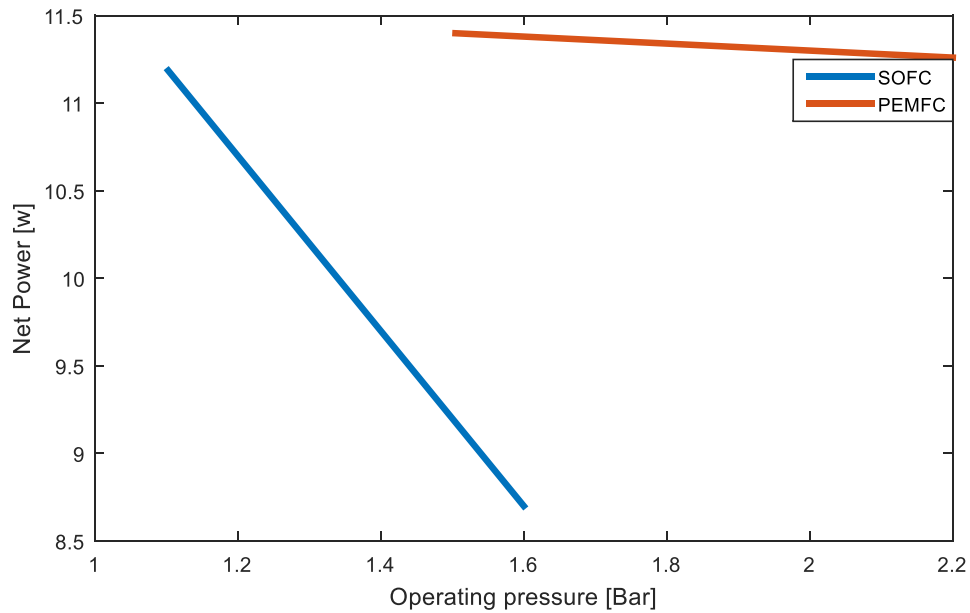

Figure 6.5 Net Power Vs Operating Pressure Curve

Figure 6.5 Net Power Vs Operating Pressure Curve from the following curve we conclude that the decreasing in the PEMFC is far less than in SOFC when comparing the power with pressure as the SOFC is nearly 11.3 watts reaching 8.56 watts when increasing pressure but the BMFC doesn't decrease much and reduces from 11.4 to 11.2 at 2.2 bars.

## 6.7 Net Power Vs Operating Temperature Curve

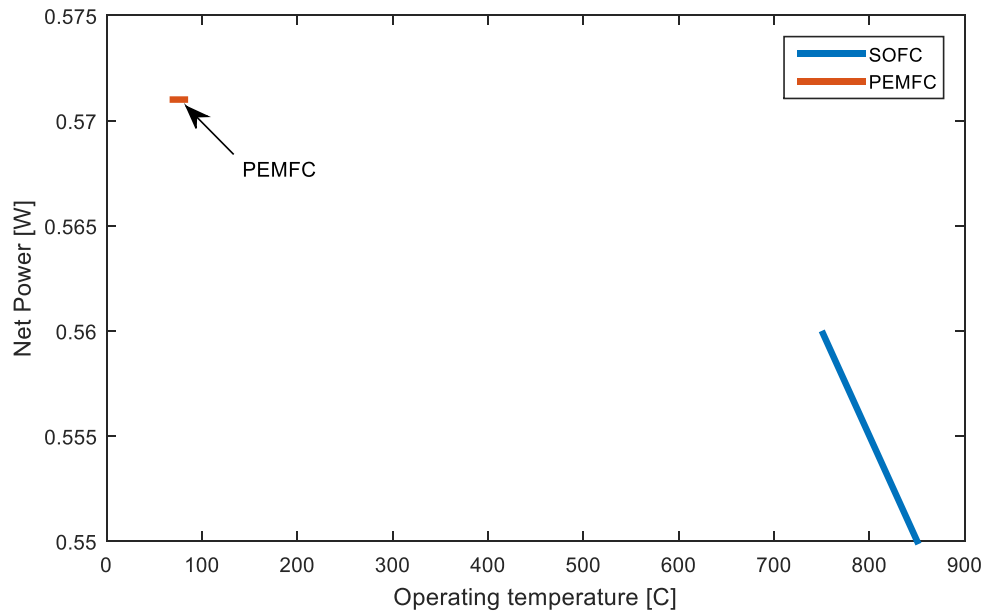

Figure 6.6 Net Power Vs Operating Temperature Curve

Figure 6.6 shows Net Power Vs Operating Temperature Curve from this curve we conclude that the PEMFC operates at very low temperatures when compared with other types and that the power generated when the temperature changes as its value is 0.572 but the SOFC operates at higher temperatures and decreases its power dramatically when increasing temperature.

## 6.8 Conclusions

The polarization curves obtained by simulations show that the voltage in SOFC decreases slowly compared with PEMFC which will lead to better efficiency in SOFC.

The operating temperature of SOFC is higher (in the range 800-1000 C) compared with PEMFC (in the range 80-150 C), therefore, the efficiency of PEMFC remains almost constant over the operating temperature while the SOFC efficiency decreases significantly due to the high operating temperature. Moreover, the high operating temperature of SOFC will need careful thermal treatment in order to be safe.

Considering all the operating variables (pressure, voltage and temperature) the efficiency of PEMFC is better than SOFC, therefore in PEMFC we have better continuity, power and life cycle.

Finally, the results obtained by the simulations recommend the use of PEMFC in real life applications, which is inline and coherent with the available literature.

## References

- [1] International Energy Agency. World Energy Outlook 2009. IEA Publications, 2009.
- [2] [www.eia.gov/todayinenergy/detail.cfm?id=19571](http://www.eia.gov/todayinenergy/detail.cfm?id=19571)
- [3] European Environment Agency, 2011. URL: [www.eea.europa.eu/](http://www.eea.europa.eu/).
- [4] National Aeronautics and Goddard Institute for Space Studies Space Administration, 2011. URL: [www.giss.nasa.gov/](http://www.giss.nasa.gov/).
- [5] [www.static2.businessinsider.com/image54818b9aecad04b97b390b1b-854-470gray\\_2.jpg](http://www.static2.businessinsider.com/image54818b9aecad04b97b390b1b-854-470gray_2.jpg)
- [6] Carbon Dioxide Information Analysis Center, 2011. URL <http://cdiac.ornl.gov/>
- [7] [www.ces.fau.edu/nasaimages/EnergyGreenhouseGasPercentages.jpg](http://www.ces.fau.edu/nasaimages/EnergyGreenhouseGasPercentages.jpg)
- [8] European Commission. Energy 2020. Publications Office of the European
  
- [9] Fuel Cell Fundamentals. Ryan O'hayre, Suk-won Cha, Whitney Colella, Fritz B. Prinz. Second Edition, 2009
- [10] Solid Oxide Fuel Cells, Materials properties and performance. Jeffrey W.Fergus, Rob Hui, Xianhio Li, David P. Wilkinson, Jiujin Zhang, 2009
  
- [12] [www.osakagas.co.jp/en/rd/fuelcell/sofc/sofc/img/sofc\\_02\\_img02.jpg](http://www.osakagas.co.jp/en/rd/fuelcell/sofc/sofc/img/sofc_02_img02.jpg)
- [13] [www.osakagas.co.jp/en/rd/fuelcell/sofc/sofc/img/sofc\\_02\\_img03.jpg](http://www.osakagas.co.jp/en/rd/fuelcell/sofc/sofc/img/sofc_02_img03.jpg)
  
- [14] Multiphysics Models for the Simulation of Solid Oxide Fuel Cells, Marcia Garcia Camprub 2011

## PEMFC Parameters

Name	Expression	Unit	Description
L	0.02	[m]	Cell length
H_ch	1.00E-03	[m]	Channel height
W_ch	7.87E-04	[m]	Channel width
W_rib	9.09E-04	[m]	Rib width
H_gdl	3.80E-04	[m]	GDL width
H_electrode	5.00E-05	[m]	Porous electrode thickness
H_membrane	1.00E-04	[m]	Membrane thickness
eps_gdl	0.4		GDL porosity
kappa_gdl	1.18E-11	[m <sup>2</sup> ]	GDL permeability
sigma_gdl	222	[S/m]	GDL electric conductivity
wH2_in	0.743		Inlet H2 mass fraction (anode)
wH2O_in	0.023		Inlet H2O mass fraction (cathode)
wO2_in	0.228		Inlet oxygen mass fraction (cathode)
U_in_anode	0.2	[m/s]	Anode inlet flow velocity
U_in_cathode	0.5	[m/s]	Cathode inlet flow velocity
mu_anode	1.19E-05	[Pa*s]	Anode viscosity
mu_cathode	2.46E-05	[Pa*s]	Cathode viscosity
MH2	0.002	[kg/mol]	Hydrogen molar mass
MN2	0.028	[kg/mol]	Nitrogen molar mass
MH2O	0.018	[kg/mol]	Water molar mass
MO2	0.032	[kg/mol]	Oxygen molar mass
D_H2_H2O	$9.15e-5*(T/307.1[K])^{1.75}$ [m <sup>2</sup> /s]		H2-H2O Binary diffusion coefficient
D_N2_H2O	$2.56e-5*(T/307.15[K])^{1.75}$ [m <sup>2</sup> /s]		N2-H2O Binary diffusion coefficient
D_O2_N2	$2.2e-5*(T/293.2[K])^{1.75}$ [m <sup>2</sup> /s]		O2-N2 binary diffusion coefficient
D_O2_H2O	$2.82e-5*(T/308.1[K])^{1.75}$ [m <sup>2</sup> /s]		O2-H2O binary diffusion coefficient
T	180+273.15[K]		Cell temperature
p_ref	1.01E+05	[Pa]	Reference pressure
V_cell	0.9		Cell voltage
cO2_ref	40.88	[mol/m <sup>3</sup> ]	Oxygen reference concentration
cH2_ref	40.88	[mol/m <sup>3</sup> ]	Hydrogen reference concentration
eps_l	0.3		Electrolyte phase volume fraction
eps_cl	1-eps_l-eps_gdl		Open volume fraction for gas diffusion in porous electrodes
kappa_cl	kappa_gdl/5		Permeability (porous electrode)
sigma_m	9.825	[S/m]	Membrane conductivity

### SOFC Parameters

Name	Expression	Unit	Description
p_atm	1	[atm]	Atmospheric pressure
T	800	[degC]	Temperature
mu	3.00E-05	[Pa*s]	Viscosity, air
dp_a	2	[Pa]	Pressure drop, anode
dp_c	6	[Pa]	Pressure drop, cathode
i0_a	0.1	[A/m^2]	Exchange current density, anode
i0_c	0.01	[A/m^2]	Exchange current density, cathode
Sa_a	1.00E+09	[1/m]	Specific surface area, anode
Sa_c	1.00E+09	[1/m]	Specific surface area, cathode
V_pol	0.05	[V]	Initial cell polarization
perm_a	1.00E-10	[m^2]	Anode permeability
perm_c	1.00E-10	[m^2]	Cathode permeability
Eeq_a	0	[V]	Equilibrium voltage, anode
Eeq_c	1	[V]	Equilibrium voltage, cathode
V_cell	Eeq_c-Eeq_a-V_pol		Cell voltage
kleff_a	1	[S/m]	Electrolyte effective conductivity, anode
kseff_a	1000	[S/m]	Solid effective conductivity, anode
kleff_c	1	[S/m]	Electrolyte effective conductivity, cathode
kseff_c	1000	[S/m]	Solid effective conductivity, cathode
kl	5	[S/m]	Electrolyte conductivity
ks	5000	[S/m]	Current collector conductivity
vh2	6.00E-06		Kinetic volume, H2
vo2	1.66E-05		Kinetic volume, O2
vn2	1.79E-05		Kinetic volume, N2
vh2o	1.27E-05		Kinetic volume, H2O
Mh2	2	[g/mol]	Molar mass, H2
Mo2	32	[g/mol]	Molar mass, O2
Mn2	28	[g/mol]	Molar mass, N2
Mh2o	18	[g/mol]	Molar mass, H2O
kd	3.16E-08	[m^2/s]	Reference diffusivity
e_por	0.4		Porosity
Dh2h2o	$kd \cdot (T[1/K])^{1.75} / (p\_atm[1/Pa] \cdot (vh2^{1/3} + vh2o^{1/3})^2) \cdot (1[kg/mol]/Mh2 + 1[kg/mol]/Mh2o)^{0.5}$		Diffusivity, H2-H2O
Do2h2o			Diffusivity, O2-N2

	$kd \cdot (T[1/K])^{1.75} / (p\_atm[1/Pa] \cdot (v_{o2}^{1/3} + v_{n2}^{1/3})^2) \cdot (1[\text{kg/mol}]/M_{o2} + 1[\text{kg/mol}]/M_{n2})^{0.5}$		
Do2n2	$kd \cdot (T[1/K])^{1.75} / (p\_atm[1/Pa] \cdot (v_{h2o}^{1/3} + v_{n2}^{1/3})^2) \cdot (1[\text{kg/mol}]/M_{h2o} + 1[\text{kg/mol}]/M_{n2})^{0.5}$		Diffusivity, N2-H2O
Dn2h2o	$D_{h2h2o} \cdot e\_por^{1.5}$		Effective diffusivity, H2-H2O
Dh2h2oeff	$D_{o2h2o} \cdot e\_por^{1.5}$		Effective diffusivity, O2-H2O
Do2h2oeff	$D_{o2n2} \cdot e\_por^{1.5}$		Effective diffusivity, O2-N2
Do2n2eff	$D_{n2h2o} \cdot e\_por^{1.5}$		Effective diffusivity, N2-H2O
Dn2h2oeff	0.4		Inlet weight fraction, H2 at anode
w_h2ref	0.15		Inlet weight fraction, O2 at cathode
w_o2ref	0.37		Inlet weight fraction, H2O at cathode
w_h2oref	$p\_atm / (R\_const \cdot T)$		Total molar concentration
c_tot	$c\_tot \cdot (w\_o2ref/M_{o2}) / (w\_o2ref/M_{o2} + w\_h2oref/M_{h2o} + (1-w\_o2ref-w\_h2oref)/M_{n2})$		Reference concentration, O2 at cathode
c_o2ref	$c\_tot \cdot (w\_h2ref/M_{h2}) / (w\_h2ref/M_{h2} + (1-w\_h2ref)/M_{h2o})$		Reference concentration, H2 at anode
c_h2ref	$c\_tot \cdot ((1-w\_h2ref)/M_{h2o}) / (w\_h2ref/M_{h2} + (1-w\_h2ref)/M_{h2o})$		Reference concentration, H2O at anode
c_h2oref	5.00E-04	[m]	Gas flow channel width
W_channel	5.00E-04	[m]	Rib width
W_rib	1.00E-04	[m]	Gas diffusion electrode thickness
H_gde	1.00E-04	[m]	Electrolyte thickness
H_electrolyte	5.00E-04	[m]	Gas flow channel height
H_channel	1.00E-02	[m]	Flow channel length

## Appendix A

### Fuel cell operating principle

#### A.1: chemical reaction on the electrodes:

The reaction below shows the chemical for hydrogen as fuel:

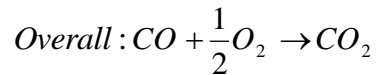
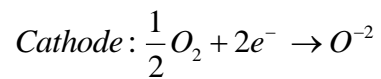
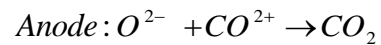
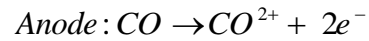

#### A.2: fuel cell thermodynamics

$$\Delta G = \Delta G_{\text{products}} - \Delta G_{\text{reactants}}$$

where:

$\Delta G$ : is the Gibbs free energy

$\Delta G_o : E_o * n_e F$

Where  $E_o$  : cell voltage at start

$n_e$ : number of electrons

F: faraday's constant

F=1



$$E_{CELL} = \frac{\Delta G_O}{neF} + \frac{RT}{neF} \ln \left[ \frac{P_{H_2} P_{O_2}^2}{P_{H_2O}^2} \right]$$

Where:

R: gas constant

T: temperature

$P_{H_2}$ : partial pressure for hydrogen

$P_{O_2}$ : partial pressure for oxygen

$P_{H_2O}$ : partial pressure for water

### A.3 Voltage loss

When the Fuel Cell is under load (a current is flowing), the voltage supplied at the electrodes will be different from the  $E_{cell}$ . The dependency of these losses on temperature, current density and species concentrations mainly determine the characteristics of a Fuel Cell. The output voltage is therefore lower than the circuit voltage when the FC is operated.

Three main mechanisms of voltage losses exist:

1. Activation polarization loss ( $\eta_{act}$ ),
2. Ohmic loss ( $\eta_{ohmic}$ ),
3. And concentration/diffusion loss ( $\eta_{con}$ ).

Exchange efficiency ( $\eta_{con}$ ). At low current level, the Ohmic loss becomes less significant, the increase in output voltage is mainly due to the activity of the chemicals ( $\eta_{act}$ ).

The output voltage of a cell,  $V_{cell}$  can, therefore, be written as:

$$V_{cell} = E_{cell} - \eta_{act} - \eta_{ohmic} - \eta_{con}$$

Where:

$\eta_{act}$ : Activation polarization loss.

$\eta_{ohmic}$ : Ohmic loss.

$\eta_{con}$ : concentration/diffusion loss.

### A.3.1 activation losses

$$\eta_{act} = \frac{RT}{\beta neF} \ln \frac{i}{i_o}$$

Where:

$\beta$ : constant.

$i$ : Current density.

$i_o$ : Exchange current density at an electrode/electrolyte interface.

$$i = 2 * i_o, k \sinh\left(\frac{neF\eta_{act,k}}{RT}\right) \rightarrow \eta_{act,k} = \frac{2RT}{neF} \sinh^{-1}\left(\frac{i}{2i_o, k}\right)$$

Where:

$k$ : Cp/Cv

### A.3.2 Ohmic loss ( $\eta_{ohmic}$ )

$$\eta_{Ohmic} = i * R_{ohm}$$

Where:

$i$ : Current density.

$R_{ohm}$ : ohmic resistance

$$R_{ohm} = Ra + Re + Rc + Ri$$

Where:

$Ra$ : Anode resistance.

$Re$ : Electrolyte resistance.

$Rc$ : Cathode resistance.

$Ri$ : Interconnector resistance.

### A.3.3 Concentration/diffusion loss ( $\eta_{con}$ )

$$\eta_{con} = m e^{(nifc)}$$

Where:

m: mass.

nifc: current per unit area for fuel cell.