

Palestine Polytechnic University



*College of Engineering and Technology
Electrical Engineering Department*

*Graduation Project
Wireless Control and Processing of ECG Signal
for Medical Diagnosis of Patients*

*Project Team
Hanifah Bader Hiba Tahboub
Howayda Bader*

*Project Supervisor
Prof. Daoud Zatar*

*Hebron-Palestine
2007*

جامعة بوليتكنك فلسطين
الخليل - فلسطين
كلية الهندسة و التكنولوجيا
دائرة الهندسة الكهربائية والحاسوب

أسم المشروع

Wireless Control and Processing of ECG Signal
For Medical Diagnosing Of Patients

أسماء الطلبة

هبة وجيه طهبوب

هويدا سعد الله بدر

حنيفة أنور بدر

بناء على الأنظمة المتبعة في كلية الهندسة و التكنولوجيا وإشراف ومتابعة المشرف المباشر على المشروع وموافقة اعضاء اللجنة الممتحنة تم تقديم هذا المشروع إلى دائرة الهندسة الكهربائية وذلك للوفاء بمتطلبات درجة البكالوريوس في الهندسة تخصص هندسة أنظمة الحاسوب وهندسة الأجهزة الطبية.

توقيع المشرف

.....

.....

توقيع اللجنة الممتحنة

.....

.....

.....

توقيع رئيس الدائرة

.....

Dedication

To our dads, moms, sisters, and brothers; thank you for always being there for us. This could not have been done without your support.

Project Team

Acknowledgment

We are so grateful to Prof.Daoud I-Zatari for his supervision, support, advices, and constructive criticism throughout this work of the project.

This work wouldn't have been accomplished without the help of Dr.Radi Masri whom we will always be thankful for his efforts in reviewing this document, giving useful remarks, and providing new ideas.

Finally, we would like to thank all those in the Electrical and Computer Department who didn't hesitate to give any help or to answer any question.

Abstract

The Electrocardiography (ECG) is an essential diagnostic tool that measures and records the electrical activity of the heart. A wide range of heart conditions can be detected when interpreting the recorded ECG signals. The commonly used ECG-machine is expensive and stationary and because of this, it is impractical. This is especially the case when trying to do research or perform daily monitoring of patients who are at risk of having heart problems without keeping them at the hospital

The aim of this project was to develop a small wireless sensor system to be able to perform ECG on patients at home, without the need for hospitalization. This system is to be more mobile and flexible than classic ECG recording machine. It is intended to provide an alternative to the current wired-based ECG devices for monitoring patients remotely. The system can be connected to the patient mobile phone which sends the ECG signal to any place such as hospital PC using the GPRS technology.

The first phase of the project was to design and implement the interfacing circuit. It was accomplished successfully, and the result of the analogue part was acceptable.

The next phase of the project was to transmit ECG data from the mobile phone to a PC located centrally within a hospital or a medical center for continuous monitoring of the patient. To do this, a microcontroller was used and a special software was developed to convert and transmit the analogue signal of the ECG from the mobile phone. It was also necessarily to develop a software to facilitate receiving the data from the mobile phone and to display it on the PC.

A successful interface between the mobile and a microcontroller was accomplished. A data was sent from the microcontroller to the mobile were the later acknowledges the receiving of the data. Further work is still required for the system.

Table of Contents

Cover page	I
Approved page	II
Dedication	III
Acknowledgment	IV
Abstract	V
Table of contents	VI
List of tables	VIII
List of figures	VIII
Abbreviation	IX
Chapter One : Introduction	1
1.1 General Idea and the Importance of the Project	2
1.2 Objectives of the Project	3
1.3 Literature Review	3
1.4 Project Schedule	3
1.5 Total Cost and Budget	5
1.6 Risk Management	6
1.7 Report Contents	6
Chapter Two : Theoretical Background	8
2.1 Circulatory System	9
2.2 Heart	9
2.2.1 Heart Contraction	10
2.2.2 The Cardiac Cycle	11
2.2.3 The Heart's Conduction System	11
2.3 Electrocardiogram (ECG)	14
2.3.1 ECG Leads	14
2.3.2 ECG Frequency	20
2.3.3 Waves and Intervals	20
2.4 Theories	24
2.4.1 Bio-potential	24
2.4.2 Electrode Theory	26
2.4.3 Sampling Theory	26
2.5 Project Components	26
Chapter Three : Project Design	27
3.1 Project Detailed Objectives	29
3.2 Design Options	29
3.3 Realization Approach	29
3.4 Suggested Block Diagram	29
3.4.1 DC Voltage and Current Regulation	30
3.4.2 ECG Electrode	30
3.4.3 ECG Module	31
3.4.4 Mobile Serial Connection cable	34
3.4.5 Mobile Phone	35
3.4.6 Hospital PC	35
3.5 Project Software	35
3.5.1 C Language	36

3.5.2 J2ME language:	36
3.5.3 LabVIEW	36
Chapter Four : Technical Project Design	37
4.1 Project Phases	38
4.2 Description of the Project Phases	38
4.2.1 Design and Construction of the System Circuit:	38
4.2.3 Signal Sampling and Processing	46
4.2.4 Mobile Interface with PIC	49
4.2.5 Application Programs	49
Chapter Five: System Implementation and Testing	55
5.1 Hardware Testing	56
5.1.1 Voltage and Current Regulation Circuit Testing	56
5.1.2 Instrumentation Amplifier	56
5.1.3 Driven Right Leg Circuit	57
5.1.4 Band Pass Filter Result	57
5.1.5 Inverting Amplifier Circuit Test	58
5.1.6 PIC and Mobile Interfacing Circuit Testing	60
5.2 Software Testing	60
5.2.1 Analog to Digital (ADC) and USART Code	60
5.2.2 AT Commands Code Testing	60
5.2.3 LABVIEW	62
Chapter Six : Conclusions and Future Work	63
6.1 Conclusions	64
6.2 Problems	65
6.2.1 Hardware Problems	65
6.2.2 Software Problems	66
6.3 Future Work	66
References	67
Appendences	69

List of Tables

Table 1.1: Time Schedule Table	4
Table 1.2: Timing Diagram	4
Table 1.3 Budget	5

List of Figures

Figure (2.1): Heart Chambers.	10
Figure (2.2): Heart's Conduction System	12
Figure (2.3): Sequence Of Electrical Stimulation Signal From SA Node	13
Figure (2.4): ECG Wave	14
Figure (2.5): Positive Electrodes, Depolarization Wavefronts and	14

Complexes Displayed on the ECG	
Figure (2.6): Positive Electrodes, Depolarization Wavefronts and Complexes Displayed on the ECG	15
Figure (2.7): Positive Electrodes, Depolarization Wavefronts and Complexes Displayed on the ECG	15
Figure (2.8): Einthoven's Triangle	16
Figure (2.9): Lead I Wave	16
Figure (2.10): Lead II Wave	17
Figure (2.11): Placement of the Limb Leads	18
Figure (2.12): Placement of the Limb Leads	19
Figure (2.13): Various QRS Complexes with Nomenclature	22
Figure (2.14): Bio-potential Measurement	24
Figure (2.15): Bio-potential Mechanism	25
Figure (3.1): Block diagram	30
Figure (3.2): Ag-AgCl Electrode	31
Figure (3.3): Electrode Equivalent Circuit	31
Figure (3.4): ECG Module	31
Figure (3.5): Processing & Amplifying Sub-block	32
Figure (3.6): Instrumentation Amplifier	32
Figure (4.1): Voltage and Current Regulation Circuit 11	39
Figure (4.2): 4 volts indicator circuit19	40
Figure (4.3): Instrumentation Amplifier Circuit	41
Figure (4.4): Band Pass Filter	42
Figure (4.5): Inverting Amplifier	43
Figure (4.6): Right Leg Driven Circuit 14	43
Figure (4.7): Optical Isolation Circuit19	44
Figure (4.8): PIC Circuit	45
Figure (4.9): PIC Software Flowchart.	48
Figure (4.10): 6610i serial cable15	49
Figure (4.11): Mobile Code Flowchart	51
Figure (4.12): hospital PC LabVIEW Front panel	53
Figure (4.13): LabVIEW Flowchart	54
Figure (5.1): Instrumentation Amplifier Result	56
Figure (5.2): Driven Right Leg Circuit	57
Figure (5.3): Band Pass Filter Result	58
Figure (5.4): Inverting Amplifier Circuit Test	59
Figure (5.5): Test Result Taken from 28 Years Male Volunteer	59
Figure (5.6): Analog to Digital (ADC) and USART Code Testing	60
Figure (5.7): AT Command Testing at Hyperterminal	61
Figure (5.8): LABVIEW Front Panel	62

Abbreviations:

AVF :Augmented Vector Foot

AVL: Augmented Vector Left

AVR :Augmented Vector Right

CMRR: Common Mode Rejection Ratio

DC : Direct current

ECG : Electrocardiography

GPRS : General Packet Radio Service

PIC : Peripheral Interface Controller

IC : Integrated Circuit

Chapter One

Introduction

1.1 General Idea and the Importance of the Project

Electrocardiography (ECG) is an electrical recording of the heart activity and is usually prescribed to investigate heart diseases. An electrical impulse initiates muscle contraction, which results in heart beating. The spacing between pulses provides a measure of the heart's rhythm, whereas the amplitude of the pulses is an indicator of pumping strength. By observing the ECG waveform, the heart condition of the patients can be diagnosed by doctors. It has been in clinical use for the diagnosis and monitoring of heart abnormalities for almost a century.

It remains the best and least invasive method for diagnosing heart problems. ECG measurement systems have evolved and have become more reliable and able to perform a wider range of functions. Although a wireless system for measurement and monitoring of ECG has yet to be developed. The purpose of this project is to develop an ECG monitoring system that is not bulky and readily portable.¹⁷

A prototype of a portable integrated wireless ECG system will be designed and developed. This device is sensor-based, wireless-enabled and will be used to log, analyze and monitor home based heart patients. It is intended to provide an alternative to the current wired-based ECG devices for monitoring patients. This prototype will increase the flexibility and mobility of the patients.

The device will be constructed using an ECG circuit, which receiving the analog signal from the patient's body and transfers it to a Microcontroller (PIC Microcontroller) where the signal will be sampled and digitized. The PIC will transfer the digital signal to a serially connected mobile phone. After that the signal will be transmitted through GPRS (a packet-based wireless communication service that promotes data rates from 56 up to 114 Kbps and continuous connection to the Internet for mobile phone and computer users) to a PC in the hospital where the signal will be analyzed.

The system is intended to be used for average at-risk heart patients who don't have to stay at the hospital and in the same time need monitoring. The device will give them the comfort of their home and the necessary monitoring they need.

1.2 Objectives of the Project

The main objective of this project is to design, develop and implement a wireless ECG system that records the ECG signal for at risk heart patients and transmitting it through the GPRS to a hospital where it can be monitored.

In addition this project has the following educational objectives:

- 1- To develop a small, affordable, portable device that requires minimal power.
- 2- To facilitate monitoring of at risk, at home, heart patients at anytime.
- 3- To improve the quality of patients life, and allow them to function without having to stay for long periods at the hospital.

1.3 Literature Review

- 1- An Ultra-Wearable, Wireless, Low Power ECG Monitoring System.

This paper¹⁶ presents a description and evaluation of a wireless version of a system based on electrodes that do not require skin preparation in advance, and also do not require pastes or gels to make electrical contact to the skin. The ECG sensor here includes not only the sensing device, but also a signal conditioning circuit such as low noise amplifier.

- 2-Wireless ECG based on Bluetooth protocol: design and implementation.

In this paper¹⁷ we present a low cost, portable system with wireless transmission for real time ECG acquisition, archiving and visualization both in a mobile phone and a PC. They have implemented the acquisition module and the visualization tool for the mobile device and the PC. Results were send by Bluetooth module to both PC & mobile device.

- 3-Small wireless ECG with Bluetooth™ communication to a PDA

This thesis¹⁸ investigates the possibilities to create a small sized ECG sensor system that can be wirelessly connected to a handheld device that can graphically present the ECG-signals.

1.4 Project Schedule

At beginning of the semester, the time was divided to accomplish the work on the specified tasks and according to the schedule shown in Table (1.1) and Table (1.2) below.

Table (1.1): Time Schedule Table

Task#	Task	Duration (weeks)
1.	Getting ideas and important information about the project	1
2.	Literature review	2-3
3.	Project design and block diagram design	4-10
4.	IC,s determining and fetching	11-16
5.	J2me programming language studding	17-20
6.	At command studding	17-22
7.	Hardwire building and testing	18-30
8.	Software algorithms design	20
9.	PIC ADC software Programming	24
10.	Mobile application Programming	20-26
11.	PC application Programming	24-28
12.	At command testing between computer and mobile	23
13.	Interfacing PIC with mobile (At command testing)	23-32
14.	Data analysis and conclusion with recommendation. Final documentation	26-30
15.	Documentation ,Power point, and prepare for presentation	25-32

Table (1.2): Time Diagram

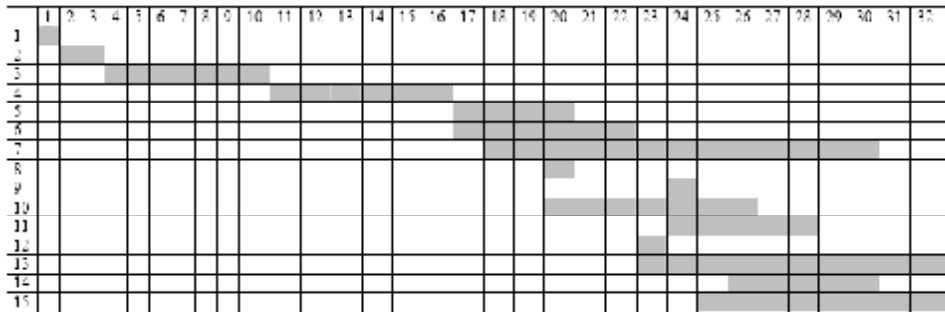

1.5 Total Cost and Budget

This section lists the overall cost of the components that was considered in implementing the system. Table (1.3) below shows all details.

Table (1.3): Budget

<i>Part</i>	<i>Quantity</i>	<i>Price (NIS)</i>	<i>Total Price (NIS)</i>
AD620	1	20	20
LM358	2	3	6
Mobile Phone	1	200	200
PIC 18F4550	1	50	50
PC	1	3000	3000
LabView Software	-	-	-
C Compiler	-	-	-
J2me Software	-	-	-
Ag-AgCl Electrode	33	0.5	16.5
ECG Lead and Connector	1	1500	1500
Printed Board	1	100	100
Capacitor	7	1	7
Resistor	24	0.5	12
Zener	1	2	2
IED	1	0.5	0.5
MA723C	2	8	16
Rechargeable Battery and a Charger	2	160	160
Transistor	1	0.5	0.5
Trimmer	2	5	10
IC Base Pin	100	0.25	25
Project Box	1	70	70
Effort	3 persons	1000	3000
MAX8214	1	17	17
Serial Cable	1	20	20
Laboratory Rent	-	-	-
Sim Card	1	99	99
Total Cost			= 8331.5 NIS

1.6 Risk Management

Anticipated Potential Risks

This section lists possible risks the team considered in the project plan, as well as techniques for minimizing these risks.

- Loss of an advisor – Loss of a team member: To minimize this risk, all team members were aware of each others' tasks and roles, to assume and distribute those tasks should make the loss less critical.
- Loss of data/code – All data should be backed up in multiple sites, on multiple systems.
- Over-ambitious project – To minimize this risk, the team consulted with faculty advisor before making decisions, and discuss related issues inside the group before the final design is submitted.

1.7 Report Contents

The documentation for this project is divided into seven chapters. The followings explain briefly the contents of each chapter:

Chapter 1: Introduction

This chapter presents overview, literature review, project scheduling, and estimated cost, project risk.

Chapter 2: Theoretical Background

This chapter discusses the ECG physiology, electrode theory, theoretical hardware and software related to the project components, project integrity and theoretical background.

Chapter 3: Project Conceptual Design

This chapter includes the detailed project objectives, design options, project design, block diagram, and project interaction with the surrounding environment.

Chapter 4: Technical Project Design and Software

This chapter includes detailed description of project phases, subsystem detailed design, overall system design, user system interface ,software that transfer the signal using mobile (j2me), and flowchart which will be followed by the operator.

Chapter 5: System Implementation and Testing

This chapter includes testing of our design, which will be performed next semester.

Chapter 6: Conclusion and Future Work

This chapter includes expect results of our design which will be achieves next semester and the suggestions and future developments

Chapter Two

Theoretical Background

2.1 Circulatory System

The circulatory system (or cardiovascular system) is an organ system that moves nutrients, gases, and wastes to and from cells, and helps stabilize body temperature and pH to maintain homeostasis^[1].

Human circulatory system main parts:

- Heart
- Blood
- Blood vessels
- Lungs

These components can either belong to the systemic circulation or the pulmonary circulation. The systemic circulation is the main part of the circulatory system, while the pulmonary system oxygenates the blood.

2.2 Heart

The heart is the center of the cardio-vascular system. It receives oxygen deficient blood from the body; sends it to get a fresh supply of oxygen from the lungs; then pumps this oxygen rich blood back around the body.

It has approximately 70 beats per minute and 100,000 per day. Over 70 years the human heart pumps 2.5 billion times. Its size is that approximately of the clenched fist of its owner and it weighs between 200 to 400 grams, depending upon the sex of the individual^[2].

The heart is located in the chest cavity just posterior to the breastbone, between the lungs and superior to the diaphragm. The heart is surrounded by a fluid filled sac called the pericardium. Blood is pumped away from the heart through arteries and returns to the heart through veins. The major artery of the body is the aorta and the major veins of the body are the vena cava.

As it is shown in Figure (2.1), heart has four chambers:

- (1) Right atrium: receives oxygen-depleted blood from the body via the superior vena cava and the inferior vena cava and pumps it through the tricuspid valve into the right ventricle.
- (2) Right ventricle: receives oxygen-depleted blood from the right atrium and pumps it through the pulmonary valve into the lungs via the pulmonary artery.

- (3) Left atrium: receives oxygen-rich blood from the lungs via the pulmonary veins and pumps it through the mitral valve into the left ventricle.
- (4) Left ventricle: receives oxygen-rich blood from the left atrium and pumps it through the aortic valve to be delivered throughout the body, including to the heart muscle itself via the coronary arteries.

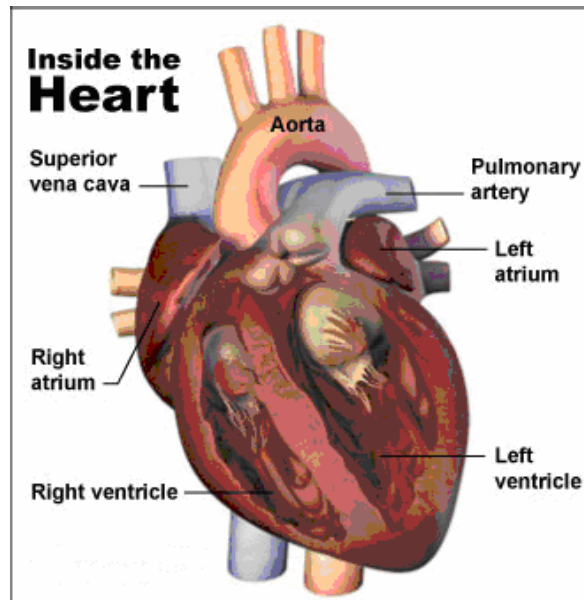

Figure (2.1): Heart ⁶

2.2.1 Heart Contraction

The contraction of the cardiac muscles is initiated by a specialized nervous tissue that serves as a built-in pacemaker that can function independently of the central nervous system, called the sinoatrial node (SA node) or the sinus node. It consists of a cluster of cells that are situated in the upper part of the wall of the right atrium (the right upper chamber of the heart). The electrical impulses are generated there.

The electrical signal generated by the SA node moves from cell to cell down through the heart until it reaches the atrioventricular node (AV node), which is a cluster of cells situated in the center of the heart between the atria and ventricles. The AV node serves as a gate that slows the electrical current before the signal is permitted to pass down through to the ventricles.

This delay (which is about a tenth of a second) ensures that the atria have a chance to fully contract before the ventricles are stimulated. After passing the AV node, the electrical current travels to the ventricles along special fibers embedded in the walls of the lower part of the heart called the atrioventricular bundle. At the base of the heart the atrioventricular bundles start to divide further into Purkinje fibers. When the impulses reach these fibers they trigger the muscle fibers in the ventricles to contract.

2.2.2 The Cardiac Cycle

When surgically removed from the body, the heart continues to beat for several hours provided it is supplied with the appropriate nutrients and salts. This is possible because the heart possesses its own specialized conduction system and can beat independently even after being separated from its nerve supply.

The extrinsic (arising external to the heart) nerve supply coming from the nervous system serves to modify and regulate the intrinsic (inherent to the heart itself) beating established by the heart.

2.2.3 The Heart's Conduction System

There are four basic components to the heart's conduction system

- (1) Sinoatrial node (SA node)
- (2) Inter-nodal fiber bundles
- (3) Atrioventricular node (AV node)
- (4) Atrioventricular bundle

These components are shown in Figure (2.2).

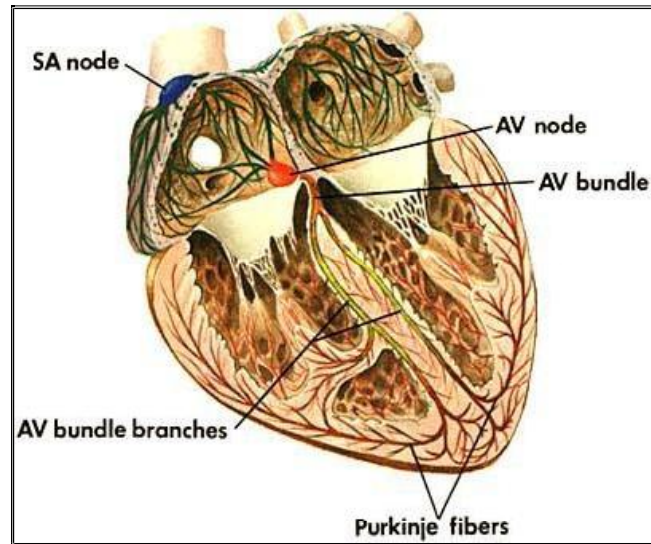

Figure (2.2): Heart's Conduction System⁷

The sinoatrial (SA) node is a small mass of specialized cardiac muscle situated in the superior aspect of the right atrium. It lies along the anterolateral margin of this chamber between the orifice of the superior vena cava and the auricle. The specialized cardiac muscle of the SA node is characterized by the property of automatic self-excitation and it initiates each beat of the heart. Therefore, the SA node is often referred to as the pacemaker of the heart.

Since the fibers of the SA node fuse with the surrounding atrial muscle fibers, the action potential generated in the nodal tissue spreads throughout both atria at a rate of approximately 0.3 meter per second and produces atrial contraction. Interspersed among the atrial muscle fibers are several inter nodal fiber bundles which conduct the action potential to the atrioventricular (AV) node with a greater velocity (approximately 1.0 meter per second) than ordinary atrial muscle. The AV node is located in the right atrium near the lower part of the interatrial septum. Here there is a short delay (approximately 0.1 second) in transmission of the impulse to the ventricles.

This is important because —as mentioned earlier— it permits the atria to complete their contraction and empty their blood into the ventricles before the ventricles contract. The delay occurs within the fibers of the AV node itself as well as in special junctional fibers that connect the node with ordinary atrial fibers.

Once the action potential leaves the AV node, it enters specialized muscle fibers called Purkinje fibers. These are grouped into a mass termed the atrioventricular (AV) bundle, or the bundle of His. The Purkinje fibers are very large and conduct the action potential at about six times the velocity of ordinary cardiac muscle (i.e., 1.5 to 4.0 meters per second). Thus the Purkinje fibers permit a very rapid and simultaneous distribution of the impulse throughout the muscular walls of both ventricles.

As the AV bundle leaves the AV node, it descends in the interventricular septum for a short distance and then divides into two large branches, the right and left bundle branches. Each of these descends along its respective side of the interventricular septum immediately beneath the endocardium and divides into smaller and smaller branches. Terminal Purkinje fibers extend beneath the endocardium and penetrate approximately one-third of the distance into the myocardium. Their endings terminate upon ordinary cardiac muscle within the ventricles, and the impulse proceeds through the ventricular muscle at about 0.3 to 0.5 meters per second. This results in a contraction of the ventricles that proceeds upward from the apex of the heart toward its base. The pathway taken by each action potential generated by the SA node is represented schematically as follow in Figure (2.3):

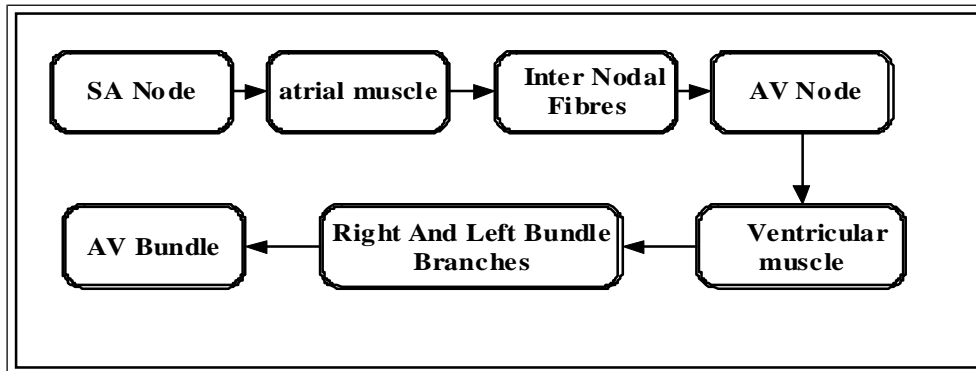

Figure (2.3): Sequence of Electrical Stimulation Signal from SA Node

The spontaneous generation of an action potential within the SA node initiates a sequence of events known as the cardiac cycle. Each cardiac cycle lasts approximately 0.8 second and spans the interval from the end of one heart contraction to the end of the subsequent heart contraction. Ordinarily this occurs about 72 times each minute.

2.3 Electrocardiogram (ECG)

An electrocardiogram (ECG or EKG, abbreviated from the German Elektrokardiogramm) is a graphic produced by an electrocardiograph, which records the electrical activity of the heart over time (Figure 2.4).

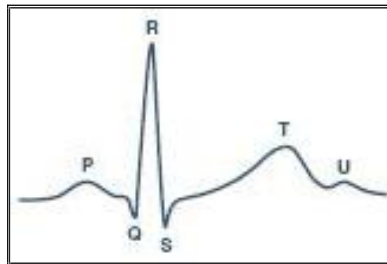

Figure (2.4): ECG Wave⁸

2.3.1 ECG Leads

The word lead has two meanings in electrocardiography:

- (1) The wire that connects an electrode to the electrocardiograph.
- (2) A combination of electrodes that form an imaginary line in the body along which the electrical signals are measured.

A lead records the electrical signals of the heart from a particular combination of recording electrodes which are placed at specific points on the patient's body. When a depolarization wavefront moves toward a positive electrode, it creates a positive deflection on the ECG in the corresponding lead (Figure 2.5).

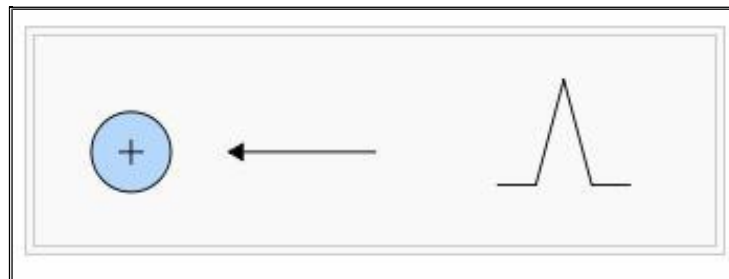

Figure (2.5): Positive Electrodes, Depolarization Wavefronts and Complexes Displayed on the ECG⁹

When a depolarization wavefront moves away from a positive electrode, it creates a negative deflection on the ECG in the corresponding lead (Figure 2.6).

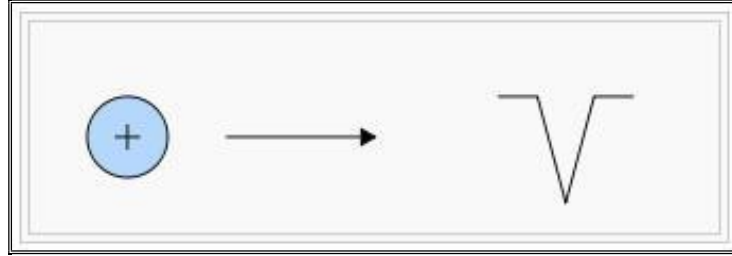

Figure (2.6): Positive Electrodes, Depolarization Wavefronts and Complexes Displayed on the ECG⁹

When a depolarization wavefront moves perpendicular to a positive electrode, it creates an equiphase (or isoelectric) complex on the ECG (Figure 2.7). It will be positive as the depolarization wavefront approaches (A), and then become negative as it passes by (B).

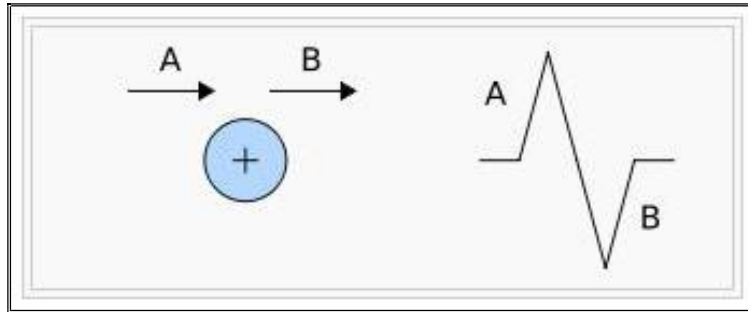

Figure (2.7): Positive Electrodes, Depolarization Wavefronts and Complexes Displayed on the ECG⁹

There are two types of leads, unipolar and bipolar. The former have an indifferent electrode at the center of the Einthoven's triangle at zero potential (Figure 2.8). The direction of these leads is from the "center" of the heart radially outward and includes the precordial (chest) leads and limb leads— VL, VR, & VF.

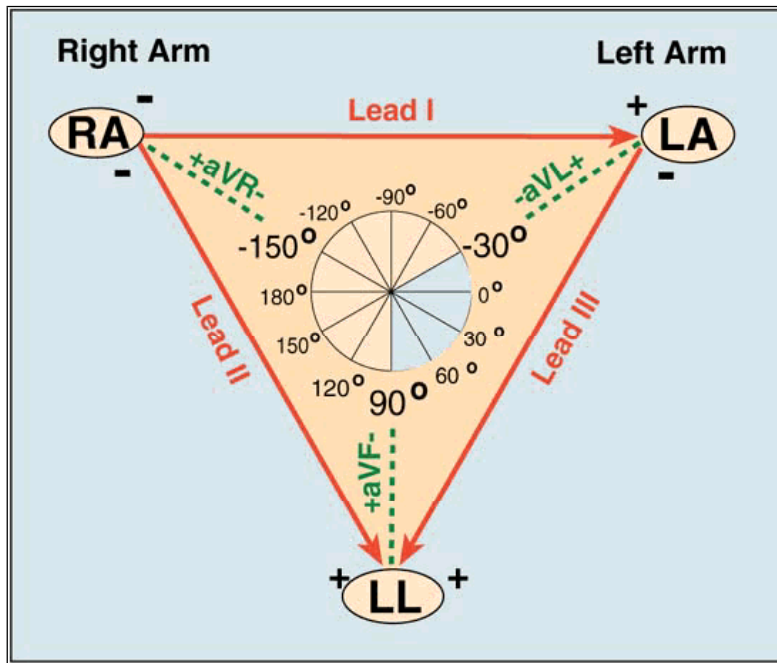

Figure (2.8): Einthoven's Triangle⁹

2.3.1.1 Leads Type

1- Limb leads that are divided into:

A) limb leads (Bipolar)

Lead I:

It is a dipole with the negative electrode on the right arm and the positive electrode on the left arm. Lead I wave is shown in Figure (2.9).

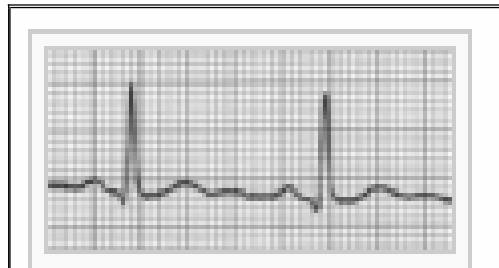

Figure (2.9): Lead I Wave⁹

Lead II:

It is a dipole with the negative electrode on the right arm and the positive electrode on the left leg. It is shown in Figure (2.10).

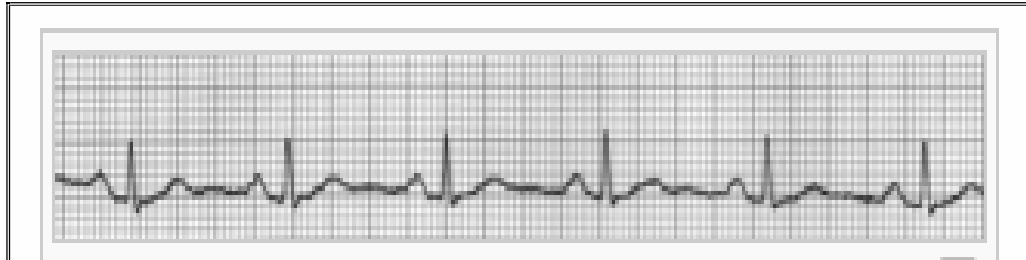

Figure (2.10): Lead II Wave⁹

Lead III:

It is a dipole with the negative electrode on the left arm and the positive electrode on the left leg.

B) Augmented limb leads (Unipolar)

They are derived from the same three electrodes as leads I, II, and III. However, they view the heart from different angles (or vectors) because the negative electrode for these leads is a modification of Wilson's central terminal, which is derived by adding leads I, II, and III together and plugging them into the negative terminal of the ECG machine.

This zeroes out the negative electrode and allows the positive electrode to become the "exploring electrode" or a unipolar lead. This is possible because Einthoven's Law states that $I + (-II) + III = 0$.

The equation can also be written $I + III = II$. It is written this way (instead of $I + II + III = 0$) because Einthoven reversed the polarity of lead II in Einthoven's triangle, possibly because he liked to view upright QRS complexes.

Lead aVR:

Has the positive electrode on the right arm. The negative electrode is a combination of the left arm electrode and the left leg electrode, which "augments" the signal strength of the positive electrode on the right arm.

Lead aVL:

Has the positive electrode on the left arm. The negative electrode is a combination of the right arm electrode and the left leg electrode, which "augments" the signal strength of the positive electrode on the left arm.

Lead aVF:

Has the positive electrode on the left leg. The negative electrode is a combination of the right arm electrode and the left arm electrode, which "augments" the signal of the positive electrode on the left leg.

Limb leads are shown in Figure (2.11) below.

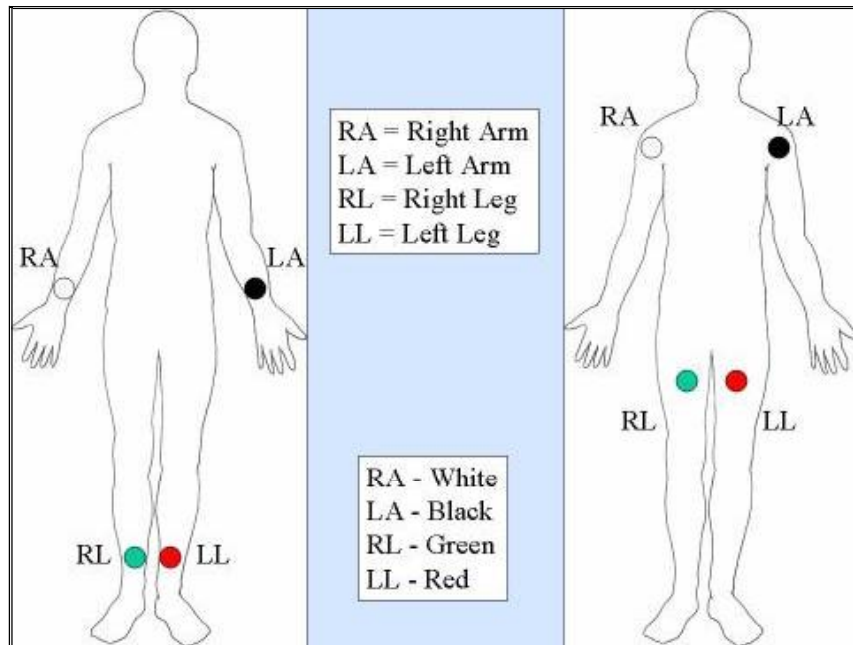

Figure (2.11): Placement of the Limb Leads⁹

2-Precordial:

The precordial leads V1, V2, V3, V4, V5, and V6 are placed directly on the chest. Because of their close proximity to the heart, they do not require augmentation. These leads are considered to be unipolar.

The precordial leads view the heart's electrical activity in the so-called horizontal plane. The heart's electrical axis in the horizontal plane is referred to as the Z axis.

Leads V1, V2, and V3 are referred to as the right precordial leads and V4, V5, and V6 are referred to as the left precordial leads.

Lead V1:

It is placed in the fourth intercostal space to the right of the sternum.

Lead V2:

It is placed in the fourth intercostal space to the left of the sternum.

Lead V3:

It is placed directly between leads V2 and V4.

Lead V4:

It is placed in the fifth intercostal space in the midclavicular line (even if the apex beat is displaced).

Lead V5:

It is placed horizontally with V4 in the anterior axillary line

Lead V6:

It is placed horizontally with V4 and V5 in the midaxillary line.

These leads are shown in Figure (2.12) below.

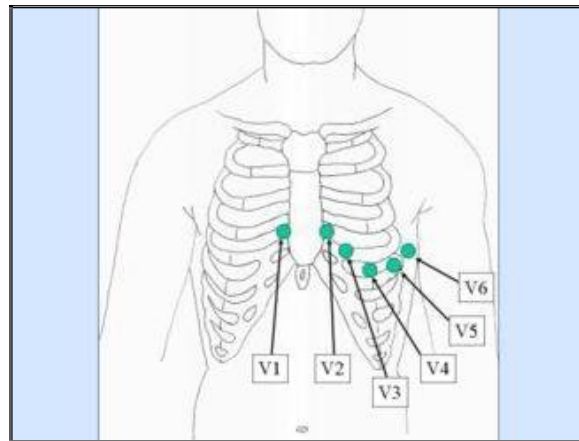

Figure (2.12): Placement of the Limb Leads⁹

3-Ground:

An additional electrode (usually green) is present in modern four-lead and twelve-lead ECGs. This is the ground lead and is placed on the right leg by convention, although in theory it can be placed anywhere on the body.

With a three-lead ECG, when one dipole is viewed, the remaining lead becomes the ground lead by default.

2.3.2 ECG Frequency:

ECG frequency ranges between 0.05 -100Hz, the electrical potential measured by ECG ranges from 1-5 mv^[3].

2.3.3 Waves and Intervals:

A typical ECG tracing of a normal heartbeat (or cardiac cycle) consists of a P wave, a QRS complex and a T wave. A small U wave is normally visible in 50 to 75% of ECGs (Figure (2.4)).

Baseline voltage of the electrocardiogram is known as the isoelectric line. Typically the isoelectric line is measured as the portion of the tracing following the T wave and preceding the next P wave.

P Wave:

During normal atrial depolarization, the main electrical vector is directed from the SA node towards the AV node, and spreads from the right atrium to the left atrium. This turns into the P wave on the ECG, which is upright in II, III, and aVF (since the general electrical activity is going toward the positive electrode in those leads), and inverted in aVR (since it is going away from the positive electrode for that lead). A P wave must be upright in leads II and aVF and inverted in lead aVR to designate a cardiac rhythm as Sinus Rhythm.

The relationship between P waves and QRS complexes helps distinguish various cardiac arrhythmias. The shape and duration of the P waves may indicate atrial enlargement.

PR Interval:

The PR interval is measured from the beginning of the P wave to the beginning of the QRS complex. It is usually 120 to 200 ms long. On an ECG tracing, this corresponds to 3 to 5 small boxes.

A PR interval of over 200 ms may indicate a first degree heart block. A short PR interval may indicate a pre-excitation syndrome via an accessory pathway that leads to early activation of the ventricles, such as seen in Wolff-Parkinson-White syndrome.

- A variable PR interval may indicate other types of heart block.
- PR segment depression may indicate atrial injury or pericarditis.
- Variable morphologies of P waves in a single ECG lead is suggestive of an ectopic pacemaker rhythm such as wandering pacemaker or multifocal atrial tachycardia

QRS Complex:

The QRS complex is the part of the ECG that corresponds to the depolarization of the ventricles. Because the ventricles contain more muscle mass than the atria, the QRS complex is larger than the P wave. In addition, because the Purkinje system coordinates the depolarization of the ventricles, the QRS complex tends to look "spiked" rather than rounded due to the increase in conduction velocity. A normal QRS complex is 0.06 to 0.10 sec (60 to 100 ms) in duration.

Not every QRS complex contains a Q wave, an R wave, and an S wave. By convention, any combination of these waves can be referred to as a QRS complex. However, correct interpretation of difficult ECGs requires exact labeling of the various waves. Some authors use lowercase and capital letters, depending on the relative size of each wave. For example, an rS complex would be positively deflected, while a RS complex would be negatively deflected. If both complexes were labeled RS, it would be impossible to appreciate this distinction without viewing the actual ECG (Figure (2.13)).

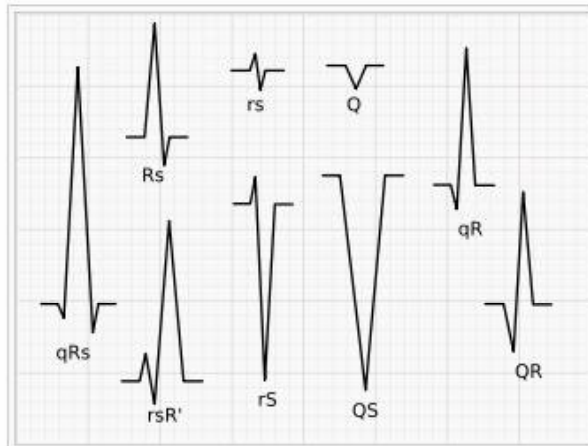

Figure (2.13): Various QRS Complexes with Nomenclature.⁹

The duration, amplitude, and morphology of the QRS complex is useful in diagnosing cardiac arrhythmias, conduction abnormalities, ventricular hypertrophy, myocardial infarction, electrolyte derangements, and other disease states.

Q waves can be normal (physiological) or pathological. Normal Q waves, when present, represent depolarization of the interventricular septum. For this reason, they are referred to as septal Q waves, and can be appreciated in the lateral leads I, aVL, V5 and V6. Greater than 0.04 sec (40 ms) in duration Q wave is considered to be abnormal, and may represent myocardial infarction.

ST Segment:

The ST segment connects the QRS complex and the T wave and has duration of 0.08 to 0.12 sec (80 to 120 ms). It starts at the J point (junction between the QRS complex and ST segment) and ends at the beginning of the T wave

It is usually difficult to determine exactly where the ST segment ends and the T wave begins, the relationship between the ST segment and T wave should be examined together.

The typical ST segment duration is usually around 0.08 sec (80 ms). It should be essentially level with the PR and TP segment.

- The normal ST segment has a slight upward concavity.
- Flat, down sloping or depressed ST segments may indicate coronary ischemia.
- ST segment elevation may indicate myocardial infarction.

T wave:

The T wave represents the repolarization (or recovery) of the ventricles. The interval from the beginning of the QRS complex to the apex of the T wave is referred to as the absolute refractory period. The last half of the T wave is referred to as the relative refractory period

In most leads, the T wave is positive. However, a negative T wave is normal in lead aVR. Lead V1 may have a positive, negative, or biphasic T wave. In addition, it is not uncommon to have an isolated negative T wave in lead III, a VL, or a VF.

Inverted (or negative) T waves can be a sign of coronary ischemia, Wellens' syndrome, left ventricular hypertrophy, or CNS disorder. Tall or "tented" symmetrical T waves may indicate hyperkalemia. Flat T waves may indicate coronary ischemia or hypokalemia.

The earliest electrocardiographic finding of acute myocardial infarction is sometimes the hyperacute T wave, which can be distinguished from hyperkalemia by the broad base and slight asymmetry.

When a conduction abnormality (e.g., bundle branch block, paced rhythm) is present, the T wave should be deflected opposite the terminal deflection of the QRS complex. This is known as appropriate T wave discordance.

QT Interval:

The QT interval is measured from the beginning of the QRS complex to the end of the T wave. A normal QT interval is usually about 0.40 seconds. The QT interval -as well as the corrected QT interval- is important in the diagnosis of long QT syndrome and short QT syndrome. The QT interval varies based on the heart rate, and various correction factors have been developed to correct the QT interval for the heart rate.

The most commonly used method for correcting the QT interval for rate is the Bazett's formula $QT_c = QT / (RR)^{1/2}$, where QT_c is the QT interval corrected for rate, and RR is the interval from the onset of one QRS complex to the onset of the next QRS complex, measured in seconds. However, this formula tends to be inaccurate, and over-corrects at high heart rates and under-corrects at low heart rates.

U Wave:

The U wave is not always seen. It is typically small, and, by definition, follows the T wave. U waves are thought to represent repolarization of the papillary muscles or Purkinje fibers. Prominent U waves are most often seen in hypokalemia, but may be present in hypercalcemia, thyrotoxicosis, or exposure to digitalis, epinephrine, and Class 1A and 3 antiarrhythmics, as well as in congenital long QT syndrome and in the setting of intracranial hemorrhage. An inverted U wave may represent myocardial ischemia or left ventricular volume overload

2.4 Theories:

This project is based upon several important theorems.

2.4.1 Bio-potential

Bio-potential: an electric potential that is measured between points in living cells, tissues and organisms, and which accompanies all biochemical processes. Also describes the transfer of information between and within cells (Figure (2.14)).

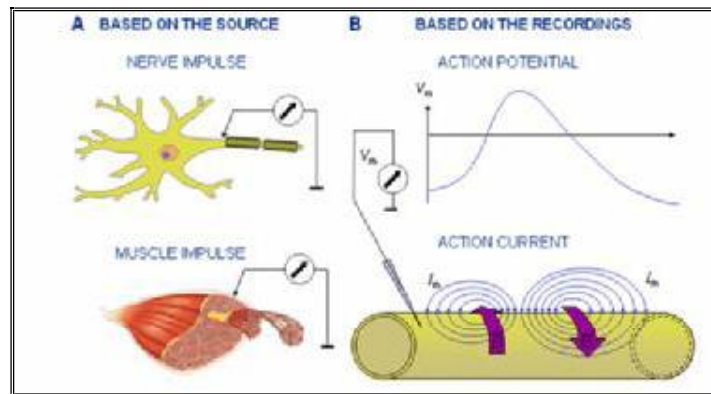

Figure (2.14): Bio-potential Measurement¹⁰

Mechanism Behind Bio-potentials:

Concentration of potassium (K^+) ions is 30-50 times higher inside the cell membrane as compared to outside. Sodium ion (Na^+) concentration is 10 times higher outside the membrane than inside. In resting state the membrane is permeable only for potassium ions (Figure (2.15)).

- Potassium flows outwards leaving an equal number of negative ions inside.
- Electrostatic attraction pulls potassium and chloride ions close to the membrane.
- Electric field directed inward form.

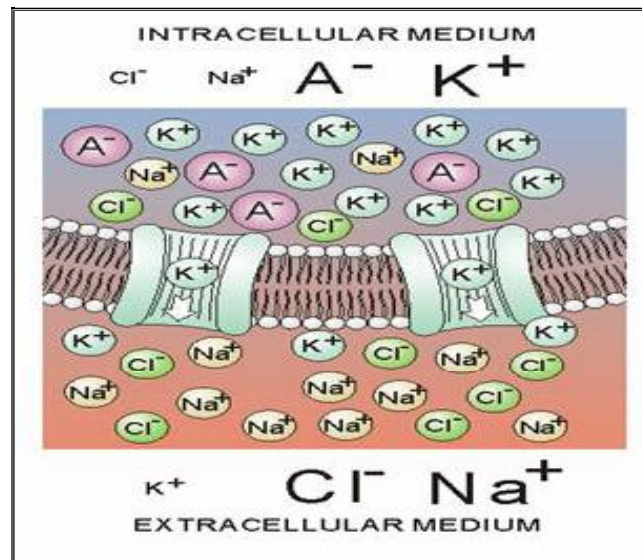

Figure (2.15): Bio-potential Mechanism¹⁰

When membrane stimulation exceeds a threshold level of about 20 mV, so called action potential occurs:

- Sodium and potassium ionic permeability of the membrane change.
- Sodium ion permeability increases very rapidly at first, allowing sodium ions to flow from outside to inside, making the inside more positive.
- The more slowly increasing potassium ion permeability allows potassium ions to flow from inside to outside, thus returning membrane potential to its resting value.
- While at rest, the Na-K pump restores the ion concentrations to their original values.

The number of ions flowing through an open channel $>10^6$ /sec. Body is an inhomogeneous volume conductor and these ion fluxes create measurable potentials on body surface

2.4.2 Electrode Theory:

An interface is necessary between the body and the electronic measuring device when recording potentials and currents in the body. Biopotential electrodes produce small voltages directly related to the changing electric field produced by a beating heart. An interface is necessary between the body and the electronic measuring device when recording potentials and currents in the body.

Biopotential electrodes produce small voltages directly related to the changing electric field produced by a beating heart. Perfectly nonpolarizable refers to the freedom of ions to pass through the electrode-electrolyte interface to be transduced into an electrical current. The electrode converts the ionic current produced by the body into a voltage, and the ECG amplifies this voltage.

The electrode-electrolyte interface is the junction where the ionic transfer occurs. A temporary current is induced in the electrode from the changing electric field of the beating heart. This current causes electrons and anions to move across the electrode-electrolyte interface in the direction opposite to the flow of the current, and for cations to migrate across this interface in the direction of the current. This temporary separation of charge produces a temporary potential.

This potential is created from a current induced from the heart and is thus directly related to the changing electric field produced by a beating heart. The ECG circuit hugely amplifies the potential, and the output gives the electric characteristics of a beating heart.

2.4.3 Sampling Theory:

Sampling theory stands for; A band limited signal to a maximum frequency (f_{\max}) Can be uniquely reconstructed from its samples being taken at a rate of sampling frequency (f_s) not less than two multiplied by f_{\max} .

2.5 Project components:

- DC voltage and current regulations.
- ECG electrodes.

- ECG modules.
- Serial cable.
- Mobile phone.
- PC.

DC Voltage and Current Regulations:

This component provides the needed voltage to the various stages of the project. It consists of:

- DC batteries.
- Regulators.
- 4 volts indicator.

ECG Electrodes:

These electrodes used to capture the bio-potential signal from the body.

ECG Module:

The processing of the electrical potential is done in this module. It consists of:

- ECG processing circuit.
- Microcontroller.

Serial Cable:

Establish the connection between ECG module and the Mobile phone.

Mobile Phone:

Receive the ECG signal and upload it via GPRS.

PC:

It contains the software for displaying and monitoring the downloaded signal.

Chapter Three

Project Design

3.1 Project Detailed Objectives:

- Design and implement the circuit that acquires the ECG signal from the patient body.
- Design and implement the microcontroller circuit where the signal process will originate.
- Design and implement the circuit that achieves the link between the microcontroller and the mobile phone using special wire.
- Construct the software for the microcontroller to do sampling, digitizing and transmitting of the processed ECG signal to mobile phone.
- Write an application for the mobile phone using J2ME language to receive the signal from the microcontroller and send it by GPRS.
- Construct the PC software that reconstruct, save and display the GPRS ECG signal.

3.2 Design Options:

The design can be achieved in many ways:

- Pick up the signal, process it, digitize and send it to the mobile phone which will upload it to GPRS and transmit it to hospital computer system.
- Use radio frequency waves to send data to the computer instead of GPRS.
- Use Bluetooth for the same purpose.
- Use micro-processor instead of PIC.
- Use GPRS module instead of mobile phone.

The first option is performed here since it is a new idea.

3.3 Realization Approach:

The project was designed and implemented between the 1st of February and the 29th of may 2008.

3.4 Suggested Block Diagram:

The following figure shows the suggested block diagram of the whole project.

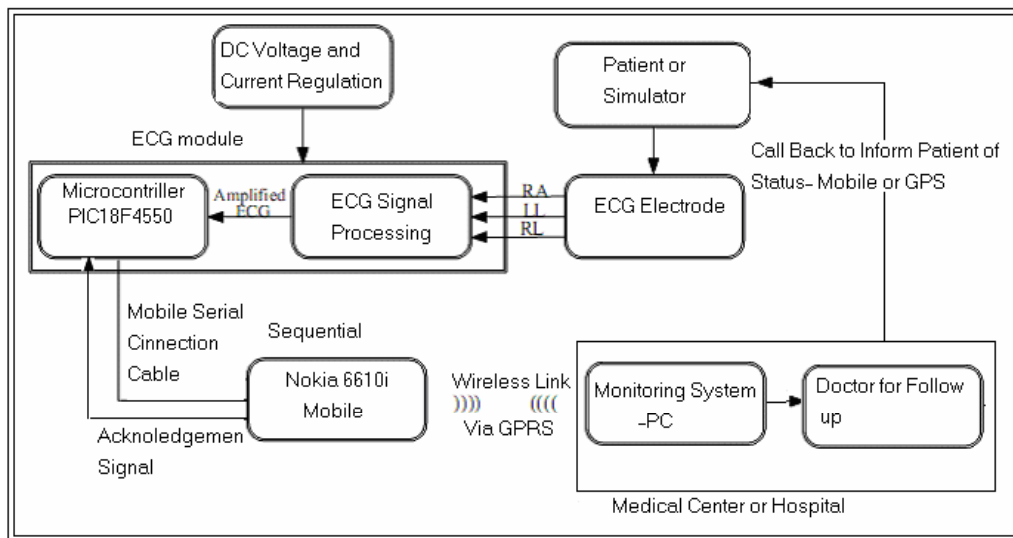

Figure (3.1): Block diagram

3.4.1 DC Voltage and Current Regulation:

Direct current (DC) batteries and regulators will be used to provide the power to the stages and modules needed for specific DC voltages (+5 volts,-5 volts). If the voltages from the batteries are more than 4 volts, a LED lights as an indicator. When they become less than 4 volts it will be turn off. alarm. Current will also be regulated to a value of 10 mA, this will help in determining the duration age of the batteries.

3.4.2 ECG Electrode:

It is a surface electrode—a transducer used to acquire the bio-potential signal from the human (patient) body, convert it to an analogue electrical signal in millivolts (mv) proportional to the bio-potential value. This signal is taken as a bio-potential difference between two points.

The most common used ECG surface electrodes is the Ag-AgCl ECG electrode, because it is non-toxic, used for long term monitoring or recording and it consists of a body of silver onto which a thin layer of silver chloride is deposited (Figure(3.2)). The silver chloride enables a free two way exchange of Ag^+ and Cl^- . It is held in place by an adhesive-coated foam rubber disk, and so it is disposable.

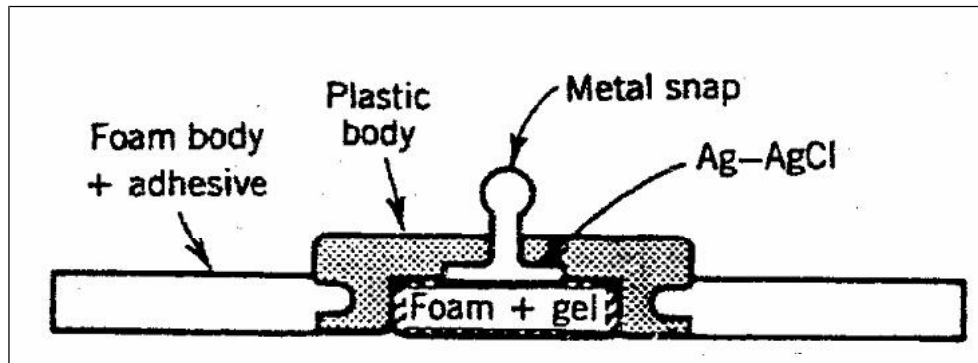

Figure (3.2): Ag-AgCl Electrode⁴

The electrode equivalent circuit is shown in the following figure:

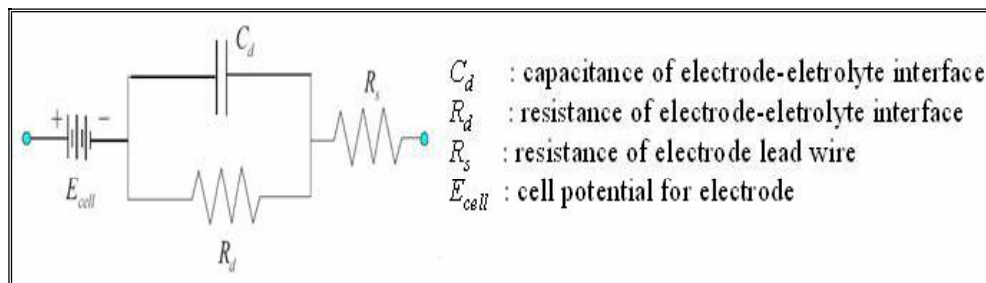

Figure (3.3): Electrode Equivalent Circuit⁴

After acquiring and converting the signal the transducer delivers the electric signal to the next stage, i.e. the EEG module.

3.4.3 ECG Module:

It consists of two stages; processing and amplifying stage, and the PIC stage. As shown in the figure below:

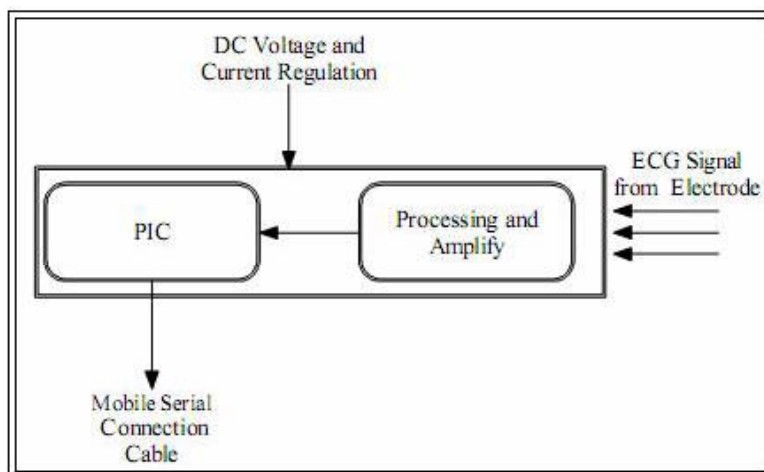

Figure (3.4): ECG Module

3.4.3.1 Processing and Amplifying:

The following sub-block shows the block diagram of the processing and amplifying circuit.

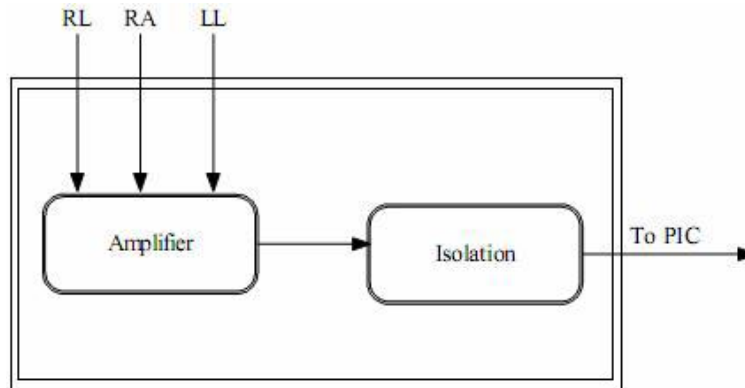

Figure (3.5): Processing & Amplifying Sub-block

The components of this circuit are:

- **Amplifier:**

It consists of instrumentation amplifier followed by a band pass filter.

Instrumentation Amplifier:

It is a differential op-amp circuit providing very high input impedances with a very high Common Mode Rejection Ratio (CMRR) and low peak to peak noise. It is used to amplify the electrical signal to a precise value determined by the gain law.

Figure (3.6) describes the schematic diagram of the instrumentation amplifier.

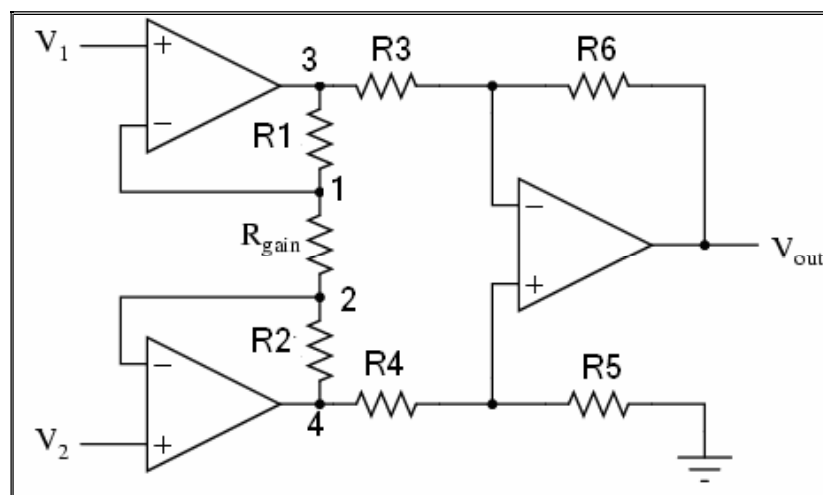

Figure (3.6): Instrumentation Amplifier¹²

It is constructed from a buffered differential amplifier stage with three new resistors linking the two buffer circuits together. The negative feedback of the upper-left op-amp causes the voltage at point 1 to be equal to V_1 . Likewise, the voltage at point 2 is held to a value equal to V_2 . This establishes a voltage drop across R_{gain} equal to the voltage difference between V_1 and V_2 . The voltage gain is given by:

$$G = (1+2*(R_2/R_{\text{gain}}))*(R_6/R_3) \quad (3.1)$$

The voltage from the input protection is delivered to V_1 and V_2 , processed then delivered to the input of the filter.

The input of the amplifier is delivered also to an essential part of the amplifier, which is the Right Leg Driven Circuit. Its output will return back to the RL for the purpose of minimizing the noise present on the body. A full description will be introduced in the next chapter.

Band Pass Filter:

It is used to allow the ECG frequency to pass and eliminate the others. Its output is delivered to the input of the isolation circuit.

Inverting Amplifier:

An inverting amplifier is used to invert the signal polarity.

- ***Isolation:***

This circuit takes its input from the filter output. It insulates the power supply and the electronic part which are in contact with patient. Its output is delivered to the PIC circuit.

3.4.3.2 PIC:

PIC is a family of Harvard architecture microcontrollers made by Technology. Basically, a microcontroller is a device which integrates a number of the components of a microprocessor system onto a single microchip and optimized to interact with the outside world through on-board interfaces, i.e. it is a little gadget that houses a

microprocessor, ROM (Read Only Memory), RAM (Random Access Memory), I/O (Input Output functions), and various other specialized circuits all in one package.

A microcontroller incorporates onto the same microchip the following:

- The CPU core.
- Memory (both ROM and RAM).
- Some parallel digital I/O.

Microcontrollers will also combine other devices such as:

- A timer module to allow the microcontroller to perform tasks for certain time periods.
- A serial I/O port to allow data to flow between the microcontroller and other devices such as a PC or another microcontroller.
- An ADC to allow the microcontroller to accept analogue input data for processing

Advantages of PIC

- Its code is extremely efficient; allows the PIC to run with typically less program memory than its competitors.
- Has low cost.
- High clock speed.

This PIC will have all the code for the various algorithms used, first it receiving the analog signal from the processing circuit (the isolation circuit), perform sampling on it, digitize it and then link it to mobile via serial cable. It is also responsible for activating alarm when battery voltage equal 5 volts; a voltage regulator is added to achieve this task.

3.4.4 Mobile Serial Connection Cable:

It consists of zener diode; as a voltage regulator to the PIC output to, and a special cable, used to achieve the connection between PIC output and the mobile phone. It has RS232 connection with the PIC. It must be compatible with the mobile type.

3.4.5 Mobile Phone:

Mobile phones are provided with GPRS service, this service is improved in the modern types. An application will be programmed to enable the mobile phone to receive the digital ECG signal from the PIC and upload it by GPRS to be delivered to the hospital PC.

GPRS:

GPRS is a packet based communication service for mobile devices that allows data to be sent and received across a mobile telephone network. It is an always-on service. The GSM network still provides voice and the GPRS network handles data, because of this voice and data can be sent and received at the same time.

There are three different classes of devices that deal with GPRS:

- *Class A:*

Class A terminals have 2 transceivers which allow them to send / receive data and voice at the same time. This class of devices takes full advantage of GPRS and GSM. You can be receiving a call and receiving data all at the same time.

- *Class B:*

Class B devices can send / receive data or voice but not both at the same time. Generally if you are using GPRS and you receive a voice call you will get an option to answer the call or carry on.

- *Class C:*

This device only allows one means of connectivity. An example would be a GPRS PCMCIA card in a laptop.

3.4.6 Hospital PC:

An algorithm is made to reverse all operations done inside the PIC, and then data base will be programmed to keep patient information.

3.5 Project Software:

The software will be made using the following languages:

3.5.1 C Language:

PIC can be programmed using different languages including Basic language , Assembly language, and C programming language. The team chose to program the PIC microcontroller using C language since they are familiar with it, and it can deal well with the complex computation the project needs.

AT Command:

Series of machine instructions used to activate features on an intelligent modem. Developed by Hayes Microcomputer Products and officially known as the Hayes Standard AT Command Set, it is used entirely or partially by most every modem manufacturer. AT is a mnemonic code for ATtention, which is the prefix that initiates each command to the modem.

3.5.2 J2ME language:

Java 2 Micro Edition is a language which brings the cross-platform functionality of the Java language to smaller devices, allowing mobile wireless devices to share applications. In this project J2ME will be used to make mobile phone applications, with a user interface.

3.5.3 LabVIEW:

It is a program used to automate testing and data gathering. It is basically a graphical programming language in which the user can set up the program to manipulate and store data.

- LabVIEW contains a comprehensive set of tools for acquiring, analyzing, displaying, and storing data, as well as tools to help you troubleshoot your code.
- In LabVIEW, you build a user interface or front panel, with controls (inputs) and indicators (outputs)
- After the user interface is built, you add code using VIs (virtual instruments) and structures to control the front panel objects.

The description of the technical design will be introduced in the next chapter.

Chapter Four

*Technical Project
Design*

4.1 Project Phases

The project will be designed in phases as follows:

- Design and construction of the system circuit.
 - Interfacing circuit.
 - Sampling and processing.
 - Mobile interfacing circuit with PIC.
- Application programs. These programmes are:
 - Mobile application program using GPRS technology.
 - PC application.

4.2 Description of Project Phases:

Phases will be designed according to the block diagram (Figure (3.1)) described in chapter three.

4.2.1 Design and Construction of the System Circuit:

4.2.1.1 Interfacing Circuit

This circuit contains:

- *Voltage and Current Regulation Circuit*

This circuit regulates the voltage delivered from each battery (9 volts 170 mAh DC) to values of +5volts and -5volts. It also regulates the output currents to 10 mA. These regulated values are delivered to the other circuits. MA723C regulator will be used for this purpose. The circuit shown in Figure (4.1) is a description of the first component of the block diagram shown in Figure (3.1).

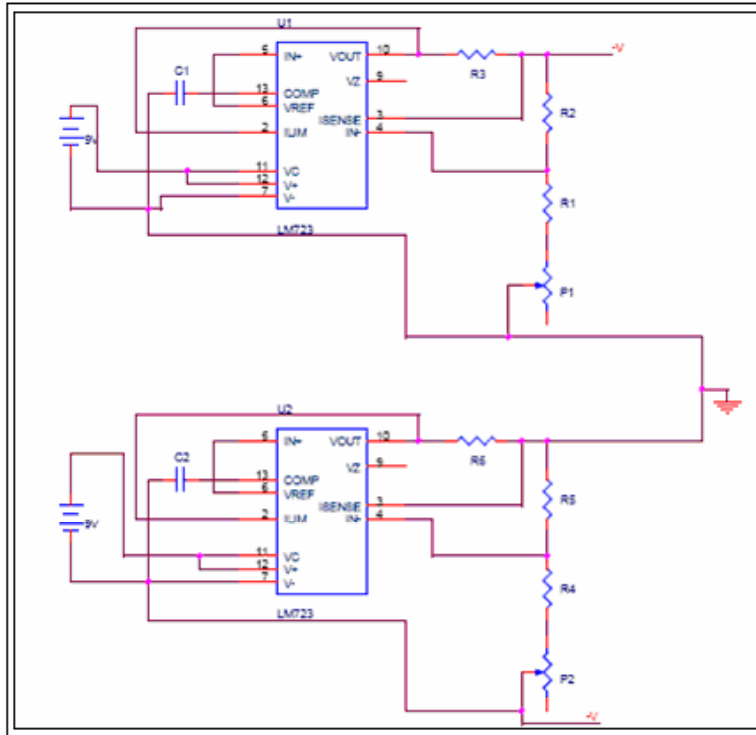

Figure (4.1): Voltage and Current Regulation Circuit¹¹

The calculations of output voltage and current values are given by:

For positive voltage (+5 volts):

$$V_{out} = V_{ref} * (R1+P1') / (R1+R2+P1') \quad (4.1)$$

$$I_{out} = V_{out} / R3 \quad (4.2)$$

Where: $V_{ref} = +7$ volts, determined in the manufacturer datasheet.

Performing calculation using these equations we will have the following values:

$$V_{out} = +5 \text{ volts}$$

$$I_{out} = 10 \text{ mA}$$

For negative voltage (-5 volts):-

$$V_{out} = V_{ref} * (R4+R5+P1') / (R4+P1') \quad (4.3)$$

$$I_{out} = V_{out} / R6 \quad (4.4)$$

Performing calculation using these equations we will have the following values:

$$V_{out} = -5 \text{ volts}$$

$$I_{out} = 10 \text{ mA}$$

A 4 volts indicator circuit is added to indicate the operation of the circuit above the 4 volts level supplied from the regulators. MAX8214 is used because it contains four precision voltage comparator which capable of monitoring undervoltage or overvoltage. This circuit is shown in Figure (3.2).

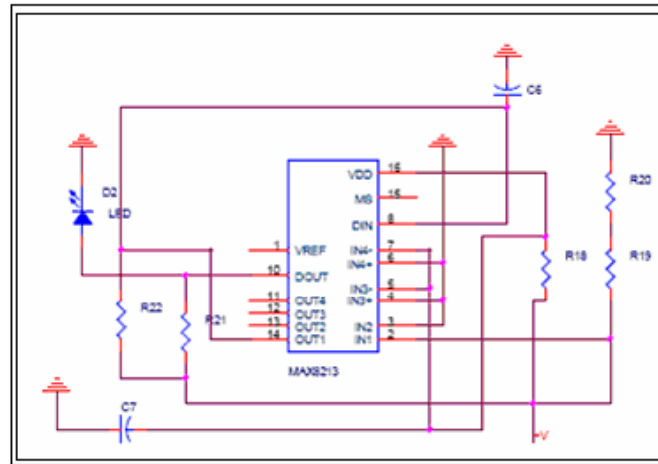

Figure (4.2): 4 volts indicator circuit¹⁹

• **ECG Electrode:**

To capture the biopotential signal from the body, Ag-AgCl electrodes are used, the amplitude will be about 1mv. Three electrodes are used for lead II connection. They will be connected to RA, LL and RL will be used as a common.

• **ECG Module:**

Referring to chapter three Figure (3.1) ECG module contains two-stages processing and amplifying circuit, and the PIC circuit.

Processing and Amplifying:

In this circuit we will process and amplify the 1mv ECG signal from the electrodes to a value of 1v, this is done by using a total gain of 1000. The ECG signal which is allowed to pass, ranges between 0.03Hz and 100Hz. According to Figure (3.5), this part is divided to:

- Amplifier.
- Isolation.

Amplifier:

As mentioned in chapter three (Figure (3.2)), the amplifier circuit contains an instrumentation amplifier and a band pass filter. It takes its input from the protection circuit mentioned before, and delivers its output to the filter.

AD620 operational amplifier IC will be used to construct this instrumentation amplifier because it satisfies several conditions: (1) Low power which makes it suitable for battery operation, (2) High accuracy, (3) Low noise, (4) Has the ability to eliminate and reject the common signal on the body and (5) It only needs one resistor to determine the gain which helps in reducing the used area. This circuit is shown in Figure (4.3).

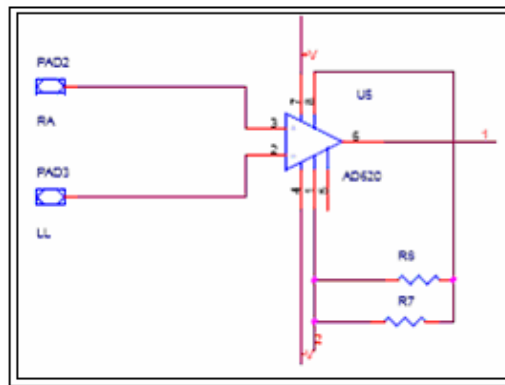

Figure (4.3): Instrumentation Amplifier Circuit

This amplifier provides a gain equal to 100, which can be determined by the following equation:

$$\text{Gain1} = 1 + (49.9\text{k}\Omega / (R6 // R7)) \quad (4.5)$$

By performing the calculation we get:

$$\text{Gain1} = 100$$

Band pass filter is designed with bandwidth of 0.03-100 Hz. As shown in Figure (4.4) below.

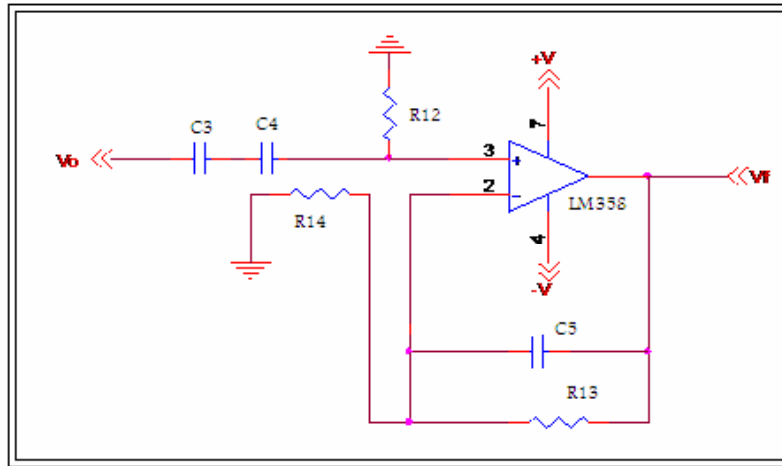

Figure (4.4): Band Pass Filter

This filter will provide a gain equal to 100 which can be calculated as:

$$\text{Gain}_2 = (R_{14} + R_{13}) / R_{13} \quad (4.6)$$

C3, C4 and R12 are related to the high pass filter and the cutoff frequency can be determined as:

$$-f_H = 1 / (2\pi * R_{12} * ((C_3 + C_4) / 2)) \quad (4.7)$$

C5, R13 are related to the low pass filter, and the cutoff frequency can be determined as:

$$-f_L = 1 / (2\pi * R_{13} * C_5) \quad (4.8)$$

The total gain for the amplifier will equal 1000 and given by:

$$\text{Gain} = (1 + (49.9\text{k}\Omega / (R_6 // R_7))) * ((R_{13} + R_{14}) / R_{13}) \quad (4.9)$$

The calculated values are:

$$. f_L = 100 \text{ Hz}$$

$$. f_H = 0.05 \text{ Hz}$$

$$\text{Gain}_1 = 100$$

$$\text{Gain}_2 = 10$$

$$\text{Gain} = 1000$$

Another essential circuit in the ECG amplifier is the driven right leg circuit.

Inverting Amplifier:

It is used with gain voltage equal to -10. This circuit is shown in Figure (4.5).

$$\text{Gain} = - R16/R15 \tag{4.10}$$

So the total gain = -10,000

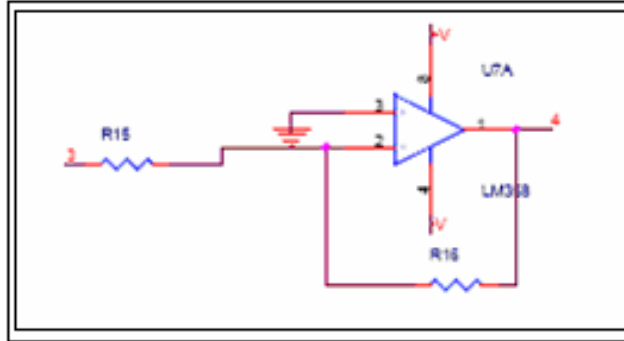

Figure (4.5): Inverting Amplifier

Driven Right Leg Circuit:

It is used in ECGs to invert common mode noise present in the circuit and feed it back to the patient to minimize the noise present on the body. Resistor values are determined through gain considerations. The driven right leg circuit is located in parallel with (R6//R7). Its use requires removal of the ground from the patient so that the driven right leg circuit may behave as a virtual ground. This circuit is shown in Figure (4.6).

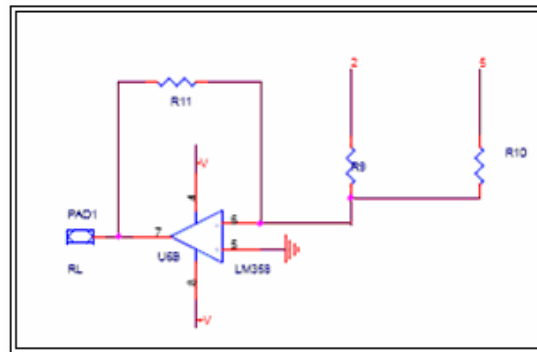

Figure (4.6): Right Leg Driven Circuit¹⁴

The resistor R9 and R10 must be equal and relatively high in value. And so the choice of their values does not affect the results. They must remain relatively high to limit current that is being fed into the circuit. High current values could be harmful to the patient. R11 must also be high to limit current fed to the patient. Since

differential gain is not important, only common mode gain will be considered. The common mode gain can be derived by first realizing that the current flowing into R11 is the negative of the current flowing into R9 resistors. In other words:

$$2 * (V_{cm}) / R11 = -(V_o) / R9 \quad (4.10)$$

Or

$$(v_o/v_{cm}) = -2*R11/R9 \quad (4.11)$$

Thus, R9 and R10 should be chosen to be less than R11 so that the common mode signal can be effectively inverted and amplified.

For the common mode gain equal to -270 the resistors are:

Isolation:

PS2506 isolator is used to achieve optical isolation. It consists of Darlington transistor, the voltage from the filter is delivered to the LED through the current limiting resistor R24, taking in consideration that the current must not exceed the LED rating current. R23 can be determined through the V_{cc} and the current through the LED as shown in Figure (4.7) where:

$$I_{LED} = V_f/R23 \quad (4.12)$$

V_f is the filter output voltage which is equal to 1 volt

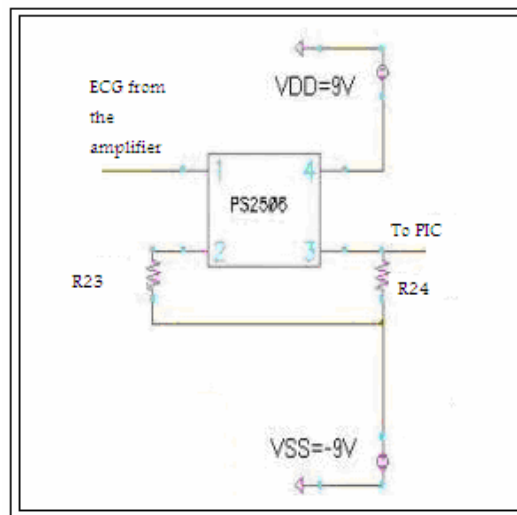

Figure (4.7): Optical Isolation Circuit¹⁹

The calculation is done so that I_{LED} equal to 10 mA since the filter output voltage will be equal to 1 volt. We can obtain that:

$$I_{LED} = I_c \quad (4.13)$$

Then

VR23 = 2 volts

Vout = 2 volt

For the circuits that use any operational amplifier except the instrumentation, we will use LM 358 since it has two amplifiers, and needs no offset which help in reducing the used area.

4.2.1.2 Sampling and Processing:

18f 4550 microcontroller will be used to perform the sampling since it has a memory size suitable for our data, an analog to digital converter inside it, and a resolution of 10 samples per second.

In the PIC circuit, part of the serial PIC connection circuit will be established by activating the USART to establish connection to the serial cable. A zener diode was added to the pin that sends data to the mobile in order to regulate the PIC output voltage with the maximum mobile input voltage. The PIC circuit and connection are shown in the figure below:

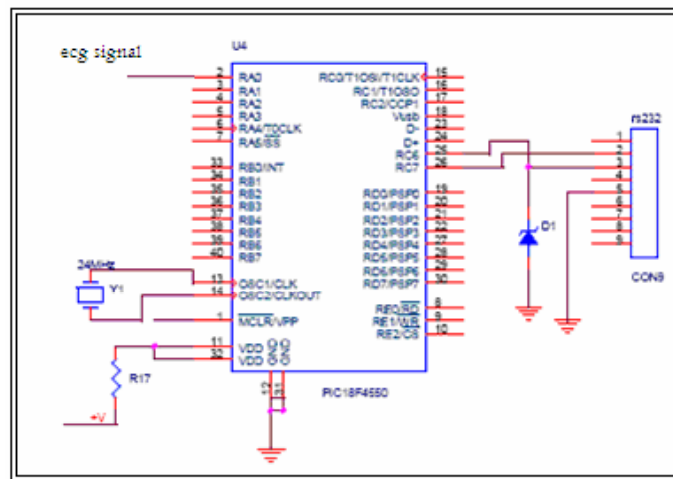

Figure (4.8): PIC Circuit

The complete schematic diagram is shown in appendix C. figure (4.9) below.

4.2.2 Signal Sampling and Processing:

After the ECG signal is delivered to the PIC, a program will be written to convert the signal from analog to digital through the ADC inside the PIC then send it to the mobile phone.

PIC Software:

The microcontroller PIC18f4550 is used as analog to digital converter (ADC) as well as initialization of universal synchronous asynchronous receiver transmitter (USART), for a serial connection to mobile phone (Nokia 6610i) and to set the mobile to work as a GPRS modem. The microcontroller also controls the sample frequency which is set to 200Hz (2* ECG signal frequency).

Analog to Digital Converter (ADC) :

To acquire data from Analog Inputs of PIC18F4550, ADCON0, ADCON1, and ADCON2 register should be configured.

The ADCON0 register, controls the operation of the A/D module. It configures the functions of the port pins. The ADCON2 register configures the A/D clock source, programmed acquisition time and justification.

A minimum wait of 2 TAD is required before the next acquisition starts. The delay between two A/D conversions dictate sampling rate of the PIC. If the A/D converter collects samples at a rate greater than the data it transfers through USART module, there will be data transmission loss. In this application, the transfer rate for the mobile phone is 9600bps (1200 bytes/sec). Since each A/D conversion generates 10 bits or 2 bytes of data for transmission, maximum sampling rate of the A/D converter for this application cannot exceed $1200/2 = 600$ Hz. We need a sample rate with 200Hz.

Since PIC18F452 has 10-bit A/D converter, the result of the PIC microcontroller A/D conversion is stored in two registers in PIC microcontroller. The lower 8 bits out of the 10 bits are stored in ADRESL (A/D Register Low) and upper two bits are stored in ADRESH (A/D Register High).

In this project:

- The analog output of the ECG Amplifier was connected to analog channel 0 of the PIC18F4550 (pin 2 (RA0)) microprocessor where it was converted to a digital signal and send to pin 25 (RC7).
- A/D Acquisition Time Select bits Frequency of A/D converter is 1/4 times of 24 MHz = 6MHz. This is not the A/D conversion rate. This is the clock A/D converter module uses to time A/D.
- A delay of (30K) instruction cycles between consecutive A/D conversions is constructed. A 24MHz clock is used to run the PIC microcontroller for this application. In PIC microcontroller, each instruction is pipelined into 4 cycles. Effectively, each instruction cycle takes $1/6 = 0.166$ microseconds. Delay introduced by 30000 instruction cycles is $30000 * 0.166$ microseconds = 4.98 milliseconds. Therefore, the effective A/D sampling rate = $1 / 4.98 = 200.8$ Hz.

Nokia 6610 Set up as GPRS modem.:

AT commands are used to make the mobile phone work as modem. After the PIC18f4550 send the AT commands to mobile, it becomes a modem and opens a GPRS connection. Figure (4.7) below shows the PIC program flowchart. The C code is attached in appendix A.

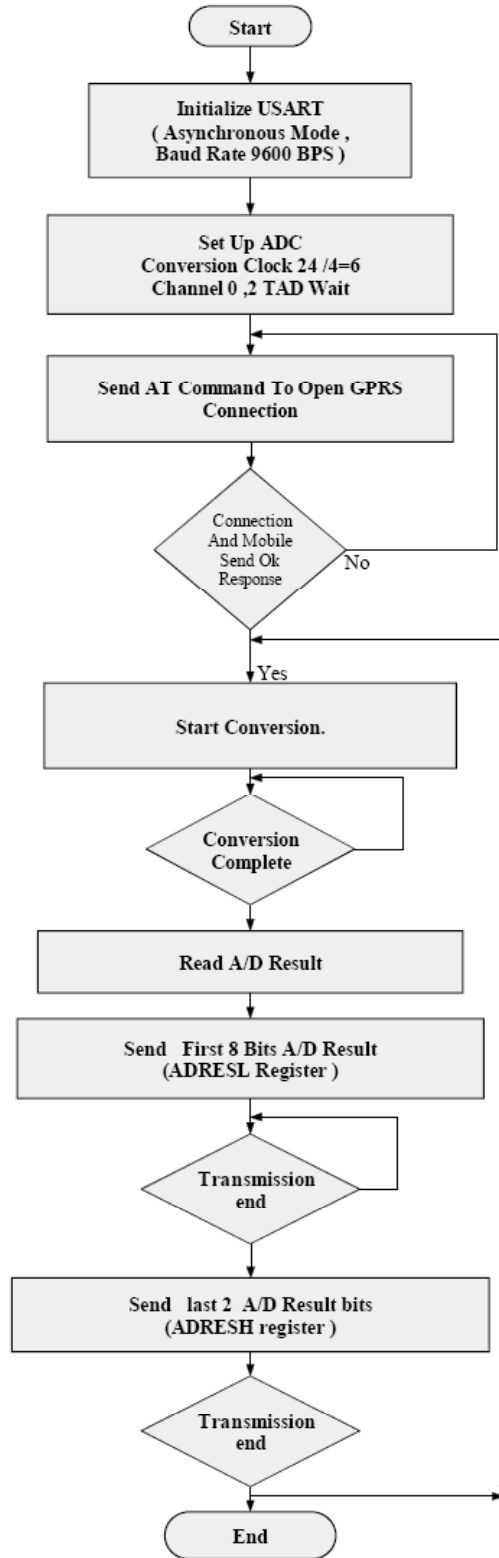

Figure (4.9): PIC Software Flowchart.

4.2.3 Mobile Interface with PIC:

Serial cable:

The serial cable used depends on the type of the mobile phone. The one that was used is fully compatible with Nokia's free application. It is suitable for Nokia 3100, 6100, 6610, 6610i, 3220. It uses Pop Port connection (plug in through bottom of phone, where the hands free connects).



Figure (4.10): 6610i serial cable¹⁵

Mobile phone:

We choose to use 6610i Nokia mobile phone since it is one of the second generation (2G) mobile phones to be compatible with 2.5G network operator (Jawwal), it has GPRS with 24-36 Kbps and it responds to the GPRS AT commands.

The connection between the mobile and the serial cable is done via the mobile pop port pinout. The port contains signals to do many tasks. The main signal of interest is FBus Rx/Tx, which performs the transmitting and receiving of data.

4.2.4 Application Programs:

There will be two application programs:

The first is a mobile application program using J2ME programming language. The application accepts the digital signal from the PIC and transfers it to a PC in the medical center using GPRS technology.

The second is a LabVIEW program that accepts the digital signal through GPRS, and converts it to analog form then displays it on the screen.

Mobile Application:

As stated in the previous chapters, J2ME programming language is used to make an application to the mobile phone. Jbuilder was the environment where this application was developed.

The application is a MIDLET that takes the digital data from the microcontroller, and then sends it to the destination PC according to the certain given IP as shown in the flowchart below in Figure (4.11).

The MIDLET consists of two main methods: RECEIVE method and SEND method.

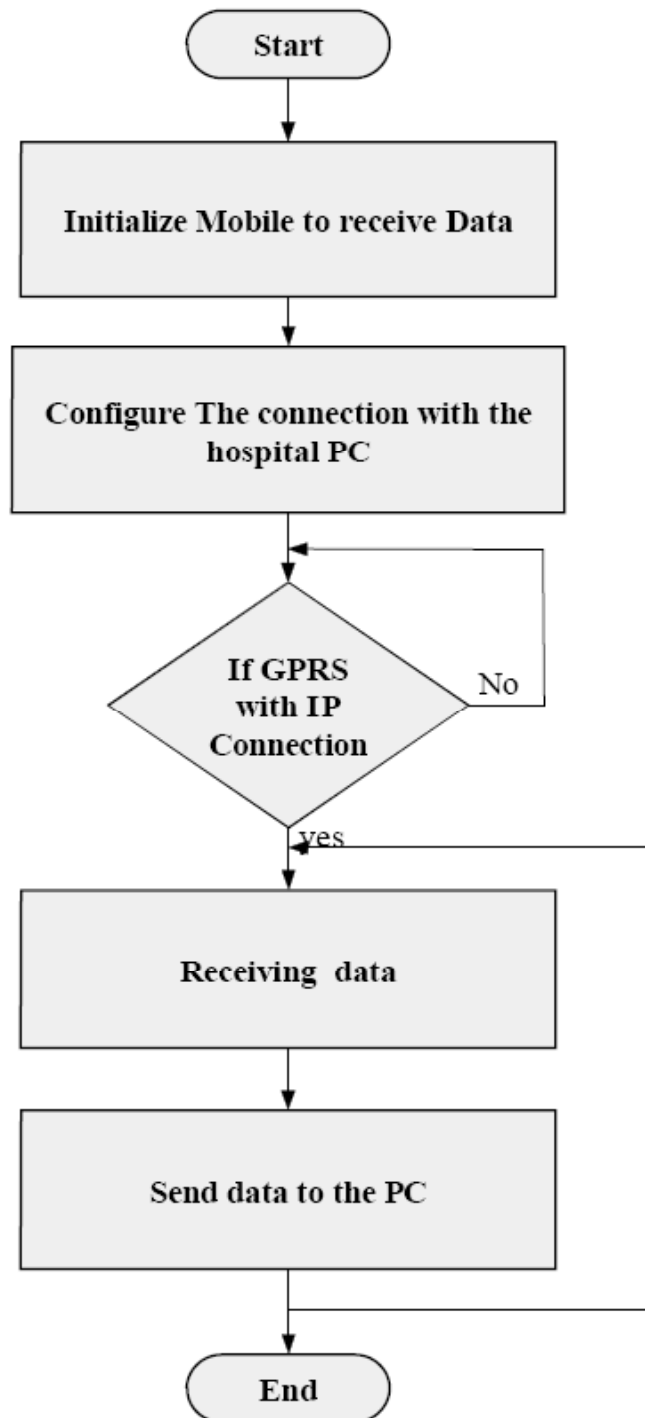

Figure (4.11): Mobile Code Flowchart

Hospital PC Software (LABVIEW Software):

The National Instruments LabVIEW 7.1 is used:

- As a server to receive the digital waveform from Nokia 6610i mobile phone (j2me code sends the data to the PC).
- To display ECG waveform after digital to analog conversion, filtering, and other necessary processing.
- To save patient ECG waveform, patient information, doctor notes, and any other needed data.

Build Server in Hospital PC Using LabVIEW :

LabVIEW has TCP/IP and UDP libraries (VIs) to support (wire /wireless) communication protocols, LabVIEW communication VIs and functions can be used to create wireless applications with reliable transmission across networks while delivering data in sequence without errors, loss, or duplication. The TCP connection automatically retransmits the datagram, which contains the data and a header that indicates the source and destination addresses, until the TCP connection receives acknowledgment of the transmission.

The PC LabVIEW code uses some of this VIs to create a listener for a TCP network connection. After the TCP network connection is accepted, the LabVIEW becomes a server that waits for any client connection (Nokia 6610 phone) and accept/transmit data.

Digital to Analog Conversion and Result Filtering:

LabVIEW has a huge number of (VIs) to deal with waveforms, signals, preceding many signal processing, and display signals.

In this project the LabVIEW code receives the transmitted data (digital ECG waveform) , making necessary processes to send digital waveforms such as converting the trings to digital waveform, invert the PIC microcontroller (analog to digital converting) to receive patient's analog ECG waveform, making necessary band bass and smoothing filtering , and at last viewing the processed signal in labview graph.

Data saving:

LabVIEW has the ability to save (write)/read any data in files at any location. It can also communicate with SQL, access, and other databases in a flexible way.

In this project, LabVIEW code saves the ECG signal, patient name, ID, address, client IP address, doctor note,etc. This labview code have also the ability to view the saved data in LabVIEW itself (in front panel) .We hope to build a full database with good user interface in future.

The LabVIEW front panel (user interface) will build in HTML page, so the processes result will display anywhere. For example the patient can see his ECG through the hospital internet webpage. Figure (4.12) illustrates the hospital PC LabVIEW Front panel (User interface). The Block diagram (graphical code) is shown in appendix C. Figure (4.13) illustrates the hospital PC LabVIEW flow chart.

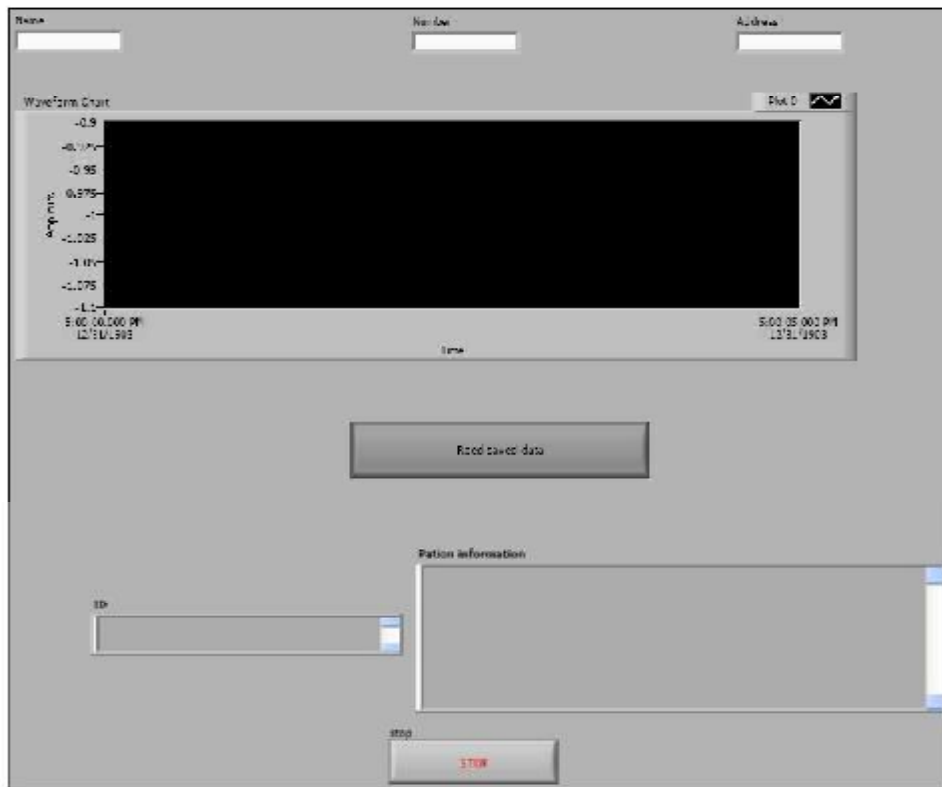

Figure (4.13): hospital PC LabVIEW Front panel

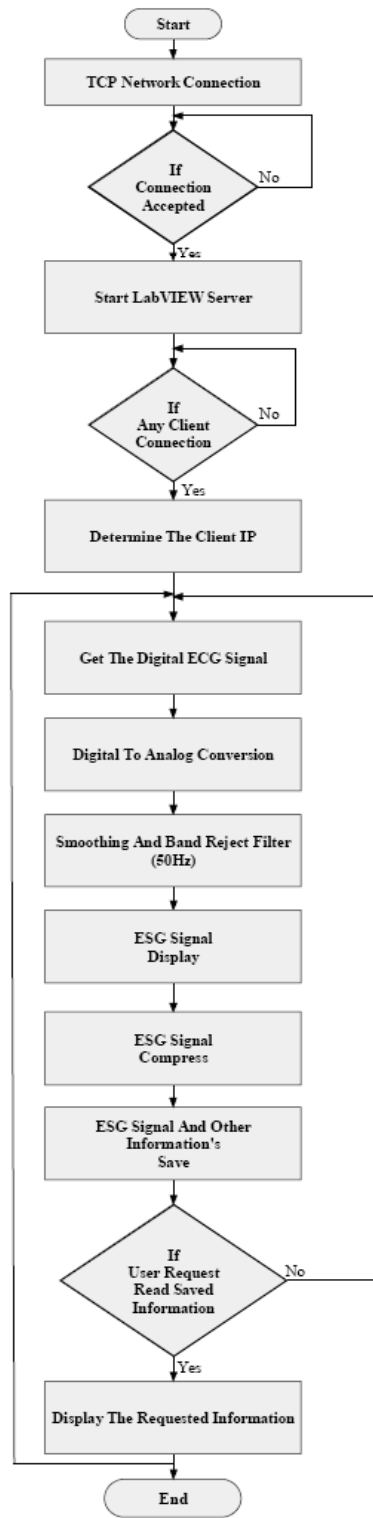

Figure (4.13): LabVIEW Flowchart

Chapter Five

*System Implementation
and Testing*

Project implementation was done step by step, each step was tested directly and results were recorded. In this chapter, results of each hardware design and software codes will be presented. An ECG Simulator was used to perform testing, and then the signal was taken from volunteers.

5.1 Hardware Testing:

Implementation and testing of each circuit was done separately, and then it was performed after integration of all circuits, combining the whole projects together. Hardware testing includes:

5.1.1 Voltage and Current Regulation Circuit Testing :

This circuit was implemented and it gave regulated +5v, -5v voltages, and a regulated current of 10 mA. These results were observed using multimeters.

5.1.2 Instrumentation Amplifier:

This circuit was built according to Figure (4.3), with 100 voltage gain. The output waveform is shown in Figure (5.1).

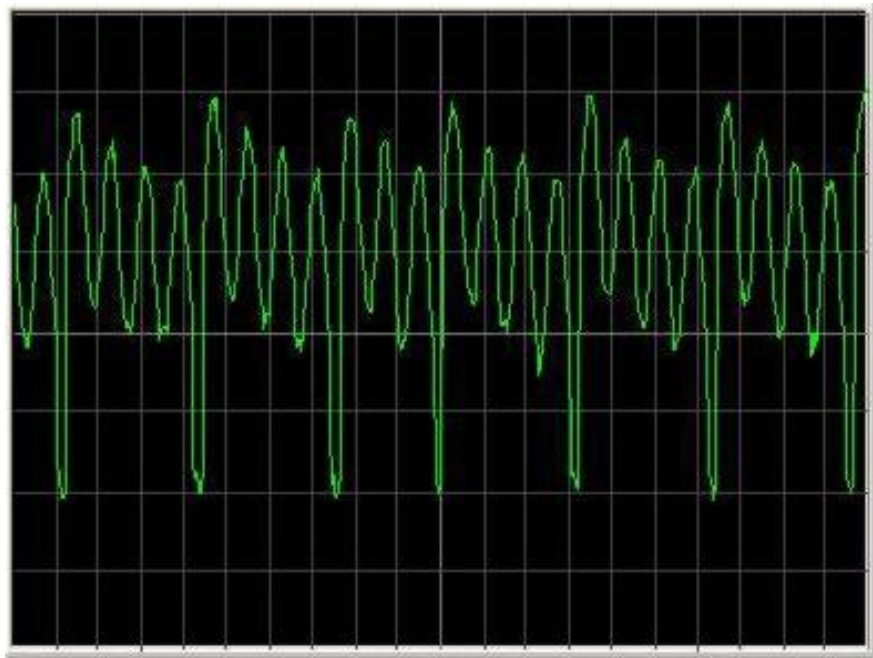

Figure (5.1): Instrumentation Amplifier Result

Voltage division= 200mv

Time division= 25ms

5.1.3 Driven Right Leg Circuit:

The output of this circuit (presented in Figure (4.4)) was taken and feedback to the right leg. This output has a sinusoidal shape as is shown in figure (5.2).

Voltage division= 50mv

Time division= 25ms

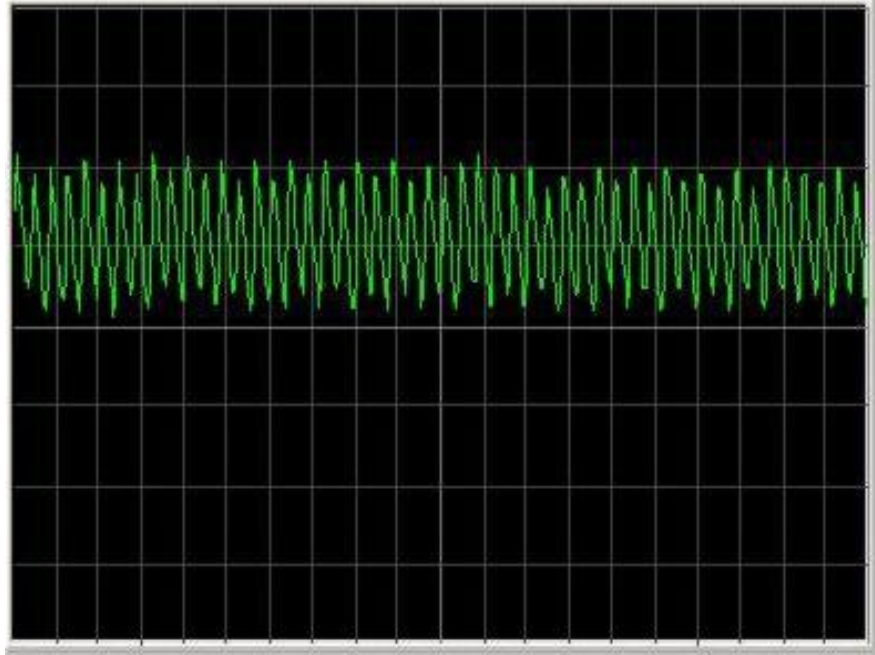

Figure (5.2): Driven Right Leg Circuit

5.1.4 Band Pass Filter Result:

This circuit was implemented as in Figure (4.4), with 10 voltage gain. The output is shown in Figure (5.3).

Voltage division= 200mv

Time division= 250ms



Figure (5.3): Band Pass Filter Result

5.1.5 Inverting Amplifier Circuit Test:

As illustrated in Figure (4.5) this circuit was implemented and the testing result is shown in Figure (5.4).

Voltage division= 200mv

Time division= 250ms

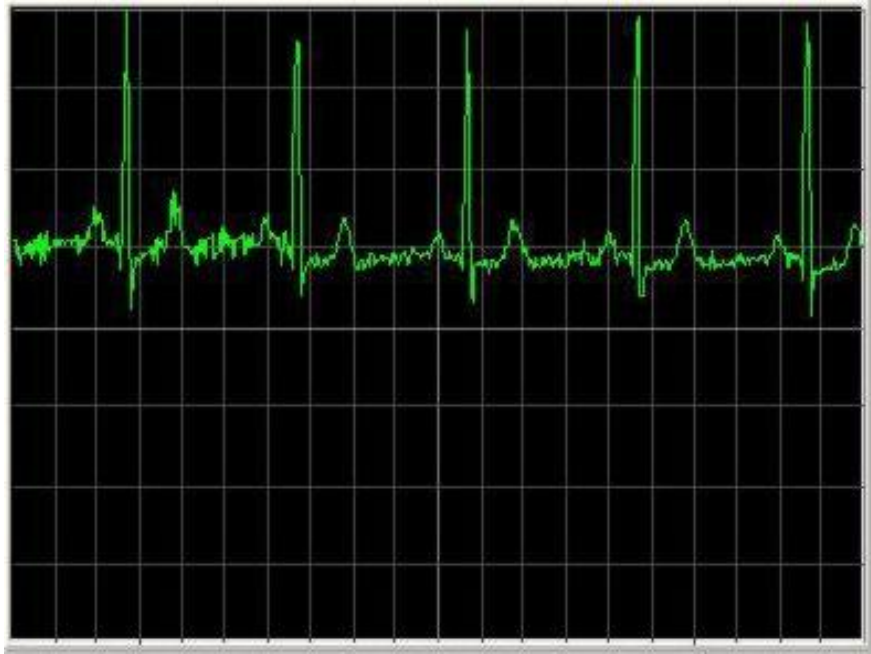

Figure (5.4): Inverting Amplifier Circuit Test

After this result, the circuit was tested using a signal from 28 years male volunteer at sitting position, the result is shown in Figure (5.5).

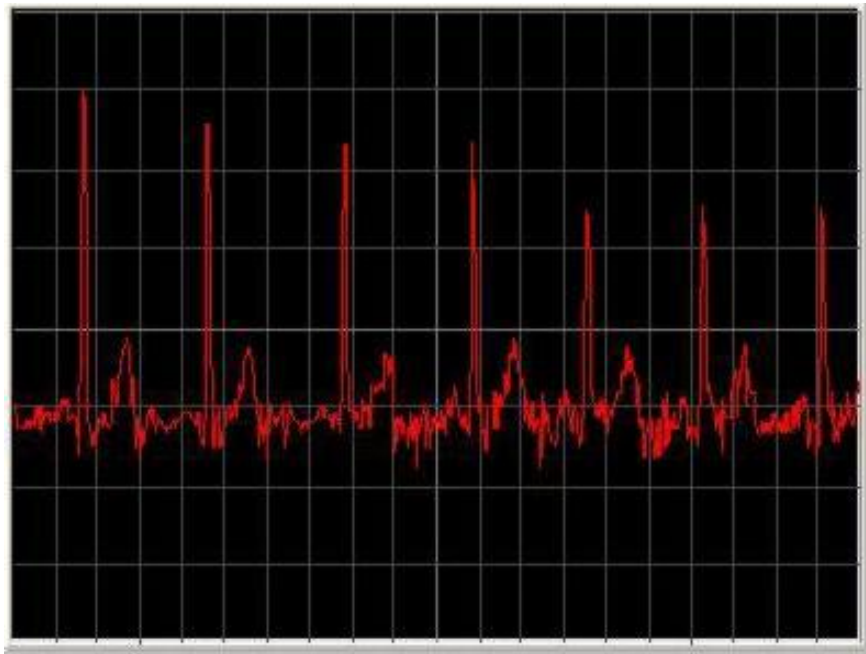

Figure (5.5): Test Result Taken from 28 Years Male Volunteer

5.1.6 PIC and Mobile Interfacing Circuit Testing:

This circuit was described in Figure (4.8) but the testing result was not tested at this point. It was tested in the software testing section.

5.2 Software Testing:

5.2.1 Analog to Digital (ADC) and USART Code:

After writing the code, it was loaded to PIC and then the whole project was assembled together. The result of ADC and USART code is shown in Figure (5.6).



Figure (5.6): Analog to Digital (ADC) and USART Code Testing

5.2.2 AT Commands Code Testing:

The first stage of this test was performed between the mobile phone and the PC, by writing the AT Commands at the hyperterminal on the computer, which allowed the mobile to work as GPRS modem and so send an email from that computer with GPRS modem to another computer connected to the internet. Figure (5.7) shows the hyper terminal page with AT commands that perform that process.

```

first - HyperTerminal
File Edit View Call Transfer Help
[Icons]

AT
OK
AT+CGMR
V 3.10
26-03-04
RM-37
(c) Nokia.

OK
AT+CGATT=1
OK
AT+CGREG?
+CGREG: 0,1

OK
AT+CGDCONT=1,"IP","WAP"
OK
AT+CGACT=1,1
OK
AT+CGACT?
+CGACT: 1,1

OK
ATD=99#
CONNECT
- )#^!|! ) |2|#)$^#)!$|X#|")&| |=| ) g)X^- )#^!|! ) |2|#)$^#)!$|X#|")&| |=|
| g)X^- )#^!|! ) |2|#)$^#)!$|X#|")&| |=| | g)X^- )#^!|! ) |2|#)$^#)!$|X#|")&|
| )=| ) g)X^- )#^!|! ) |2|#)$^#)!$|X#|")&| |=| ) g)X^- )#^!|! ) |2|#)$^#)!$|
X#|")&| |=| | g)X^- )#^!|! ) |2|#)$^#)!$|X#|")&| |=| | g)X^- )#^!|! ) |2|#)$^#)!$|
#)!$|X#|")&| |=| ) g)X^- )#^!|! ) |2|#)$^#)!$|X#|")&| |=| ) g)X^- )#^!|! ) |2|#)$^#)!$|
2|#)$^#)!$|X#|")&| |=| ) g)X^-

```

Figure (5.7): AT Command Testing at Hyperterminal

The second stage of this test was performed between mobile phone and PIC, by sending the needed AT commands as a strings using C language (through pin 25 RX) to mobile phone, receive the response (through pin 26 TX) from the mobile phone, and turn on /off five leds in port D according to the response. When the mobile works as GPRS modem, G letter can be seen in the screen of mobile.

5.2.3 LABVIEW

LABVIEW application was implemented and tested. The application front panel is shown in Figure (4.8) below, and the code is attached in appendix C.

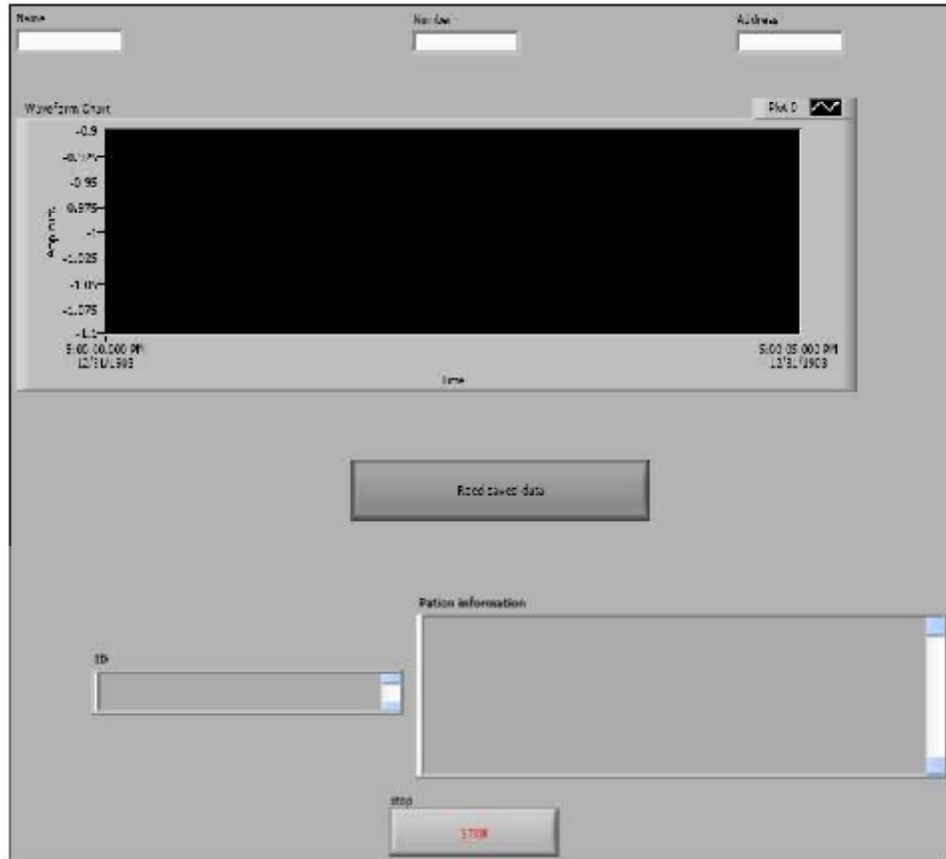

Figure (5.8): LABVIEW Front Panel

Chapter Six

Conclusions and Future Work

When starting the realization practically, the nature and the challenges of the project became more and more obvious. Many problems appeared and we managed to overcome them, however, many lessons were learned.

6.1 Conclusions:

This project was focused on the remote ECG diagnosing of patients from home using wireless technology. The system was designed, developed. Constructed and tested, and the following remarks were being outlined:

- Implementation of the ECG circuit was accomplished successfully, and so the sampling code.
- The web server and the LABVIEW application were accomplished and tested.
- The AT commands were tested between PC and the mobile phone, the test succeeded, but the test between the PIC and the mobile requires additional work.
- The J2ME mobile application was constructed. This program will be completely tested when the interface between the PIC and mobile is fully operational.
- The ideas of connecting the ECG sensor system to a mobile phone and making a C code application for digitizing and uploading data to GPRS was difficult to achieve completely. However, it was possible to transmit one signal AT command from the microcontroller to the mobile and to receive the acknowledgment from the mobile. This is a promising result for the interface. Further future work is still required.
- The idea of call feedback from the hospital to the patient on his mobile couldn't be accomplished since the cellular network has not this ability yet.
- Even with shielded housing and noise reduction circuits and algorithms, mobile radiations still affects the ECG signal seriously. This can be considered as one of the project side effects.

- Another disadvantage appears if the network clock server is not correct which means the signal will not arrive at a real time.
- The project needs more time to be finished completely, and needs more research to go over mobile effects on the signal.
- This project has been more of a research type problem and requires huge time and work.

6.2 Problems:

During the development progress several problems has occurred most of them easy to handle and what could be described as expected problems. In this chapter of the report some of the more challenging problems will be described and how they were solved.

6.2.1 Hardware Problems:

Technical

- Ground fault at the laboratories; this problem killed the ECG signal and it was solved by using batteries as power supplies.
- Low sensitivity of the available oscilloscope, this made it impossible to catch the signal. The solution was using a digital oscilloscope.

Noise Problems

- The desired electric potential that the ECG sensor is measuring is very small comparing with the noise that both the body and electrical wires absorb from the surroundings. It consists of the following sources:
- The 50- or 60-Hz interference which originates from the power cables and all electrical equipment that is powered by them.
- DC electrode offset potential
- Other noise or higher frequencies within the biophysical bandwidth come from movement artifacts that change the skin-electrode interface, muscle contraction, respiration (which may be rhythmic or sporadic)
- Electromagnetic interference (EMI) from other surrounding electronic devices that added into the input of the ECG circuit.

To reduce the noise and be able to observe the ECG signal, the following must be done:

- Employ the instrumentation amplifier AD620 in the design; where a large portion of noise can be cancelled due to its high input impedance and its high CMRR, which removes the AC line noise common to both inputs and amplifies the remaining unequal signals present on the inputs.
- In order to remove the high frequency noise and limit the output to the desired bandwidth, a high pass filter and a low pass filter are needed.
- To further reject 50-Hz and 60-Hz noise, a LabVIEW filter was designed.
- Shielded box was designed to kill the noise from surrounding devices.

6.2.2 Software Problems:

Making the mobile application was a major problem, since none of the project team had an experience in using J2ME programming language. Many books were read and many programs were reviewed in order to learn how to make the application in a way that serves the project, and that took a lot of time, effort, and attempts to do, since not only learning J2ME language what was required, but also to learn how to make the program deal with the GPRS service.

Interfacing the mobile with PIC is another problem. The interfacing was accomplished between PC and mobile phone because of the compatibility between the two devices. But it was not succeeded with PIC yet.

6.3 Future Work:

- Complete the remaining part that is not accomplished (PIC interface with mobile phone)
- Develop the c code and the hardware for all mobile phone types.
- Use another environment to send data to the hospital.
- Construct an application to avoid muscle movement effect on the ECG signal.
- Use Bluetooth instead of serial cable.
- Use wireless sensor instead of regular one.
- Save the signal and develop a database for all patients.

References:-

1-Book References:

- 1- Albert P. Malvino, Electronic Principles, Fifth Edition, McGraw – Hill Book Co., Singapore, 1993.
- 2- John R. Hampton, The ECG Made Easy, Fifth Edition, Churchill Livingstone, 1997.
- 3- Joseph D. Bronzino, Biomedical Engineering Handbook, Second Edition, CRC, 2000.
- 4- Joseph J. Carr, John M. Brown, Introduction to Biomedical Equipment Technology, Fourth Edition, Prentice Hall, New Jersey, 2001.
- 5- Robert F. Coughlin, Frederick F. Driscoll, Operational Amplifiers and Linear Integrated Circuits, 6th Edition, Pearson Prentice Hall, New Jersey, 2001.

2-Web Site References:

- 6- Lloyd. Robin, (2006). How Heart Attacks Strike. Retrieved June 1,2008, from http://www.livescience.com/health/051226_heart_attacks.html.
- 7- The Heart and the Circulatory System. Retrieved June 1, 2008, from <http://www.eurobloodsubstitutes.com/heartCircul.htm>
- 8- Electrocardiogram Mosaic. Retrieved June1, 2008, from <http://www.vanth.org/vibes/electro.html>.
- 9- (n.d) Electrocardiogram. Retrieved June 1, 2008, from <http://en.wikipedia.org/wiki/Electrocardiogram>.
- 10- (n.d) Retrieved June 1, 2008, from [http://metrology.tkk.fi/courses/S-108.4010/2006/Biopotentials.ppt#272,3,What are biopotentials](http://metrology.tkk.fi/courses/S-108.4010/2006/Biopotentials.ppt#272,3,What%20are%20biopotentials).
- 11- Retrieved June 1,2008 from http://www.datasheetcatalog.com/datasheets_pdf/L/M/7/2/LM723.
- 12- (n.d) Retrieved June 1, 2008, from <http://www.answers.com/topic/instrumentation-amplifier?cat=technology>
- 13- Shah. Raesh, Sztelle. Matthew, (1999). 345 Senior Design Laboratory MRI Cardiac Volume Analyzer. Retrieved June 1, 2008, from http://courses.ece.uiuc.edu/ece445/projects/spring99/project7_final_paper.doc
- 14- (n.d) Retrieved June 1, 2008, from http://www.shopsafe.com.au/merchants/circuitcentral_com_au/mobile_accessories_data_cables_nokia_data_cables.htm
- 15- (n.d) Retrieved June 1, 2008, from http://pinouts.ru/CellularPhones-Nokia/nokia_pop_pinout.shtml
- 16- Park. Chulsung, Chou. Pai H, Bai. Ying, Matthews. Robert, Hibbs, Andrew, (n.d). An Ultra-Wearable, Wireless, Low Power ECG Monitoring System. Retrieved June 1, 2008, from <http://www.ece.uci.edu/~chou/biocas06-ECG.pdf>.

- 17- C.Rodriguez, S. Borromeo, R. de la Prieta, J.A Hernandez, N.Malpica, (n.d).
Wireless ECG based on Bluetooth protocol: design and implementation.
Retrieved June 1, 2008, from
<http://medlab.cs.uoi.gr/itab2006/proceedings/ECG%20Preprocessing,%20Analysis%20and%20Networking/82.pdf>.
- 18- Ekstrom. Martin, (2006). Small wireless ECG with Bluetooth™ communication to a PDA. Retrieved June 1, 2008, from
<http://www.idt.mdh.se/utbildning/exjobb/files/TR0479>.
- 19- Chen. Chia-Hung, Pan. Shi-Gun, Kinget. Peter, (n.d). ECG Measurement System. Retrieved June 1, 2008, from
http://www.cisl.columbia.edu/kinget_group/student_projects/ECG%20Report/E6001%20ECG%20final%20report.htm.

Appendices

```

#include <p18f4550.h> //required for pic initialization
#include <ADC.h> //required for configuration of the ADC
#include<delays.h>
#include<portb.h>
#include <usart.h>
#include <string.h>
#define false 0
#define true 1

int i;
char COMMAND[5] = {"AT", "AT+CGATT=1", "AT+CGDCONT=1,IP,WAP",
"AT+CGACT=1,1", "ATD*99#"};
char RESPONSES[5] = {"OK", "OK", "OK", "OK", "CONNECT"};
char tmpdata; // Used in receive function
int READY = false ;
int FLAG = true ;
void receive(int j);
void send(int k);

void main()
{
TRISD=0;
TRISCbits.TRISC6 =0;
TRISCbits.TRISC7 =1;
TRISAbits.TRISA3 =0; // Set a RA0 pin for output

//configures uart with baud rate 9600 ? (4*9600)/ 2400000 1-524
OpenUSART(USART_TX_INT_OFF & USART_RX_INT_OFF & USART_SYNC_MODE $
USART_EIGHT_BIT & USART_CNTR_RX & USART_BCRH_LOW,624);

//configures and opens ADC port for reading on CFO
OpenADC(ADC_FOSC_4 & ADC_RIGHT_JUST & ADC_F_TAD,ADC_CH0 & ADC_INT_OFF &
ADC_VREFVDD & ADC_REF_14);
SetChanADC(ADC_CH0); //set ADC input to pin 2

for (i=0;i<4;i++)
{
send (i);
if(i==4) receive(i);
else receive(0);
while(FLAG)
{
if (strcmp(tmpdata,RESPONSES[i]))
{
if (i == 0)PORTDbits.RD0 = 1; // ok
if (i==1)PORTDbits.RD1= 1;
if (i==2)PORTDbits.RD2= 1;
if (i==3)PORTDbits.RD3= 1;
if (i==4)PORTDbits.RD4= 1;
}
}
}
}

```

```

    READY = 1;
        if (FRAG = false;
        )
            else

                }
            }
        }
    }
    if (READY == 1;
        )
        FRAG = true;
    }
}

while(1);

PORTA.leds.RD0 = 1; // turn on the led in pin 3 when the program start

ConvertADC(); //perform ADC conversion

while(BusyADC()); //wait for result
readADC();

pinMode(A0,OUTPUT); // transfer the AD by 8 bit to result to uart. Pin 25
while(BusyUSART() != 1); //wait for transfer finish

writeUSART(ADRES);
while(BusyUSART() != 1); //transfer the AD by 8 bit to result to uart. Pin 25

delay(1000);

}
CloseUSART();
CloseADC();
}

void receive( int j)
{
    if( DataRDyUSART( ))
        getUSART( mpdata, j); //read data ;
}

```



```
    )  
void send ( int k)  
{  
    putsUSART(COMMAND[i]);  
    while(BusyUSART());  
}
```

Appendix B

Mobile J2ME Code

```
package ecg;

import javax.microedition.midlet;*
import javax.microedition.lcdui;*
import javax.microedition.io;*
import java.io;*
import java.util;*
import java.lang.String;
import javax.microedition.rms;*

=====*/
Class ECG
=====

/*
public class ECG extends MIDlet implements CommandListener {
    Display display = null;
    List menu = null;
    private RecordStore rs = null;
    String tempo = null;
    String buffer = null;
    String url_receive = www.xyz1.com;
    String url_send = "www.xyz2.com";
    String NOME_RS="rs_ECG";
    String num_bytes=null;
    int recID_buffer=1;
    int recID_tempo=2;
    int recID_bytes=3;
    static final Command backCommand=
    new Command("Back", Command.BACK, 0);(
    static final Command mainMenuCommand=
    new Command("Main", Command.SCREEN, 1);(
    static final Command exitCommand=
    new Command("Exit", Command.STOP, 2);(
    String currentMenu = null;
    public ECG() ()
    {

    public void startApp() throws MIDletStateChangeException
    }
    cria_records();
    display = Display.getDisplay(this);(
    menu = new List("", Choice.IMPLICIT);(
    menu.append("It receives and It records", null);(
    menu.append("It shows the Buffer", null);(
    menu.append("sends", null);(
    menu.append("It receives/Records/Sends", null);(
```

```

    menu.addCommand(exitCommand;(
    menu.setCommandListener(this;(
    mainMenu;()
{
    public void pauseApp() {display = null; menu = null};
    public void destroyApp(boolean unconditional) {notifyDestroyed{;()

    public void commandAction(Command c, Displayable d(
}
    String label = c.getLabel;()
    if (label.equals("Exit")) { destroyApp(true{ ;(
    else if (label.equals("Back(("
}
    if(currentMenu.equals("menu1|| ("
    currentMenu.equals("menu2|| ("
    currentMenu.equals("menu3|| ("
    currentMenu.equals("menu4")) {mainMenu{;()
{
    else { final List down = (List)display.getCurrent;()
    Thread thrd = new Thread()
}   public void run()
}
}
    switch(down.getSelectedIndex((
}
    case 0: receive ();break;
    case 1: show_data();break;
    case 2: send();break;
    case 3: receive_send ();break;
{
{
;{   thrd.start;()
{
{

    void mainMenu()
}
    display.setCurrent(menu;(
    currentMenu = "Main;"
{

/*=====*/

    public void receive } ()

    open_rs;()

    try{ buffer=receive_measure{ ;()
    catch(Exception ex) { ex.printStackTrace{ ;()

```

```

try{ store_measure (recID_buffer, buffer){;(
catch(Exception ex) { ex.printStackTrace{ ;()

try{ store_measure(recID_tempo, tempo){;(
catch(Exception ex) { ex.printStackTrace{ ;()

try{ store_measure(recID_bytes, num_bytes{;(
catch(Exception ex) { ex.printStackTrace{ ;()

close_rs;()
currentMenu = "menu1;"
{

/*=====*/
public void show_data} ()

open_rs;()

try{ buffer=measure (recID_buffer{;(
catch(Exception ex) { ex.printStackTrace{ ;()

try{ tempo=measure (recID_tempo{;(
catch(Exception ex) { ex.printStackTrace{ ;()

try{ num_bytes=measure (recID_bytes{;(
catch(Exception ex) { ex.printStackTrace{ ;()

Form f = new Form("ECG Recorded in buffer;("
f.append("1)Measures: "+ "\r"+num_bytes+" Bytes"+ "\r\n+"
(2"   TIMESTAMP: "+ "\r"+tempo+"\r\n"+"3)Data in buffer+" :
\r" r"+buffer;(
display.setCurrent(f;(
f.addCommand(backCommand;(
f.setCommandListener(this;(
close_rs;()
currentMenu = "menu2;"
{
/*=====*/

public void send} ()

open_rs;()

try{ buffer=measure (recID_buffer{;(
catch(Exception ex) { ex.printStackTrace{ ;()

```

```

try{ tempo=measure (recID_tempo{;(
catch(Exception ex) { ex.printStackTrace{ ;()

try{ num_bytes=measure (recID_bytes{;(
catch(Exception ex) { ex.printStackTrace{ ;()

try{ send_data(buffer{;(
catch(Exception ex) { ex.printStackTrace{ ;()

close_rs;()
currentMenu = "menu3;"
{
/*=====*/
public void receive_send} ()

boolean flag = false;
int contador = 0;

open_rs;()

try{ buffer=receive_measure{ ;()
catch(Exception ex) { ex.printStackTrace{ ;()

try{ record_measure(recID_buffer, buffer{;(
catch(Exception ex) { ex.printStackTrace{ ;()

try{ record_measure(recID_tempo, tempo{;(
catch(Exception ex) { ex.printStackTrace{ ;()

try{ record_measure(recID_bytes, num_bytes{;(
catch(Exception ex) { ex.printStackTrace{ ;()

outloop:while (!flag(
}
if (contador++ > 5000000) break outloop;
try { } catch (Exception e){} (
{

try{ buffer=measure (recID_buffer{;(
catch(Exception ex) { ex.printStackTrace{ ;()
try{ tempo=measure (recID_tempo{;(
catch(Exception ex) { ex.printStackTrace{ ;()

try{ num_bytes=measure (recID_bytes{;(
catch(Exception ex) { ex.printStackTrace{ ;()

```

```

try{send_data (buffer{ :(
catch(Exception ex) { ex.printStackTrace{ :(

close_rs;()
currentMenu = "menu4;"
{

/*=====*/
private String receive_measure () throws IOException
}
HttpConnection http = null;
InputStream iStrm = null;
String str = null;
try
}

http = (HttpConnection) Connector.open(url_receive;(

http.setRequestMethod(HttpConnection.POST;(

http.setRequestProperty("Content-Type","application/x-www-form-urlencoded;("
if (http.getResponseCode() == HttpURLConnection.HTTP_OK(
}

tempo=http.getHeaderField(0;(

num_bytes = String.valueOf(http.getLength;())
System.out.println("number of bytes" + num_bytes;(

iStrm = http.openInputStream;()
int length = (int) http.getLength;()
if (length != -1(
}

byte serverData[] = new byte[length;[
iStrm.read(serverData;(
str = new String(serverData;(
{
else
}

ByteArrayOutputStream bStrm = new ByteArrayOutputStream;()
int ch;
while ((ch = iStrm.read()) != -1) bStrm.write(ch;(
str = new String(bStrm.toByteArray;()
bStrm.close;()
{
{
{

```

```

    finally
}

    if (iStrm != null) iStrm.close;()
    if (http != null) http.close;()
{
    return str;
}
/*=====*/
public void close_rs()
}
try { rs.closeRecordStore;()
catch (Exception e) {db(e.toString;()
}

/*=====*/
private void db(String str(
}
System.err.println("message of exception: " + str;(
{

/*=====*/
public void store_measure(int record, String dado) (
try}
//data output stream<- byte array output stream
ByteArrayOutputStream baos = new ByteArrayOutputStream;()
DataOutputStream dos = new DataOutputStream(baos;(
//data output stream <- given measurement

dos.writeUTF(data;(

dos.flush;()
//byte array data <- data output stream
byte[] data = baos.toByteArray;()

rs.setRecord(record, data, 0, data.length;(

Form f = new Form("ECG RECEIVED and RECORDED;(" !
// f.append("1)size of measure: "+"r"+num_bytes+" Bytes"+ "r\n"+
"2")TIMESTAMP: "+"r"+tempo+"r\n"+"3)Data Facts received and recorded:
"+"r"+buffer;(
display.setCurrent(f;(

f.addCommand(backCommand;(
f.setCommandListener(this;(
{
catch (IOException e(

```

```

    } System.out.println("Erro{ ;("
    catch (ArrayIndexOutOfBoundsException e(
} System.out.println{ ;("??")
    catch (InvalidRecordIDException e(
} System.out.println("ID doesn't exist{ ;("
    catch (RecordStoreNotOpenException e(
} System.out.println{ ;("??")
    catch (RecordStoreException e(
} System.out.println("output error{ ;("
{

/*=====*/
    private String measure (int record) {
        String leitura;"" =
        try

            int recordSize = rs.getRecordSize(record;(

            byte[] data = new byte[recordSize;[
            ByteArrayInputStream bais = new ByteArrayInputStream(data;(
//data input stream <- byte array input stream
            DataInputStream dis = new DataInputStream(bais;(

            int numBytes = rs.getRecord(record, data, 0;(

            leitura = dis.readUTF;()
            bais.reset;()
            bais.close;()
            dis.close;()
        {
            catch (IOException e(
        } System.out.println("Error{ ;("
            catch (ArrayIndexOutOfBoundsException e(
        } System.out.println{ ;("??")
            catch (InvalidRecordIDException e(
        } System.out.println("ID doesn't exist{ ;("
            catch (RecordStoreNotOpenException e(
        } System.out.println{ ;("??")
            catch (RecordStoreException e(
        } System.out.println("output error{ ;("
            return leitura;
        {

/*=====*/
    public void send_data(String buffer) throws IOException
}
    int recordID = 1;
    try
        byte[] recData = new byte[50000;[

```



```

    ByteArrayInputStream bin = new ByteArrayInputStream(recData);
//bin -> din
    DataInputStream din = new DataInputStream(bin);
    rs.getRecord(recordID, recData, 0);
    buffer = din.readUTF();
    bin.reset();
    bin.close();
    din.close();
} catch (RecordStoreException e ) { db(e.toString);()
//System.out.println(measure);
    HttpURLConnection http = null;
    OutputStream os = null;
    InputStream in = null;
    ByteArrayOutputStream baos = null;
    try}

    String header = "col"+";"+" "+"+"00000255"+"\r\n"+"
"    label"+";"+"Tempo"+";"+"Amplitude of signal"+"\r\n"+"
"    title"+";"+"Eletrocardiogram "+num_bytes+" Bytes - Coletado
em"+tempo+"\r\n;"+
//System.out.println(tempo);
    String medicaao = header+buffer;

    http = (HttpURLConnection)Connector.open(url_send);

    http.setRequestMethod(HttpURLConnection.POST);
    http.setRequestProperty("Content-Type", "application/x-www-form-
urlencoded;("

    os = http.openOutputStream();
    byte data[];
    data = ("param="+measure).getBytes();
    os.write(data);
//os.flush();

    Form f = new Form("ECG SEND OK;(!
    f.append("1) SIZE OF THE GIVEN MEASUREMENT ENVOYS:
"+"r"+num_bytes+" Bytes"+ "\r\n"+"2) TIMESTAMP: "+"r"+tempo+"\r\n"+"3)Data
sent: "+"r\n"+buffer;
    display.setCurrent(f;

    f.addCommand(backCommand);
    f.setCommandListener(this;

    in = http.openInputStream();
    byte[] b = new byte[16;[
{    finally}
    if (in != null) in.close();
    if (http != null) http.close();

```

```

{
{

/*=====*/
    public void cria_records() ()
    try
    open_rs();
    int id=1;

    if (rs.getNumRecords() == 0(
}
    while (id!=3(
}
        String nome="vazio;"
        ByteArrayOutputStream baos = new ByteArrayOutputStream();
        DataOutputStream dos = new DataOutputStream(baos;(
        dos.writeUTF(nome;(
        dos.flush();()
        byte[] data = baos.toByteArray();()
        id = rs.addRecord(data, 0, data.length;(
        baos.close();()
        dos.close();()
    {
    {
        close_rs();
    {
        catch (IOException e(
    }    System.out.println(" Error{ ;("
        catch (RecordStoreFullException e(
    }    System.out.println("Not available space exists{;(
        catch( RecordStoreNotOpenException e(
    }    System.out.println("THE Record Store this closed{;(
        catch( RecordStoreException e(
    }    System.out.println("output error{;(
    {
}
/*=====*/
    public void open_rs() ()
    try
    rs = RecordStore.openRecordStore(NOME_RS, true;(
    {
        catch (RecordStoreNotFoundException e(
    }    System.out.println("RecordStore doesn't exist;(
    {
        catch (RecordStoreException e(
    }    System.out.println("output error{ ;("
    {

```

```
/*=====*/
public void deleteRMS() {
    if (RecordStore.listRecordStores() != null)
    {
        try
        {
            RecordStore.deleteRecordStore(NOME_RS);
        }
        catch (Exception e)
        {
            db(e.toString());
        }
    }
}
```

Appendix C
LABVIEW Application Code

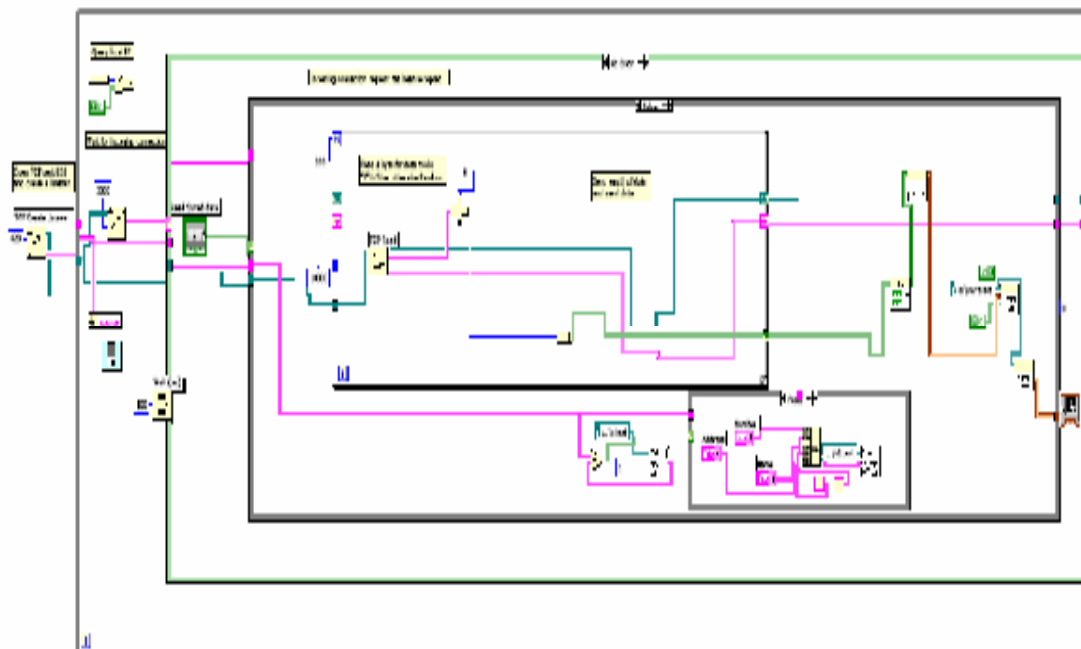

Appendix D
Schematic Diagram

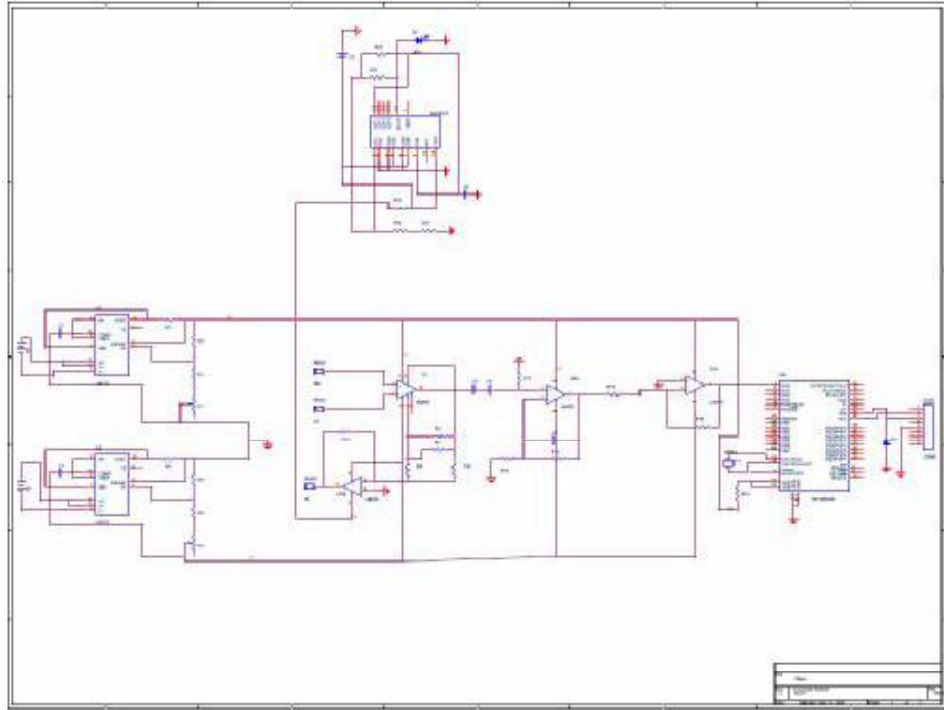

Appendix E
Components Values

<i>Component</i>	<i>Value</i>
R1	1 kΩ
R2	1 kΩ
R3	0.5KΩ
R4	1 kΩ
R5	8.4 kΩ
R6	0.005 Ω
R7	10 kΩ
R8	10 kΩ
R9	10 kΩ
R10	10 kΩ
R11	10 kΩ
R12	10 kΩ
R13	0.504 kΩ
R14	20 kΩ
R15	5400 kΩ
R16	5400 kΩ
R17	1 kΩ
R18	10kΩ
R19	10 kΩ
R20	22 kΩ
R21	1 kΩ
R22	47 kΩ
R23	130 kΩ
R24	150 kΩ
P1	100 kΩ
P2	100 kΩ
C1	10nF
C2	10nF
C3	10 nF
C4	10 nF
C7	2.2 μF
C8	2.2 μF
C9	100 nF
C10	100 nF
Zener	2.7v

Appendix F
Nokia 6610i Connector Pin



Pin Number	Pin Name	Description
1	Vin	Charger input
2	GND	Charger ground
3	ACI	Accessory Control Interface (short with pin 2 for handsfree recognition)
4	V Out	Connected to pin 3 in DKU-2 usb data cable
5	USB Vbus	Also act as USB power detection? Should be connected to USB pin 1 in usb data cable.
6	FBus Rx/USB D+	USB exists only in some models*. Should be connected to USB pin 3 in usb data cable.
7	FBus Tx/USB D-	USB exists only in some models*. Should be connected to USB pin 2 in usb data cable.
8	GND	Data GND
9	X Mic-	Audio in - Ext. Mic input negativ
10	X Mic+	Audio in - Ext. Mic input positiv
11	HS Ear L-	Audio out - Ext. Audio out - left, negativ
12	HS Ear L+	Audio out - Ext. Audio out - left, positiv
13	HS Ear R-	Audio out - Ext. audio out - right, negativ
14	HS Ear R+	Audio out - Ext. audio out - right, positiv. Pins 10-14 may be used for antenna connection.
	GND	shield GND in cavities

Appendix G
Datasheets