



**Mechanical Engineering Department**

**Air Conditioning and Refrigeration Engineering**

**Bachelor Thesis**

**Graduation Project**

**Design of VRV Air Conditioning & Mechanical  
Systems For a Villa in Halhul Town**

Project Team

**Ala'a Amleh**

**Shade Melhem**

Project Supervisor

**Eng. Mohammad Awad**

Hebron – Palestine

**June, 2013**

بِسْمِ اللَّهِ الرَّحْمَنِ الرَّحِيمِ

**Palestine Polytechnic University**

**Mechanical Engineering Department**

**Air Conditioning and Refrigeration Engineering**

**Bachelor Thesis**

**Graduation Project**

**Design of VRV Air Conditioning & Mechanical  
Systems For a Villa in Halhul Town**

Project Team

**Ala'a Amleh**

**Shade Melhem**

Project Supervisor

**Eng. Mohammad Awad**

Hebron – Palestine

**June, 2013**

Palestine Polytechnic University

(PPU)  
Hebron-Palestine

**Design of VRV Air Conditioning & Mechanical Systems For a Villa in Halhul  
Town**

Project Team

**Ala'a Amleh**

**Shade Melhem**

According to the project supervisor and the agreement of the testing committee members, this project is submitted to the department of mechanical engineering at college of engineering and technology in partial fulfillment of the requirement of the bachelor's degree (B.A).

Department Head Signature

Supervisor Signature

.....

.....

Examination Committee

.....

.....

June, 2013

## *Dedication*

*To the souls of our ancestors  
Who left with rivers of benevolence  
To our parents those who were mentors, teachers and friends  
Who were guidance with their endless giving  
To our teachers  
Who were candles, lighting our path to excellence  
To our beloved University  
Where our hearts will remain  
To all those  
We promise...  
The promise of hungry prisoners  
The promise of the blood of martyrs  
That we shall forever be loyal servants  
To our glorious Palestine*

*Ala'a Amleh*

*Shade Melhem*

## **Acknowledgment**

Our thanks go first to our advisor Eng. Mohammad Awad. His guidance and support made this work possible. His constant encouragement, intuitive wisdom, and resolute leadership were instrumental in completing this work.

And finally, our ultimate thanks go to all lectures and doctors, engineers, and laboratories' supervisors. Their efforts and their nice dealing with us improved our characters to become successful engineers in the future.

## **Abstract**

This project deals with the design of Variable Refrigerant Volume (VRV), Air Conditioning system and mechanical systems for a Villa building in Halhul town which consists of four stories .

Any building should contain mechanical services to be suitable for human use, mechanical systems include air conditioning, water supply, drainage system, rain water drainage and Fire extinguishing system.

VRV system is considered as one of the most efficient systems compared with the well known systems regarding to specifications, control, installation and cost.

This project discuss the necessary calculations for chosen Air Conditioning system, the mechanical services in it, and the distribution and design of the method used.

# Contents

## Chapter One:

INTRODUCTION	<u>Page</u>
1.1 Introduction.....	2
1.2 General Overview of the Project.....	2
1.3 Project Objectives.....	3
1.4 Project Importance.....	3
1.5 Villa Description.....	3
1.6 Project Outline.....	3
1.7 Time Planning.....	4

## Chapter Two:

HUMAN COMFORT	
2.1 Heat And Human Comfort.....	7
2.2 Heat And Temperature.....	9
2.3 ASHRAE Comfort Chart.....	9

## Chapter Three:

HEATING & COOLING LOAD CALCULATIONS	
3.1 Cooling System.....	15
3.2 Heating System.....	21
3.3 Overall Coefficient Of Heat Transfer.....	22
3.4 Sample Calculations For Cooling & Heating Load.....	27
3.5 Tables Of Results.....	34

**Chapter Four:**

**PLUMPING SYSTEMS:**

4.1 Introduction.....39

4.2 Water System.....39

4.3 Sanitary Drainage System.....47

4.4 Ventilation System.....52

4.5 Fire Extinguishing System.....53

4.6 Gas Distribution System.....54

**Chapter Five:**

**VARIABLE REFRIGERANT FLOW SYSTEM**

5.1 Introduction.....56

5.2 Refrigerant Cycle And Components .....57

5.3 Inverter Compressor.....58

5.4 Types Of VRV .....59

5.5 Features .....62

5.6 General Design Consideration.....66

5.7 Advantages And Disadvantages Of VRV.....68

**Chapter Six:**

**VRV COMPONENTS SELECTION**

6.1 Introduction.....71

6.2 Indoor Units .....71



6.3 Outdoor Unit .....	74
6.4 General Pipe Design.....	75
6.5 Limitation of VRV system.....	79
<b>REFERENCES .....</b>	<b>80</b>
<b>APPENDIX –A</b>	
Tables & Figures .....	81
<b>APPENDIX –B</b>	
Mechanical & VRV Bills Of Quantity.....	91
<b>APPENDIX –C</b>	
Project Plans	

# **Chapter One**

## **Introduction**

## **1.1 Introduction**

Human still thinking how to improve his life for better, this is the cause of spread industry and technology, and life become more easier than previous mode.

Building's technology is very important nowadays to satisfy comfort condition for occupants to make their life easier especially most of their time be inside building weather to be in homes, offices, factories, hospitals, universities, schools, etc... for this reason engineering how design any kind of building make it as possible to be suitable with occupants necessities or facilities. The most important design after architecture design for any kind of building is to supply this building by mechanical design which involves domestic water system, heating ventilation and air conditioning system (HVAC), fire extinguishing system, drainage grid system, and rain water drainage.

The air conditioning and heating has become one of the most important engineering branches that directly affect human being life. The applications of this engineering branch reach every house and organization. Air conditioning is used in many wide applications mainly in human comfort ,electronic industry and other wide applications.

The air conditioning and heating is a branch of the thermo-mechanical engineering that is specialized in the engineering methodology of obtaining a suitable environment as needed. Applying this methodology on the designs and maintenance of the air conditioning systems.

Mechanical design should satisfy all requirements inside buildings also taking into consideration the economic factor on the long term level , so in this project effort is made to complete all requirements of mechanical design in the best way and accurate calculations, to select the best equipment and machines that are suitable for Villa's use.

## **1.2 General Overview of the Project**

we will study and analyze Variable Refrigeration Volume (VRV) Air Conditioning system and mechanical services systems and apply them in a Villa building consists of

four stories in Halhul city, taking into account the design considerations applied in heating and cooling systems . Also, the components of the system will be selected .

### **1.3 Project objectives:**

- 1- The main objectives of this project is to study criteria for designing mechanical systems.
- 2- Design Variable Refrigeration Volume (VRV) Air Conditioning system for all floors.
- 3- Design domestic water and design grid of pipes to sewage and drainage system.
- 4- Design fire extinguishing system.

### **1.4 Project importance:**

- 1- The main benefit is to fulfill the graduation requirements of Palestine polytechnic university, and to be ready in working in this field after graduating.
- 2- Be familiar with all mechanical design of system installed in building to be ready for human use.

### **1.5 Villa Description**

The Villa consists of four stories; ground, first, second, and third floor. And the total area of Villa is about (1192m<sup>2</sup>), the Villa contains bedrooms, living rooms, guest rooms, bathrooms, offices, and stores.

### **1.6 Project Outline**

The project is composed of six chapters as follows:-

#### **Chapter One:- Introduction**

This chapter includes an overview, main objectives, Villa description, methodology, budget, time table, and the project outline.

## **Chapter Two: Human Comfort**

This chapter includes the comfort conditions inside building, psychometric characteristics, then heat transfer through building and how heat is transmitted, finally inside and outside conditions are applied in our project.

## **Chapter Three: Heating & Cooling Load Calculations**

Includes explain about heating system and load calculation procedures of it , and the source of heat loss inside building, also talks about cooling load and how to calculate it from all sources of heat gain inside Villa.

## **Chapter Four: Plumping and mechanical systems**

This chapter talk about plumping system, water distribution system ( cold and hot water) and how potable water shall be distributed inside Villa by using suitable pipes and how the pipes could be designed, also components of drainage system and the procedures to design network drainage pipes, manhole design and about septic tank calculations. In addition to many mechanical systems created to facilitate the life style such as ventilation, fire extinguishing system, and domestic gas distribution system.

## **Chapter Five: Variable Refrigerant Flow System (VRV)**

This chapter includes a detailed review ,study and analysis of (VRV) system.

## **Chapter Six: VRV Components Selection**

This will include selection of all VRV system equipments that are needed to be installed inside the building depending on accurate calculation.

### **1.7 Time Planning**

The project plan follows the following time schedule, which includes the related task of the project and system analysis.

#### **1.7.1 The first semester time plan**

**Table (1.1) The first semester time plan**

Task\week	1	2	3	4	5	6	7	8	9	10	11	12	13	14	15	16
Project selection	■	■	■													
Information Gathering				■	■											
Writing introduction & human comfort						■	■									
Load calculation								■	■	■	■					
VRV system												■	■			
Printing final copy														■	■	

**1.7.2 The second semester time plan**

**Table (1.2) The second semester time plan**

Task\week	1	2	3	4	5	6	7	8	9	10	11	12	13	14	15	16
Information & data gathering	■															
Plumping systems		■	■	■												
Design & selection of VRV system					■	■	■									
Drawing planes & selection of equipments								■	■	■	■					
Making bill of quantity (BOQ)											■	■	■			
Printing final copy															■	■

# **Chapter two**

## **Human Comfort**

## **2.1 Heat and Human Comfort**

The HVAC indoor design requirements are chosen to meet human body needs under the specific occupancy conditions of a space. In order to understand the basis of these conditions it is first necessary at the outset to understand the fundamentals of body temperature control and the physical principle of heat transfer.

### **2.1.1 Body Temperature Control**

Human beings are constant-temperature (warm-blooded) creatures with a normal deep body temperature of 37 °C . We emphasize that this is an internal temperature because the external (skin) temperature can vary from a low of about 4.4 °C to a high of about 41.1 °C . This external temperature can be maintained for a limited time without physiological damage. Indeed, the wide variation in skin temperature is one of the techniques used by body's highly sophisticated automatic temperature control system in order to regulate heat transfer to the environment.

The amount of heat generated by the body depends on the type of personal activity, this heat or energy is produced by metabolizing the food we eat there for referred to as the body metabolic rate. The entire process is known as metabolism. The body is only about 20% efficient in converting food to muscular energy, the other 80% is converted to heat that must be disposed of continuously to avoid overheating the body. The body disposes of heat by one or more of the four physical processes for heat transfer and exchange: evaporation, radiation, convection, and conduction. And there is previous plan about each one:

#### **1) Evaporation**

This mode of cooling accounts for the removal of about 25% of body heat. There are two mechanics of evaporation and a balancing reaction to respond to the changing environment:

- Respiration: This accounts for the difference in the humidity of the air during inhale and exhale. More humidity is carried by exhausting air than by the inhaling air.
- Insensible skin moisture: The skin is always covered by a thin film of sweat that evaporates into the surrounding air, thus cooling the skin behind it. It terms insensible because it's a continuous process.



## 2) **Radiation:**

As the body or the clothing over it is at a higher temperature than the environment, heat loss from the body to the environment takes place continuously. The heat loss from the body by this mode accounts for about 45% of total heat loss of the body

## 3) **Convection:**

Heat is removed from the body by the air movement around the body; the air movement is due to heating the air in contact with the body, or by the wind in the environment. The heat loss by convection accounts to about 30% of the total heat loss by the body.

## 4) **Conduction:**

This heat loss results from direct contact of the body with objects in its surrounding. However, as far as normal human beings are considered the heat loss by this mode is negligible.

### **2.1.2 Body Heat Balance**

The normal body temperature is 37.2 °C which is in most cases higher than the ambient temperature thus heat is continuously transferred from humans to their ambient air by virtue of this difference in temperature. For body thermal equilibrium to be maintained heat must be produced within the body in amount equal to the heat loss by the body. Metabolism is the biological process by which body cells generate heat from consumed food. The efficiency of this transformation is about 20%, the amount of heat produced by human body depends on the number of cells of the body. Thus large animals produce more heat than can be dissipated through their limited skin area. Therefore they need to live near water to dip in and cool their bodies.

The metabolic rate (M) varies from one to another depending on age, sex, and type of activities, where the values of metabolic rate takes from special tables according to the type of activity, and could be calculated by using this equation:

$$M-P=E+R+C+S \quad (2.1)$$

Where, P is the power output of the individual, E is the rate of heat dissipated by evaporation from the body, R is the rate of heat dissipated by radiation from the body, C is the rate of heat dissipated by convection, and S is stored or the residual thermal power.

## **2.2 Heat and Temperature**

Heat is form of energy. Temperature is simply an arbitrary scale invented in order to indicate the intensity of heat energy contained in an object. Many units are used to scale temperature such as, Fahrenheit and Celsius. Also the units of heat energy vary according to system used for example Watt (W) or British Thermal Unit (BTU).

### **2.2.1 Sensible Heat and Latent Heat**

Sensible heat is the heat which causes a change in temperature when it is added or removed. Latent heat is that which causes a change of state or phase in the substance while the temperature remains constant.

## **2.3 ASHRAE comfort chart:**

The ASHRAE is an abbreviation for the American Society of Heating Refrigeration and Air-conditioning Engineers. There is no rigid rule that indicates the best atmospheric condition for comfort for all individuals. This is because human comfort is affected by several factors such as health, age, activity, clothing, sex, food, etc.

Comfort condition are obtained as result of tests for which people are subjected to air at various combinations of temperature and relative humidities. The result of such test indicate that a person will feel just about as cool at 24 °C and 60% RH as at 26 °C and 30% RH. Studies conducted by ASHRAE with relative humidity between (30%-70%) indicated that 98% of people feel comfort when the temperature and relative humidity combination fall in comfort zones such as that indicated in figure (2.1) below.

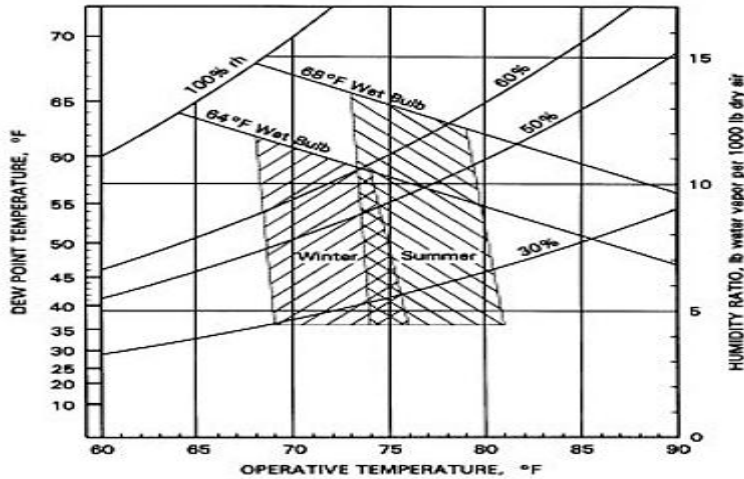

Figure (2.1) comfort zones of operative temperature and relative humidity

### 2.3.1 Factors Affecting Human Comfort:

#### 1. Dry air:

The dry air is a complex mixture of several Gases such as nitrogen ,oxygen, carbon dioxide and other gases such as argon ,carbon monoxide and neon .It does not contain water vapor .the presence of nitrogen in the air represents about 78%by volume while the oxygen occupies about 21% by volume .the other gases represent less than 1%.

#### 2. Moisture air:

The moisture air is mechanical mixture of dry air and water vapor .thus , when moisture air is cooled ,it losses moisture due to the condensation of the water vapor in the air.

#### 3. Humidity :

The moisture content of the air is referred to as its humidity .This moisture content can be expressed in terms of volume ,masses and moles of pressure .

#### 4. Saturation :

Saturation indicates the maximum amount of water vapor that can exist in one cubic meter of air at a given a temperature .It does not depend on the mass and pressure of the air which may simultaneously exist in the same space.

### *5. Partial Pressure:*

Low pressure air-water vapor mixture follows closely the Gibbs-Dalton law of partial pressure. This law states that the total pressure of a mixture of gasses is the sum of the partial pressure of each of its constituent gas occupies the entire volume and has the same temperature of the mixture.

### *6. Dry Bulb Temperature:*

Dry bulb temperature is the air temperature that is measured by an accurate thermometer or thermocouple where the measuring instrument is shielded to reduce the effect of direct radiation.

### *7. Wet Bulb Temperature:*

The air temperature measured, using a wetted thermometer bulb, is known as wet bulb temperature. When unsaturated air passes over a wet thermometer bulb, water evaporates from the wetted bulb. Vaporizing latent heat is absorbed by the vaporizing water and thus causes the temperature bulb to fall. The instrument used to measure the wet bulb temperature is called psychrometer.

### *8. Dew-Point Temperature:*

The dew-point temperature is the saturation temperature corresponding to the partial pressure of the water vapor in the surrounding air. When the dew-point temperature is reached, condensation starts as the moist cooled at constant pressure. Further cooling results in more condensation of water vapor. Moreover, at the dew-point temperature or below, the air is said to be saturated because the air is mixed with the maximum possible amount of water vapor.

### *9. Humidity Ratio:*

The humidity ratio  $w$ , is defined as the mass of water vapor associated with unit mass of dry air.

### *10. Relative Humidity:*

The relative humidity, is the ratio of actual partial pressure of the water vapor in the air  $p_v$ , partial pressure of the water vapor.

### 2.3.2 Thermal comfort criteria for inside design condition:

The inside design conditions refer to temperature, humidity, air speed and quality of inside air that will induce comfort to occupants of the space at minimum energy consumption.

There are several factor that control the selection of the inside design conditions and expenditure of energy to maintain those conditions:

- 1-The outside design conditions.
- 2-The period occupancy of the conditioned space.
- 3-The level of activity of occupants in the conditioned space.
- 4-The type of building construction and its use.

Usually the range of temperature difference between inside and outside is from 4 to 11 °C . Relative humidity range for the conditioned space varies from 30% to 60%. Air velocity inside conditioned space it is desirable to keep it within the range of 0.1 to 0.35 m/s for comfort. A dry environment will be felt when the relative humidity above 60%.

When the inside design condition for a certain application are selected cost and energy (fuel, electricity, etc) should be taken into consideration.

#### 2.3.2.1 Comfort conditions inside Villa:

All calculations (heating and cooling loads) will be made according to specified values for inside conditions of Villa design in table (2.1) refer to dry bulb temperature and relative humidity in both summer and winter seasons.

**Table (2.1) Recommended inside design conditions for summer and winter:**

Season	Dry bulb temperature, $T_{in}$ (°C)	R.H (%)
Summer	22	55
Winter	22	55

### 2.3.3 Outside design condition:

The outside conditions due to dry bulb temperature, relative humidity, and wind speed are tabulated in below table (2.2), according to Palestinian code for Hebron city.

**Table (2.2) Values for outside design condition for Halhul town:**

<b>Season</b>	<b>Dry bulb temperature, <math>T_{out}</math> (°C)</b>	<b>R.H (%)</b>	<b>wind speed (m/s)</b>
<b>Summer</b>	31	49	1.4
<b>Winter</b>	3	73	1.4

# **Chapter Three**

## **Heating & Cooling Load Calculations**

### 3.1 Cooling System

The rate at which heat energy must be removed from a space in order to maintain a given inside design condition is called the cooling load.

The cooling load is expressed in units of watt (Joule per second) or in kilowatts (kW) or in tons refrigeration (T.R) where 1 T.R. = 3.517 kW. Sometimes, the metric units of kilocalorie per hour (kcal/h) are used where 1 W = 0.8601 kcal/h.

The heat gain of a given space or its cooling load can be removed by mean of cooling equipment which supply cold air o the space in adequate amounts to maintain a given inside design temperature. The heat gain is the rate at which energy is transferred to or generated within the space. The heat gains may be external or internal gains.

Buildings and building spaces gain and loose sensible heat as well as latent heat. Both sensible heat and latent heats are produced inside the spaces by occupants, lights and equipment. Sensible heat causes temperatures to raise while latent heat does not cause temperature rise but it changes the condition of the air in the space such that it results in a higher humidity.

The cooling load of a given space consists of the following heat gains :

- 1- Heat gains that are transmitted through shaded building structures such as walls, floors and ceilings and that adjacent to unconditioned space.
- 2- Heat gains due to solar effects which include:
  - a- Solar radiation transmitted through the glass into the air conditioned space and absorbed by inside space surfaces and furniture.
  - b- Solar radiation absorbed by walls, glass windows, glass doors, and roofs that are exposed to solar radiation.
- 3- Sensible and latent heat gains brought into the space as a result of infiltration of air through windows and doors.
- 4- Sensible heat produced in the space by lights, appliances, motors and other miscellaneous heat gains.
- 5- Latent heat produced from cooking, hot baths, or any other moisture producing equipment.



## 6- Sensible and latent heat gains due to occupants.

### 3.1.1 Heat Gain Through Sunlit Walls And Roofs:

Direct and diffused solar radiation that is absorbed by walls and roof result in rising the temperature of these surface .amount of radiation absorbed by walls and roofs depends upon time of the day, building orientation, types of wall construction and presence of shading.

The calculation of this type of heat gain be obtain by using the following relation for heat transmission through walls.

$$Q = U * A * CLTD_{corr} \quad (3.1)$$

But we find the magnitude of heat transfer throw inside walls is relation by :

$$Q = U * A * \Delta T \quad (3.2)$$

Where:

CLTD<sub>corr</sub> : cooling load temperatures difference for sunlit roofs and walls since:

$$CLTD_{corr} = (CLTD + LM)k + (25 - T_i) + (T_{o,m} - 29.4)f \quad (3.3)$$

LM: is latitude correction factor .

K: is color adjustment factor where it equal 1 then dark colored roof or 0.5 then it permanently light colored roofs.

T<sub>i</sub>: indoor design temperature =22 °C

T<sub>o,m</sub>: outdoor mean temperature.

$$T_{o,m} = T_o - \frac{DR}{2} \quad (3.4)$$

T<sub>o</sub>: outdoor design temperature =37 °C

DR: the daily rang temperature =( T<sub>ave. max</sub> - T<sub>ave. min</sub>) in July =(37-17)= 20 °C

$$T_{o, m} = 37 - \frac{20}{2} = 27 \text{ }^{\circ}\text{C}$$

$f_r$  is attic or roof fan factor which is equal 1 if there is no roof fan , and equal 0.75 if there is an attic or roof fan .

$Q$  : the rate of heat transferred in watts (W).

$A$  : the inside surface area of the wall ( $\text{m}^2$ ).

$U$  : the overall coefficient of heat transmission in watts per square meter per callous.

$\Delta T$  : The temperature differential across the wall in callous.

### 3.1.2 Heat Transmitted through glass:

Solar radiation which falls on glass has three component which are:

- 1- Transmitted component: it represents the largest component, which is transmitted directly into the interior of the building or the space. This component represents about 42% to 87% of incident solar radiation, depending on the glass transmissibility value.
- 2- Absorbed component: this component is absorbed by the glass itself and raises its temperature. About 5 to 50% of solar radiation it absorbed by the glass, depending on the absorptive value of the glass.
- 3- Reflected component: this component is reflected by the glass to the outside of the building. About 8% of the solar energy is reflected back by the glass.

The amount of solar radiation that can be transmitted through glass depends upon the following factors:

- 1- Type of glass (single, double or insulation glass) and availability of inside shading.
- 2- Hour of the day, day of the month, and month of the year.
- 3- Orientation of glass area. (North, northeast, east orientation, etc).
- 4- Solar radiation intensity and solar incident angle.
- 5- Latitude angle of the location.

### 3.1.3 Transmission Heat Gain:

Heat gain due to solar transmission through glass windows and glass doors is estimate by using equation:

$$Q = A(\text{SHG})(\text{SC})(\text{CLF}) \quad (3.5)$$

Where is:

(SHG): is factor represents the amount of solar energy that would be received by floor, furniture and inside walls of the room.

(SC): shading coefficient represented at finding the shading at windows.

(CLF): Cooling load factor represent effect of the internal walls floor, and furniture on the instantaneous cooling load.

In our project we choose the windows is clear insulation glass (glass wool) with thickness = 4mm with interior shading type of interior shading venetian blinds light then (shading coefficient ) SC = 0.51

### 3.1.4 Convection Heat Gain:

The convicted cooling load by the glass is calculated from the equation:

$$Q = A * U * (\text{CLTD})_{\text{corr}} \quad (3.6)$$

Where (CLTD)<sub>corr</sub>. is calculated by using equation (3.3).

### 3.1.5 Door Gain Load:

#### 1- External doors:

Heat gain through external doors can be calculated by equation (3.1):

$$Q = U * A * \text{CLTD}_{\text{corr}} \quad (3.1)$$

Where:

U: Overall heat transfer coefficients for doors.

CLTD<sub>corr</sub>: varies with difference Orientation of doors area.

## 2- Inner doors:

Heat gain through inner doors can be calculated by equation (3.2):

$$Q = U * A * \Delta T \quad (3.2)$$

### 3.1.6 Heat Gain Due To Equipment:

Sensible and latent heat loads arising from various equipment and appliances that are installed in conditioned space. The indicated heat dissipation rates from such equipment and appliances should be included when the cooling load is estimated.

### 3.1.7 Heat Gain Due To Lights:

Heat gains due to lights are sensible loads. And can be found by use following equation:

$$Q_{\text{light}} = \dot{w} * CLF \quad (3.7)$$

$\dot{w}$ : Power of light use.

CLF: the light cooling load factor.

### 3.1.8 Heat Gain Due To Ventilation:

Ventilation is required for places in which the inside air is polluted due to activities that take place in these space such as factories, restaurants, closed parking area. this type of load calculated by equation :

$$Q = \left( \frac{V * N}{3600} \right) * \rho * c_p * \Delta T \quad (3.8)$$

Where is :

V: volume of room.

N: number of air change per hour.

$\rho$ : density of air.

$\Delta T$ : difference in temperature.

### 3.1.9 Heat Gain Due To Infiltration:

Infiltration is the leakage of outside air through cracks or clearances around the windows and doors .It provides fresh outside air needed for living comfort and health. The amount of this infiltrated air depends mainly on the tightness of the window and door and on the outside wind speed and its direction or the pressure difference between the outside and inside of the room.

The heat loss due infiltration  $Q_{t.f}$  , is calculated as follows:

$$Q_{t.f} = \left( \frac{V_{inf}}{v_o} \right) * (h_i - h_o) \quad (3.9)$$

Where is:

$h_i$ : Inside enthalpy of infiltrated air in  $\left(\frac{kJ}{kg}\right)$

$h_o$ : outside enthalpy of infiltrated air in  $\left(\frac{kJ}{kg}\right)$ .

$v_o$  : Specifics volume in  $\left(\frac{m^3}{kg}\right)$

$V_{inf}$  :The volumetric flow rate of infiltrated air in  $\left(\frac{m^3}{s}\right)$

$$V_{inf} = V_f * L \quad (3.9.1)$$

Where is :

L: crack length of meter.

$V_f$ : The infiltration rate per unit length for crack.

### 3.2 Heating System

In the villa design, it should supply it by source of heating until to compensate the heat losses to satisfy comfort condition for occupants in the cold months.

Many systems are used for this purpose, such as heating by hot water (hydraulic system) or heating by warm air (duct system) and some time small heaters are used for this purpose but this method rarely used. And there are many criteria that will taken in the consideration to select the suitable system such as efficiency, flexibility, cost, installation, and the type of buildings.

The heating load of the building is comprised with the following components:

- 1) Heat loss through the exposed areas which consist of the walls, the roofs, windows, doors, and walls between the space and unheated spaces.
- 2) Heat required to warm air infiltrated through cracks of windows and doors, and by opening and closing of doors and windows or to warm mechanical ventilation air to the temperature of the space.
- 3) Domestic hot water load.
- 4) Miscellaneous heat load required such as for humidification of outside air, for a safety factor, or for emergencies.

The equation used in the calculation of heat transfer through walls given by:

$$Q = U A (T_i - T_o) \quad (3.10)$$

Where,

Q : is the heat transfer rate.

U : the overall coefficient of heat transfer.

A : the area of the wall.

$T_i$  : is the inside design temperature.

$T_o$  : is the outside design temperature.

### 3.2.1 Heat Loss by Infiltration

Infiltration is the leakage of outside air through cracks and clearances around the windows and doors. The amount of infiltration depends mainly on the tightness of the windows and doors on the outside wind velocity or the pressure difference between the outside and inside the heat load due to infiltration is given by:

$$Q_{t.f} = \left( \frac{V_{inf}}{v_o} \right) * (h_i - h_o) \quad (3.11)$$

Where,

$h_i$ : Inside enthalpy of infiltrated air in  $\left(\frac{kJ}{kg}\right) = 47$

$h_o$ : outside enthalpy of infiltrated air in  $\left(\frac{kJ}{kg}\right) = 12$

$V_{inf}$ : The volumetric flow rate of infiltrated air in  $\left(\frac{m^3}{s}\right)$

$v_o$ : Specific volume in  $\left(\frac{m^3}{kg}\right)$  at  $T_o$  is 0.784

### 3.3 Overall coefficient of heat transfer:

Calculation of “U” for :

#### 1) External wall:

Outside wall of building we have consists of the following material in table (3.1) (the arrangement of material in table from outside to inside).

**Table (3.1) types of material for outside walls**

	<b>Type of material</b>	<b>Thickness (m)</b>	<b>Thermal conductivity W/m. °C</b>
<b>1</b>	Stone	0.05	1.7
<b>2</b>	Concrete	0.2	1.75
<b>3</b>	Insulation	0.03	0.04
<b>4</b>	Cement block with air gap	0.1	1
<b>5</b>	Cement Plaster	0.02	0.8

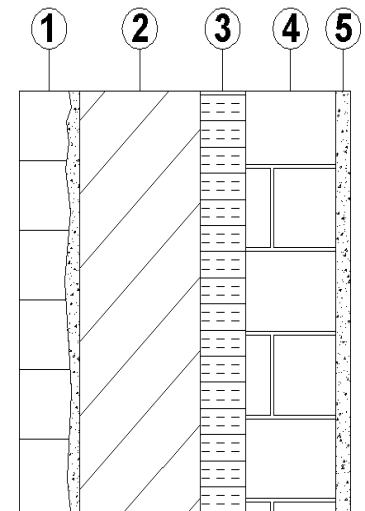

**Figure (3.1) arrangement of material for outside walls**

$$U = \frac{1}{\left(\frac{1}{h_{fin}}\right) + \left(\frac{\Delta x}{K_s}\right) + \left(\frac{\Delta x}{K_c}\right) + \left(\frac{\Delta x}{K_i}\right) + \left(\frac{\Delta x}{K_b}\right) + \left(\frac{\Delta x}{K_m}\right) + \left(\frac{1}{h_{fout}}\right)} \quad (3.14)$$

Where,

$K_s$  : Thermal conductivity of stone .

$K_c$  : Thermal conductivity of concrete.

$K_i$ : Thermal conductivity of insulation.

$K_b$ : Thermal conductivity of block .

$K_m$  : Thermal conductivity of cement plaster.

$h_{fin}$ : convection coefficient of inside air.

$h_{fout}$ : convection coefficient of outside air.

$$u = \frac{1}{\left(\frac{1}{9.37}\right) + \left(\frac{0.07}{1.7}\right) + \left(\frac{0.2}{1.75}\right) + \left(\frac{0.03}{0.04}\right) + \left(\frac{0.07}{1}\right) + \left(\frac{0.03}{0.8}\right) + \left(\frac{1}{22.7}\right)} = 0.86 \text{ W/m}^2 \cdot ^\circ\text{C}$$



## 2)internal wall:

consists of four parts:

A) in general as table (3.2) and figure (3.2) below which represent the construction of internal wall:

**Table (3.2) types of material for internal walls**

	Type of material	Thickness (m)	Thermal conductivity (W/m. °C)
1	Cement plaster	0.02	0.8
2	block	0.1	1
3	Cement plaster	0.02	0.8

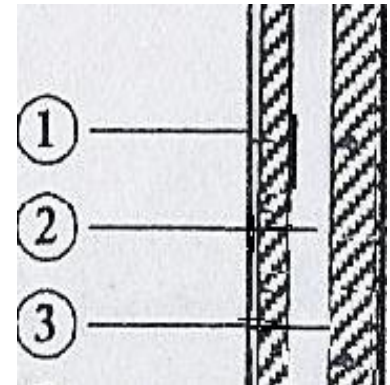

**Figure (3.2) arrangement of material for internal walls**

$$U = \frac{1}{\left(\frac{2}{h_{fin}}\right) + \left(\frac{\Delta x}{Kb}\right) + 2 * \left(\frac{\Delta x}{Km}\right)} \quad (3.15)$$

Then we substitute the magnitude in previous equation to get:

$$u = \frac{1}{\left(\frac{2}{9.37}\right) + \left(\frac{0.1}{1}\right) + 2 * \left(\frac{0.02}{0.8}\right)} = 2.75 \text{ W/m}^2 \cdot \text{°C}$$

**B)** as the figure(3.2) and table (3.2) If thickness block of inside wall = 0.2m:

So:

$$u = \frac{1}{\left(\frac{2}{9.37}\right) + \left(\frac{0.2}{1}\right) + 2 * \left(\frac{0.02}{0.8}\right)} = 2.16 \text{ W/m}^2 \cdot \text{°C}$$

**C)** in bathroom walls, as the figure(3.2) and table (3.2) in addition to mortar layer of thickness = 0.005 m inside for one face:

$$u = \frac{1}{\left(\frac{2}{9.37}\right) + \left(\frac{0.005}{0.72}\right) + \left(\frac{0.1}{1}\right) + 2 * \left(\frac{0.02}{0.8}\right)} = 2.7 \text{ W/m}^2 \cdot \text{°C}$$

D) As Table(3.3) and figure (3.3) below “concrete internal wall with two cement plaster faces”:

**Table (3.3) concrete internal walls with two cement plaster faces**

	Type of material	Thickness (m)	Thermal conductivity (W/m. °C)
1	cement Plaster	0.02	0.8
2	Concrete	0.2	1.75
3	Cement Plaster	0.02	0.8

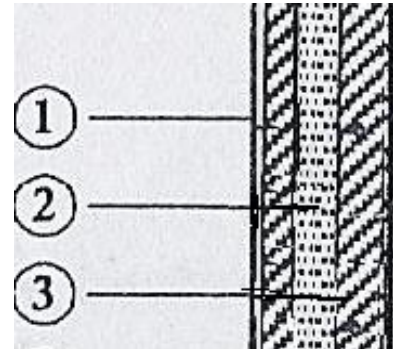

**Figure (3.3) arrangement of material for concrete internal walls**

So:

$$u = \frac{1}{\left(\frac{2}{9.37}\right) + \left(\frac{0.2}{1.75}\right) + 2 * \left(\frac{0.02}{0.8}\right)} = 2.65 \text{ W/m}^2 \cdot \text{°C}$$

### 3) Ceiling:

We choose the ceiling construction for four floors as shown in figure (3.4) below:

**Table (3.4) types of material for ceiling**

NO.	Type of material	Thickness (m)	R <sub>th</sub> (m <sup>2</sup> . °C/W)
1	Asphalt mix	0.02	0.028
2	concrete	0.05	0.029
3	insulation	0.02	0.5
4	Reinforced concrete	0.06	0.034
5	Cement block	0.18	0.189
6	plaster	0.02	0.017

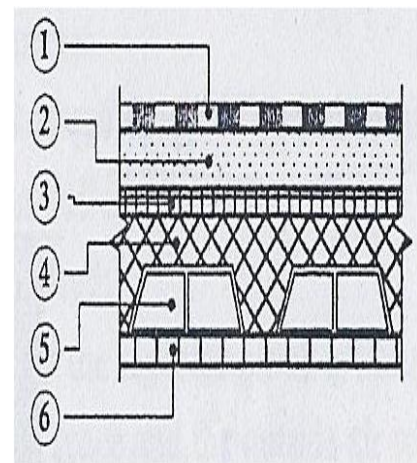

**Figure (3.4) arrangement of material for ceiling**

So:

$$U_{\text{ceiling}} = 1.08 \text{ W/m}^2 \cdot \text{°C}$$

#### 4) Floor:

We choose the floor construction as shown in figure (3.5) below:

**Table (3.5) types of material for floor**

NO.	Type of material	Thickness (m)	Thermal conductivity (W/m. °C)
1	concrete	0.05	1.72
2	insulation	0.02	0.04
3	Reinforce concrete	0.06	1.75
4	plaster	0.02	0.8
5	Ceramic tile	0.025	1.1
6	sand	0.05	1.72
7	Cement block	0.18	1

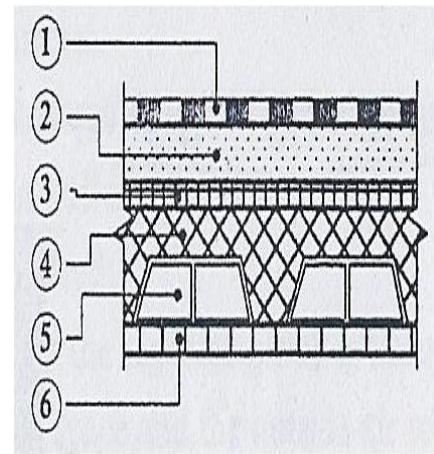

**Figure (3.5) arrangement of material for floor**

So:

$$U = \frac{1}{\left(\frac{2}{h_{fin}}\right) + \left(\frac{\Delta x}{Kt}\right) + \left(\frac{\Delta x}{Ks}\right) + \left(\frac{\Delta x}{Kc}\right) + \left(\frac{\Delta x}{Ki}\right) + \left(\frac{\Delta x}{Krf}\right) + \left(\frac{\Delta x}{Kb}\right) + \left(\frac{\Delta x}{Kp}\right)}$$

$$U = \frac{1}{\left(\frac{2}{9.37}\right) + \left(\frac{0.025}{1.1}\right) + \left(\frac{0.05}{1.72}\right) + \left(\frac{0.05}{1.72}\right) + \left(\frac{0.02}{0.04}\right) + \left(\frac{0.06}{1.75}\right) + \left(\frac{0.18}{1}\right) + \left(\frac{0.02}{0.8}\right)}$$

$$U_{\text{floor}} = 0.97 \text{ W/m}^2 \cdot \text{°C}$$

### 3.4 Sample Calculations For Cooling & Heating Load

For this section we take a Bedroom in third floor as a sample of our load calculation, as shown in figure (3.6).

#### 3.4.1 Sample Of Cooling Load

##### 3.4.1.1 Wall Gain Load

*south outside wall for the room( $A_1$ ):*

$$A_{\text{wall}} = 5.7 * 3.38 = 19.266 \text{ m}^2$$

$$A_1 = A_{\text{wall}} - A_{\text{w14}}$$

$$A_{\text{w14}} = 1.7125 \text{ m}^2$$

We have two window in this wall.

$$A_1 = 19.266 - 2(1.7125) = 15.841 \text{ m}^2$$

$$Q_1 = U * A_1 * CLTD_{\text{corr south.}} = 0.86 * 15.841 * 9.8 = \mathbf{133.51 \text{ W}}$$

*west outside wall for the room( $A_2$ ):*

$$A_{\text{wall}} = 1.9 * 3.38 = 6.422 \text{ m}^2$$

$$A_2 = A_{\text{wall}} - A_{\text{D13}}$$

$$A_{\text{D13}} = 0.9 * 2.74 = 2.466 \text{ m}^2$$

$$A_2 = 6.422 - 2.466 = 3.956 \text{ m}^2$$

$$Q_2 = U * A_2 * CLTD_{\text{corr west}} = 0.86 * 3.956 * 11.6 = \mathbf{39.46 \text{ W}}$$

*west inside wall for the room( $A_3$ ):*

$$A_3 = 1.8 * 2.86 = 5.148 \text{ m}^2$$

$$Q_3 = U * A_3 * \Delta T = 2.75 * 5.148 * 6 = \mathbf{84.94 \text{ W}}$$

*west inside wall for the room( $A_4$ ):*

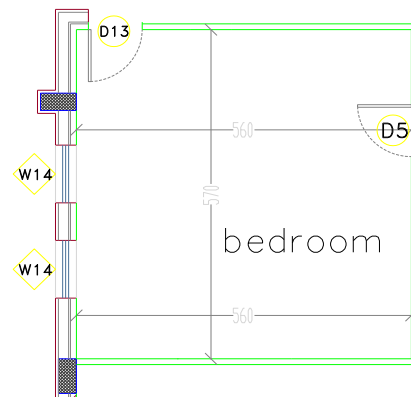

**Figure (3.6)**

**Bedroom as sample of cooling calculation**

$$A_4 = 1.8 * 2.86 = 5.148 \text{ m}^2$$

$$Q_4 = U * A_4 * \Delta T = 2.9 * 5.148 * 6 = \mathbf{89.275 \text{ W}}$$

*north inside wall for the room(A<sub>5</sub>):*

$$A_5 = 1.3 * 2.86 = 3.718 \text{ m}^2$$

$$Q_5 = U * A_5 * \Delta T = 2.16 * 3.718 * 6 = \mathbf{48.185 \text{ W}}$$

*north inside wall for the room(A<sub>6</sub>):*

$$A_6 = A_{\text{wall}} - A_{D5}$$

$$A_{\text{wall}} = 2.86 * 4.4 = 12.584 \text{ m}^2$$

$$A_{D5} = 0.9 * 2.10 = 1.89 \text{ m}^2$$

$$A_6 = 12.584 - 1.89 = 10.697 \text{ m}^2$$

$$Q_6 = U * A_6 * \Delta T = 2.75 * 10.697 * 6 = \mathbf{176.451 \text{ W}}$$

*East inside wall for the room(A<sub>7</sub>):*

$$A_7 = 2.11 * 2.86 = 6.0346 \text{ m}^2$$

$$Q_7 = U * A_7 * \Delta T = 2.75 * 6.0346 * 6 = \mathbf{99.5709 \text{ W}}$$

*East inside wall for the room(A<sub>8</sub>):*

$$A_8 = 3.49 * 2.86 = 9.9814 \text{ m}^2$$

$$Q_8 = U * A_8 * \Delta T = 2.16 * 9.9814 * 6 = \mathbf{129.358 \text{ W}}$$

### **3.4.1.2 Floor & Ceiling Gain Load:**

- *Floor gain load:*

$$A_1 = 5.6 * 5.7 = 31.92 \text{ m}^2$$

$$Q = U_{\text{floor}} * A_1 * \Delta T = 0.97 * 31.92 * 6 = \mathbf{185.77 \text{ W}}$$

- *Roof gain load:*

$$A = 5.6 * 5.7 = 31.92 \text{ m}^2$$

$$Q = U_{\text{roof}} * A * \text{CLTD}_{\text{corr roof}} = 1.08 * 31.92 * 34.1 = \mathbf{1175.55 \text{ W}}$$

### 3.4.1.3 Windows Gain Load:

*W<sub>14</sub> at south wall:*

$$A_{w14} = 1.7125 \text{ m}^2$$

$$Q_w = A(\text{SHG})(\text{SC})(\text{CLF}) = 1.7125 * 227 * 0.51 * 0.68 = 134.8 \text{ W}$$

We have two window in this wall

$$Q_{\text{T windows}} = 2 * Q_{w14} = \mathbf{269.6 \text{ W}}$$

### 3.4.1.4 Doors Gain Load:

1. *External door heat gain:*

The all of outdoor made is aluminum (D<sub>8</sub>)

the overall heat transfer coefficients (U= 7 W/m<sup>2</sup>.C<sup>o</sup>)

$$Q = U * A * \text{CLTD}_{\text{corr.}}$$

- *Q from D<sub>13</sub> to bedroom:*

$$A_{D13} = 2.466 \text{ m}^2$$

$$Q = U * A_{D13} * \text{CLTD}_{\text{corr. west}} = 7 * 2.466 * 11.6 = \mathbf{200.2 \text{ W}}$$

2. *Inner door heat gain:*

$$Q = A * U * \Delta T$$

$$u = \frac{1}{\left(\frac{2}{9.37}\right) + \left(\frac{0.04}{0.11}\right)} = 1.733 \text{ W/m}^2 \cdot \text{ } ^\circ\text{C}$$

$$\Delta T = 6 \text{ C}^\circ$$

- *Q from D<sub>5</sub> to bedroom:*

$$A_{D5} = 1.89 \text{ m}^2$$

$$Q = U * A_{D5} * \Delta T = 1.733 * 1.89 * 6 = \mathbf{19.652 \text{ W}}$$

### 3.4.1.5 Heat Gain Due To Lights:

Heat gains due to light are sensible load, we find used this equation:

$$Q_{\text{light}} = \dot{w} * CLF$$

Clf: cooling load factor = 0.88

Power of one light=50 W

The heat transfer of two light ( $Q_{\text{light}}$ ) =  $2*50*0.88 = \mathbf{88W}$

**Total heat gain for room:  $Q_{\text{cooling}} = 2.77 \text{ kW}$**

### 3.4.2 Sample Of Heating Load

#### 3.4.2.1 Wall Gain Load

*south outside wall for the room( $A_1$ ):*

$$A_{\text{wall}} = 5.7 * 3.38 = 19.266 \text{ m}^2$$

$$A_1 = A_{\text{wall}} - A_{w14}$$

$$A_{w14} = 1.7125 \text{ m}^2$$

We have two window in this wall.

$$A_1 = 19.266 - 2(1.7125) = 15.841 \text{ m}^2$$

$$Q_1 = U * A_1 * \Delta T = 0.86 * 15.841 * (22 - 3) = \mathbf{258.84 \text{ W}}$$

*west outside wall for the room( $A_2$ ):*

$$A_{\text{wall}} = 1.9 * 3.38 = 6.422 \text{ m}^2$$

$$A_2 = A_{\text{wall}} - A_{D13}$$

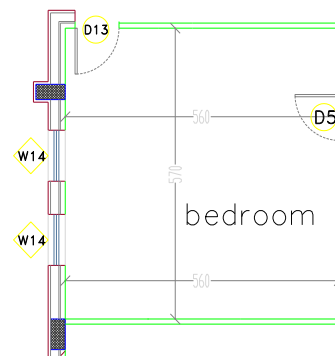

**Figure (3.7)**

**Bedroom as sample of heating calculation**

$$A_{D13} = 0.9 * 2.74 = 2.466 \text{ m}^2$$

$$A_2 = 63422 - 2.466 = 3.956 \text{ m}^2$$

$$Q_2 = U * A_2 * \Delta T = 0.86 * 3.956 * 19 = \mathbf{64.64W}$$

*west inside wall for the room(A<sub>3</sub>):*

$$A_3 = 1.8 * 2.86 = 5.148 \text{ m}^2$$

$$\Delta T_{\text{inside}} = (22 - 3) * 0.5 = 9.5 \text{ }^\circ\text{C}$$

$$Q_3 = U * A_3 * \Delta T_{\text{inside}} = 2.9 * 5.148 * 9.5 = \mathbf{141.8 W}$$

*west inside wall for the room(A<sub>4</sub>):*

$$A_4 = 1.8 * 2.86 = 5.148 \text{ m}^2$$

$$Q_4 = U * A_4 * \Delta T_{\text{inside}} = 2.9 * 5.148 * 9.5 = \mathbf{141.8 W}$$

*north inside wall for the room(A<sub>5</sub>):*

$$A_5 = 1.3 * 2.86 = 3.718 \text{ m}^2$$

$$Q_5 = U * A_5 * \Delta T_{\text{inside}} = 2.16 * 3.718 * 9.5 = \mathbf{76.29 W}$$

*north inside wall for the room(A<sub>6</sub>):*

$$A_6 = A_{\text{wall}} - A_{D5}$$

$$A_{\text{wall}} = 2.86 * 4.4 = 12.584 \text{ m}^2$$

$$A_{D5} = 0.9 * 2.10 = 1.89 \text{ m}^2$$

$$A_6 = 12.584 - 1.89 = 10.697 \text{ m}^2$$

$$Q_6 = U * A_6 * \Delta T_{\text{inside}} = 2.75 * 10.694 * 9.5 = \mathbf{279.38 W}$$

*East inside wall for the room(A<sub>7</sub>):*

$$A_7 = 2.11 * 2.86 = 6.0346 \text{ m}^2$$

$$Q_7 = U * A_7 * \Delta T_{\text{inside}} = 2.75 * 6.0346 * 9.5 = \mathbf{157.6 W}$$

*East inside wall for the room(A<sub>8</sub>):*



$$A_8 = 3.49 * 2.86 = 9.9814 \text{ m}^2$$

$$Q_8 = U * A_8 * \Delta T_{\text{inside}} = 2.16 * 9.9814 * 9.5 = \mathbf{204.8 \text{ W}}$$

### 3.4.2.2 Floor & Ceiling Gain Load:

- *Floor gain load:*

$$A_1 = 5.6 * 5.7 = 31.92 \text{ m}^2$$

$$Q = U_{\text{floor}} * A_1 * \Delta T_{\text{inside}} = 0.97 * 31.92 * 9.5 = \mathbf{294.1 \text{ W}}$$

- *Roof gain load:*

$$A = 5.6 * 5.7 = 31.92 \text{ m}^2$$

$$Q = U_{\text{roof}} * A * \Delta T_{\text{inside}} = 1.08 * 31.92 * 9.5 = \mathbf{655 \text{ W}}$$

### 3.4.2.3 Windows Gain Load:

*W<sub>14</sub> at south wall:*

$$A_{w14} = 1.7125 \text{ m}^2$$

$$Q_w = U * A * \Delta T = 4.065 * 1.7125 * 19 = 132.26 \text{ W}$$

We have two window in this wall

$$Q_{T \text{ windows}} = 2 * Q_{w14} = \mathbf{264.5 \text{ W}}$$

### 3.4.2.4 Doors Gain Load:

3. *External door heat gain:*

The all of outdoor made is aluminum (D<sub>8</sub>)

the overall heat transfer coefficients (U= 7 W/m<sup>2</sup>.C°)

$$Q = U * A * \Delta T$$

- *Q from D<sub>13</sub> to bedroom:*

$$A_{D13} = 2.466 \text{ m}^2$$

$$Q = 7 * 2.466 * 19 = \mathbf{327.98 \text{ W}}$$

4. *Inner door heat gain:*

$$Q = A * U * \Delta T$$

$$u = \frac{1}{\left(\frac{2}{9.37}\right) + \left(\frac{0.04}{0.11}\right)} = 1.733 \text{ W/m}^2 \cdot \text{°C}$$

- *Q from D<sub>5</sub> to bedroom:*

$$A_{D5} = 1.89 \text{ m}^2$$

$$Q = U * A_{D5} * \Delta T_{\text{inside}} = 1.733 * 1.89 * 9.5 = \mathbf{31.1 \text{ W}}$$

### 3.4.2.5 Infiltration Load:

Estimating the volumetric flow rate of infiltrated air into air condition space by using crackage method.

$$V_{\text{inf}} = K * L * (\Delta P)^{2/3} \tag{3.16}$$

*For window :*

$$L = (2 * 1) + (3 * 1.82) * 2 = 614.92 \text{ m}$$

So:

$$V_{\text{inf}} = 0.43 * 14.92 * (7.3)^{2/3}$$

$$V_{\text{inf}} = 24.1 \text{ m}^3/\text{h}$$

$$V_{\text{inf}} = 6.7 * 10^{-3} \text{ m}^3/\text{s}$$

Now by using equation (3.11),

$$Q_{t.f} = \left(\frac{V_{\text{inf}}}{v_o}\right) * (h_i - h_o) \tag{3.11}$$

$$Q_{t.f} = \left( \frac{0.0067}{0.784} \right) * (47 - 12) * 1000$$

$$Q_{t.f} = \mathbf{299 \text{ W}}$$

For door :

$$L = (2 * 2.74) + (3 * 0.9) = 8.18 \text{ m}$$

So:

$$V_{inf} = 0.43 * 8.18 * (7.3)^{2/3}$$

$$V_{inf} = 13.2 \text{ m}^3/\text{h}$$

$$V_{inf} = 3.66 * 10^{-3} \text{ m}^3/\text{s}$$

$$Q_{t.f} = \left( \frac{0.00366}{0.784} \right) * (47 - 12) * 1000$$

$$Q_{t.f} = \mathbf{164 \text{ W}}$$

**Total heat gain for room:  $Q_{\text{heating}} = 3.36 \text{ kW}$**

### 3.5 Tables of Results:

The results of heating and cooling calculations for each floor are tabulated below:

**Table (3.6): Heating & Cooling Load for ground floor**

No. of Room	Heating Load kW	Cooling Load kW
1-1-chancing room	0.82	0.72
1-2- kitchen	1.2	1.9
1-3- living room	4.35	4.15
1-4-bedroom	1.4	1.34
1-5-bath	0.3	0.23

<b>1-6- bathroom 1</b>	<b>0.97</b>	<b>–</b>
<b>1-7- bathroom 2</b>	<b>1.1</b>	<b>–</b>
<b>Sum.</b>	<b>10.14</b>	<b>8.34</b>

**Table (3.7): Heating & Cooling Load for first floor**

<b>No. of Room</b>	<b>Heating Load kW</b>	<b>Cooling Load kW</b>
<b>2-1-office</b>	<b>0.89</b>	<b>0.86</b>
<b>2-2-bedroom 1</b>	<b>1.355</b>	<b>1.24</b>
<b>2-3- bedroom 2</b>	<b>1.79</b>	<b>1.69</b>
<b>2-4-changing room</b>	<b>0.785</b>	<b>0.712</b>
<b>2-5- living room 1</b>	<b>1.8</b>	<b>1.76</b>
<b>2-6- living room 2</b>	<b>2.86</b>	<b>2.21</b>
<b>2-7- kitchen</b>	<b>3.1</b>	<b>4.86</b>
<b>2-8-gaust room</b>	<b>1.99</b>	<b>1.97</b>
<b>2-9- bathroom 1</b>	<b>0.97</b>	<b>–</b>
<b>2-10- bathroom 2</b>	<b>1.1</b>	<b>–</b>
<b>2-11- bathroom 3</b>	<b>0.0078</b>	<b>–</b>
<b>Sum.</b>	<b>16.647</b>	<b>15.122</b>

**Table (3.8): Heating & Cooling Load for second floor**

<b>No. of Room</b>	<b>Heating Load kW</b>	<b>Cooling Load kW</b>
3-1-bedroom1	2.6	2.4
3-2-bedroom 2	2.2	2.12
3-3- bedroom 3	2.29	2.2
3-4-bedroom4	2.1	2
3-5- living room	5.27	5.2
3-8- kitchen	2.4	3.5
3-9- changing room	6.4	6.3
3-10-bath1	0.5	0.455
3-11-bath2	0.56	0.539
3-12-bath3	0.4	0.377
3-13- bathroom 1	1.16	–
3-14- bathroom 2	1.17	–
3-15- bathroom 3	0.0078	–
<b>Sum.</b>	<b>27.06</b>	<b>25.091</b>

**Table (3.9): Heating & Cooling Load for roof floor**

<b>No. of Room</b>	<b>Heating Load kW</b>	<b>Cooling Load kW</b>
4-1- bedroom	3.36	2.77

<b>4-2- living room</b>	<b>4.7</b>	<b>4.6</b>
<b>4-3-Kitchin</b>	<b>5.2</b>	<b>6.3</b>
<b>4-4-Ghanging room</b>	<b>0.98</b>	<b>0.9</b>
<b>4-5 bathroom 1</b>	<b>0.0078</b>	<b>-</b>
<b>4-6 bathroom 2</b>	<b>1.1</b>	<b>-</b>
<b>Sum.</b>	<b>15.35</b>	<b>14.57</b>

- **Total heating load** =  $(Q_{\text{tot(ground floor)}} + Q_{\text{tot(1st floor)}} + Q_{\text{tot(2nd floor)}} + Q_{\text{tot(rooft floor)}}) = 10.14 + 16.647 + 27.06 + 15.35 + 9.753 = \mathbf{69.2 \text{ kW}}$
- **Total cooling load** =  $(Q_{\text{tot(ground floor)}} + Q_{\text{tot(1st floor)}} + Q_{\text{tot(2nd floor)}} + Q_{\text{tot(rooft floor)}}) = 8.34 + 15.122 + 25.091 + 14.57 = \mathbf{63.123 \text{ kW}}$

# **Chapter Four**

## **Plumping and mechanical Systems**

## 4.1 Introduction

Plumbing consist of two main systems which are water supply and drainage distribution systems. It is one of the most essential and vital subjects that there problems face us every day and needs a fast solution to treat it.

Most dwelling and buildings, including those in rural areas are supplied with water from a public water supply system. The design of main water supply for the building needs to take into consideration the actual and anticipated future consumption. Moreover, size of water main pipe, and required pressure of water are essential.

In addition, many of the mechanical systems created to facilitate the life style of the people. The most important of these systems are ventilation for bathrooms and kitchens, fire extinguishing system, and domestic gas distribution system.

Its worthy to indicate that all of the calculations in this chapter were done based on the attached design in the **appendix-C**, and the main finding of these calculations were summarized in the attached bill of quantity in the **appendix-B**.

## 4.2 Water System

### 4.2.1 Calculations for hot and cold water:

To determine the pipe size for cold and hot water we must calculate the water supply fixture unit (WSFU) for each fixture and fixture unit total on each piping run out and determine the minimum flow pressure required at the most remote outlet.

**Example:** To calculate the water supply fixture unit (WSFU) in the Bath room shown.

We have three fixtures (lavatory, shower, water closet with flush tank)each have (WSFU) as follow:



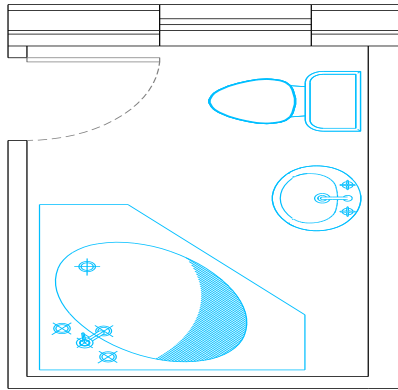

**Figure (4.1) Bathroom**

- 1- lavatory is a fixture with both cold and hot water supplies, so the weights for maximum separate demands may be taken as three-quarters( $3/4$ ) the list demand for the supply in table (4.1), so the lavatory (private) gives 1 WSFU for the total demand (for both cold and hot water) so, for cold water only or hot water only we take  $(3/4 * WSFU = 3/4 * 1 = 3/4)$  &  $(WSFU = 1$  for both cold and hot water).
  
- 2- Water closet is fixture with cold water supply only, so the weights for maximum separate demands may be taken as three -quarters ( $3/4$ ) the list demand for the supply in Table (4.1), so the water closet (private and with flush tank) gives 3 WSFU for the total demand (for both cold and hot water ), so for cold water only or hot water only we take  $(3/4*WSFU=3/4*3=2.25)$  &  $(WSFU=3$ For both cold and hot water).
  
- 3- Bath tub is a fixture with both cold and hot water supplies, so the weights for maximum separate demands may be taken as three –quarters ( $3/4$ ) the list demand for the supply in table (4.1) , so the lavatory (private) gives 2 WSFU for the total demand (for both cold and hot water), so for cold water only or hot water only we take  $(3/4*WSFU=3/4*2=1.5)$  &  $(WSFU=2$  for both cold and hot water).

4- So, from the above information we can do the following table:

Fixture Unit	No. of Units	WSFU from Table(A-1)	Total no. of WSFU for cold water	Total no. of WSFU for hot water	Total no. of WSFU For hot & cold water
Lavatory (private)	1	3/4 * 1	3/4	3/4	1
Bath tub (private)	1	3/4 * 2	1.5	1.5	2
Water closet flush tank (private)	1	3	3	-----	3
-----	-----	-----	$\Sigma = 4.75$ WSFU	$\Sigma = 2.25$ WSFU	$\Sigma = 6$ WSFU

**Table (4.1) WSFU for the Bathroom**

Now we calculate the number of fixture in each floor from mechanical drawing, and so we can do the following table:

Floor name	Total Lavatory	Total Sink	Total Bath tube	Total Shower head	Total Water closet / Flush tank
Ground floor	3	1	1	----	2
First floor	6	1	2	1	4
Second floor	5	1	3	1	4
Roof floor (third floor)	3	1	1	1	2

**Table (4.2) Total number for water supply fixture unit for cold and hot water**

Now we calculate the (WSFU) for each floor as following in tables:

Fixture Unit	No. of Units	WSFU from Table(A-1)	Total no. of WSFU For cold water	Total no. of WSFU For hot water	Total no. of WSFU For hot & cold water
<b>Ground floor</b>	-----	-----	-----	-----	-----
<b>Sink (private)</b>	1	$3/4 * 2$	1.5	1.5	2
<b>Lavatory (private)</b>	3	$3/4 * 1$	2.25	2.25	3
<b>Bath tub (private)</b>	1	$3/4 * 2$	1.5	1.5	2
<b>Water closet flush tank (private)</b>	2	3	6	-----	6
-----	-----	-----	$\Sigma = 11.25$ WSFU	$\Sigma = 5.25$ WSFU	$\Sigma = 13$ WSFU

**Table (4.3) Water supply unit and hot water for ground floor**

Fixture Unit	No. of Units	WSFU from Table(A-1)	Total no. of WSFU For cold water	Total no. of WSFU For hot water	Total no. of WSFU For hot & cold water
<b>First floor</b>	-----	-----	-----	-----	-----
<b>Lavatory(private)</b>	6	$3/4 * 1$	4.5	4.5	6
<b>Sink(private)</b>	1	$3/4 * 2$	1.5	1.5	2
<b>Bath tub (private)</b>	2	$3/4 * 2$	3	3	4
<b>Water closet flush tank(private)</b>	4	3	12	-----	12
<b>Shower head (private)</b>	1	$3/4 * 2$	1.5	1.5	2
-----	-----	-----	$\Sigma = 22.5$ WSFU	$\Sigma = 11.5$ WSFU	$\Sigma = 26$ WSFU

**Table (4.4) Water supply unit and hot water for first floor**

Fixture Unit	No. of Units	WSFU from Table(A-1)	Total no. of WSFU For cold water	Total no. of WSFU For hot water	Total no. of WSFU For hot & cold water
<b>Second floor</b>	-----	-----	-----	-----	-----
<b>Lavatory (private)</b>	5	3/4 * 1	3.75	3.75	5
<b>Sink (private)</b>	1	3/4 * 2	1.5	1.5	2
<b>Bath tub (private)</b>	3	3/4 * 2	4.5	4.5	6
<b>Water closet flush tank</b>	4	3	12	-----	12
<b>Shower head (private)</b>	1	3/4 * 2	1.5	1.5	2
-----	-----	-----	$\Sigma = 23.25$ WSFU	$\Sigma = 11.25$ WSFU	$\Sigma = 27$ WSFU

**Table (4.5) Water supply unit and hot water for second floor**

Fixture Unit	No. of Units	WSFU from Table(A-1)	Total no. of WSFU For cold water	Total no. of WSFU For hot water	Total no. of WSFU For hot & cold water
<b>Roof floor</b>	-----	-----	-----	-----	-----
<b>Lavatory (private)</b>	3	3/4 * 1	2.25	2.25	3
<b>Sink (private)</b>	1	3/4 * 2	1.5	1.5	2
<b>Bath tub (private)</b>	1	3/4 * 2	1.5	1.5	2
<b>Water closet flush tank (private)</b>	2	3	6	-----	6
<b>Shower head (private)</b>	1	3/4 * 2	1.5	1.5	2

-----	-----	-----	$\Sigma = 12.75$ WSFU	$\Sigma = 6.75$ WSFU	$\Sigma = 15$ WSFU
-------	-------	-------	--------------------------	-------------------------	-----------------------

**Table (4.6) Water supply unit and hot water for roof floor**

**4.2.2 Flow rate calculations:**

**To calculate flow rate in gpm:**

FOR GROUND FLOOR:

By using **table (A-2 / Appendix A)** for supply system predominantly for flush tank for ground floor the estimating demand in gpm for cold water = **11.25 WSFU**.

**So, by using interpolation = 8.75 gpm.**

Now we calculate the (gpm) for each floor so, (gpm) for each floor as in the following tables:

No. of Floor	Total no. of WSFU For cold water	Total no. of WSFU For hot water	Total no. of WSFU For hot & cold water	Total no. of gpm For cold water	Total no. of gpm For hot water	Total no. of gpm For hot & cold water
Ground floor	11.25	5.25	13	8.75	5	9.8
First floor	22.5	11.5	26	15.5	8.9	17.6
Second floor	23.25	11.25	27	16	10.6	18.2
Roof floor	12.75	6.75	15	9.65	5.6	11
				$\Sigma = 49.9$	$\Sigma = 30.1$	$\Sigma = 56.6$

**Table (4.7) Water supply unit and hot water for roof floor**

#### 4.2.2.1 Sizing hot water heaters:

- ❖ For 9 person uses the Villa :
  - For first two person :  $2p * 50 \text{ L / day / person} = \mathbf{100 \text{ L / day}}$
  - For 7 person others :  $7p * 30 \text{ L / day / person} = \mathbf{210 \text{ L / day}}$
  - The sum of the consumption =  $310 \text{ L / day}$
  - The sum of the consumption =  $310 \text{ L / day} * 0.2641 \text{ gal / L} = \mathbf{81.7 \text{ gal / day}}$
- ❖ We have 4 dishwasher and 2 clothes washer in the building so, from **table (A-3)** (see **Appendix –A**) :
  - For dishwashers :  $4 * 15 \text{ gal / dishwasher / day} = \mathbf{60 \text{ gal / day}}$
  - For clothes washers:  $2 * 40 \text{ gal / clothes washer / day} = \mathbf{80 \text{ gal / day}}$
  - The sum of this =  $\mathbf{140 \text{ gal / day}}$ 
    - ❖ Daily total consumption =  $140 \text{ gal / day} + 81.7 \text{ gal / day} = \mathbf{221.7 \text{ gal / day}}$
    - ❖ Maximum hourly demand (portion of daily use) =  $1 / 7$  of daily use =  $221.7 * (1/7) = \mathbf{32 \text{ gal/hr}}$
    - ❖ Duration of peak load =  $4 \text{ hr}$
    - ❖ Total peak load =  $4 * 32 = \mathbf{128 \text{ gal}}$
    - ❖ The storage capacity =  $1/5$  of daily use :  $1/5 * 221 = \mathbf{44.2 \text{ gal}}$
    - ❖ We choose  $(44.2 / 0.264) = 167.4 \text{ ft}^3 \approx \mathbf{200 \text{ ft}^3}$
    - ❖ Required recovery =  $(\text{total peak load} - \frac{3}{4} \text{ storage capacity}) / \text{duration of peak load}$   
 $= 128 - (3/4 * 44.2) / 4 = \mathbf{23.7 \text{ gal /hr}}$
    - ❖ The remaining quantity in the heater at peak time =  $\mathbf{23.7 \text{ gal /hr}}$

And, The remaining quantity in the heater at peak time < maximum hourly demand

**So,  $23.7 < 32$  and this means it is sufficient.**

#### 4.2.2.2 Calculations of water pipes' diameters:

- ❖ **The maximum instantaneous water demand on:**
  - The amount of total water demand for cold water =  $49.9 \text{ gpm}$
  - The amount of total water demand for hot water =  $30.1 \text{ gpm}$

So, the total demand for cold and hot water =  $\mathbf{80 \text{ gpm}}$

❖ **The available mains pressure at the level outlet is:**

– Main pressure = static head pressure + friction head pressure + main flow pressure

❖ **Static head = [ height of floors + height of water tank + height of stairs well – height of fixture unit]**

– Height of floors from planes = 14.51m

– Height of stairs well from planes = 2.39m

– Height of water tank as selected = 2m

– Height of sink = 1.05m

– So, the static head =  $14.51 + 2.39 + 2 - 1.05 = 17.85 \text{ m} = \mathbf{54 \text{ ft}}$

– Static pressure =  $54 \text{ ft} * 0.433 = \mathbf{23.4 \text{ psi}}$

❖ **Total equivalent length (TEL):** the distance from water tanks to the collector in ground floor + distance from collector to fixture unit

– TEL = longest run \* 1.5

– Longest run =  $2.39 + 7.43 + 3.52 + 14.51 + 0.57 + 0.33 + 0.13 + 5.93 + 1.05 = 35.86 \text{ m}$   
 $= 108.6 \text{ ft}$

– TEL =  $108.6 * 1.5 = \mathbf{163 \text{ ft}}$

❖ **Main flow pressure of the critical fixture = 8 psi**

❖ **Friction head = static pressure – main flow pressure =  $23.4 - 8 = \mathbf{15.4 \text{ psi}}$**

– Uniform friction loss = friction head / TEL =  $15.4 / 163 = 15.4 / (1.63 * 100) = \mathbf{9.4 \text{ psi} / 100 \text{ ft}}$

#### 4.2.2.3 Selection of water pipes diameters :

By using chart of friction head loss (**figure A-1 / Appendix A**) for galvanized steel pipes we select diameters of pipes refer to calculated values of the main pipe that supply cold water from tanks to distribution points on the roof .The diameter is 2" refer to calculated values for flow rate (80 gpm) , and friction head loss (9.4 psi/100ft)

The following table shows the diameters of hot and cold water pipes for all floors :

No. of floor	No. of collector	Total load of hot water (gpm)	Total load of cold water (gpm)	Friction of head loss	Diameter of hot water pipe	Diameter of cold water pipe
<b>Floor ground</b>	Collector	5 (gpm)	8.75(gpm)	9.4	3/4"	3/4"
<b>First floor</b>	Collector No.1	3 (gpm)	7.8 (gpm)	9.4	1/2"	3/4"
	Collector No. 2	5.5(gpm)	9.6 (gpm)	9.4	3/4"	1"
<b>Second floor</b>	Collector No.1	6 (gpm)	10 (gpm)	9.4	3/4"	1"
	Collector No.2	5.5(gpm)	9.6 (gpm)	9.4	3/4"	1"
<b>Roof floor</b>	Collector	5.5(gpm)	9.6 (gpm)	9.4	3/4"	1"

**Table (4.8) Diameter of pipe sizing of water supply in inch for each floor**

### 4.3 Sanitary Drainage system

#### 4.3.1 Septic Tank

Where there is no sanitary sewer systems available, it is necessary to provide private sewage treatment facilities that will handle all the effluent from a building's fixtures, including black and gray water.

When there is adequate area around the house and the soil is absorbent (sandy soil), the problem is easily solved, but with clay-type soil, the problem is more difficult.

In densely populated areas with houses on 40\*100 ft lots, the situation is very difficult.

The sewage fluids enters the septic tank, solids sink to the bottom of the tank. Bacterial action breaks up the solids and aids in purifying the fluids. A very small amount of sludge slowly builds up at the bottom of the tank and a scum forms at the top surface of the contents.



The outflow pipe that carries the liquid effluent into the surrounding earth is located and protected in a way that prevents its being clogged.

The septic tank needs to be pumped out at intervals because of sludge accumulation every (5-10) years.

❖ **To calculate size of septic tank:**

The building has nine bedrooms, so average number of persons in building is  $9 * 2 = 18$  person.

**Table (A-4 / Appendix A)** shows the minimum capacity of septic tanks for different uses, for single family dwellings 9 bedrooms so, 2250 gal is the minimum capacity of septic tank is 2250 gal, so we better select a tank that is one size larger than the minimum, that is, a 2500 gal tank is selected.

Note that :  $1 \text{ ft}^3 = 7.481 \text{ gal}$

So a septic tank of  $2500 / 7.481 = 334.2 \text{ ft}^3$  required.

### **4.3.2 Manhole Design**

We design the manholes around the building so as that the sewage comes from the stacks in, then the sewage flow from one manhole to another so as reaching the septic tank.

The design of the manholes depend on the ground and its nature around the building, and so as the first manhole height should not be less than 50 cm. and then we calculate the height of the other manhole depending on the spacing between manholes and the slope of drainage pipes between manhole to be 1.5%.

As a result of these calculation we estimate the invert level of the manhole that is the depth of the pipe entering the manhole. And we chose the diameter of the manhole depending on the depth of the manhole. As below:

- ❖  $\Phi 60$  cm for manhole depth (50-100)cm.
- ❖  $\Phi 80$ cm for manhole depth (100-150)cm.
- ❖  $\Phi 100$ cm for manhole depth (150-250)cm.
- ❖  $\Phi 120$ cm for manhole depth >250cm.

### ❖ 4.3.3 Manhole calculations:

We assume the depth of the first manhole to be 50 cm and we calculate the second manhole according to it and so on,

#### ❖ For manhole No.1 :

Top level = +2.89

Depth = 0.5

Invert level=top level-depth = +2.89 - 0.5 = +2.39

#### ❖ For manhole No. 2 :

The distance between manhole 1 & manhole 2 is 0.95m

Invert level for manhole 2 is:

$$Y = ((S * \text{Slope}) + 5) / 100$$

Where :s is the distance between manhole 1 & manhole 2

Slope is 1.5%

5cm is the point in manhole 2 where the pipe will be connected.

So:

$$Y = ((8.78 * 5) + 5) / 100$$

$$= ((8.78 * 1.5) + 5) / 100$$

$$= 0.182$$

Top level = +**2.89**

Invert level of manhole 2 = invert level of M<sub>1</sub> - Y = 2.39 - 0.183 = **2.213**

Depth = T.L<sub>M2</sub> - I.L<sub>M2</sub> = 2.89 - 2.213 = **0.683 m**

The following table shows calculations and dimensions of all manholes that used in our project :

Manhole No.	Top level (m)	Invert level (m)	Depth (m)	Diameter (m)	Cover type
M <sub>1</sub>	+2.89	+2.39	0.50	0.60	Medium duty
M <sub>2</sub>	+2.89	+2.213	0.74	0.60	Medium duty
M <sub>3</sub>	+2.89	+2.07	0.82	0.60	Medium duty
M <sub>4</sub>	+2.89	+1.98	0.91	0.60	Medium duty
D.M. <sub>1</sub>	+2.89	+1.33	1.83	1.00	Medium duty
D.M. <sub>2</sub>	+1.58	+1.46	1.96	1.00	Medium duty
M <sub>5</sub>	+0.12	-0.38	0.50	0.60	Medium duty
M <sub>6</sub>	+0.12	-1.3	1.42	0.80	Medium duty
M <sub>7</sub>	+0.12	-0.38	0.50	0.60	Medium duty
M <sub>8</sub>	+0.12	-0.48	0.60	0.60	Medium duty
M <sub>9</sub>	+0.12	-0.58	0.70	0.60	Medium duty
M <sub>10</sub>	+0.12	-0.78	0.90	0.80	Medium duty
M <sub>11</sub>	+0.12	-1.01	1.13	0.80	Medium duty
M <sub>12</sub>	+0.12	-1.18	1.30	0.80	Medium duty

**Table (4.9) Manholes calculations**

**Example:**

Here we will talk about the choose of diameter and slope of the drainage pipe system and we will take the following Bathroom as an example of how we will choose the diameter and the slope of the drainage pipe system.

1. We will use pipes (branches) from fixture unit to the floor drainage (F.D.) with diameter (2") for lavatory and shower and with slope( 2%)
2. We will use pipes (building drains) from fixture unit to the manhole with diameter (4") for water closet with flush valve and with slope (1% - 2%)
3. We will use pipes (sewage pipes) between manholes with diameter (6") and with slope (1.5%) and the waste water will transfer between manholes until it reach the main manhole.
4. We will use floor trap (F.T.) at the end of the branches as a collection box for this pipes and in order to provide a water seal to prevent odors, sewage gases and vermin's from entering building.
5. We will use clean out (C.O.) at the end of the branches in order to clean the pipes from any things that can blockage and close the pipes.
6. We will use a stack with diameter (4") in order to drain the waste water to the manholes.

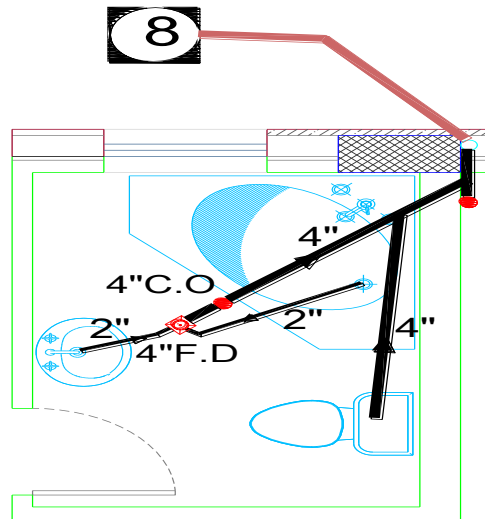

**Figure (4.2) Sanitary drainage for Bathroom**

#### **4.3.4 Drainage piping fill**

1. Branches are designed to run maximum of 50% fill.
2. Stacks are designed to flow between 25 – 30 % maximum.
3. Building drains and sewer drains may be designed over 50% fill.

#### **4.3.5 Drainage piping velocity**

1. For branches the recommended velocity is 2 ft/s
2. For building the recommended velocity is 3 ft/s
3. For greasy the recommended velocity is 4 ft/s

#### **❖ Velocity of water flow through drainage piping depends on:**

1. Pipe diameter.
2. Slope.

For the same diameter large pipe diameter required lower slope

For pipes of diameter  $\leq 3"$  the minimum slope is 1/4 in/ ft

For pipes of diameter  $\geq 4"$  the minimum slope is 1/8 in/ ft

#### 4.4 ventilation system

A ventilation is a system which circulates fresh air throughout a confined space or spaces, while removing contaminated or stale air. Ventilation systems are used in various settings, including homes and workplaces.

One of the main objectives of ventilation is the removal or the reduction of the produced contaminants. Mechanical ventilation is required for places in which the inside air is polluted due to activities that take place in these spaces such as closed areas.

There are various types of ventilation systems, which are typically classified as natural or mechanical systems. A natural ventilation system relies on atmospheric conditions, while a mechanical system is a man-made device that assists in the filtration and circulation of the air. The most common form of a natural system consists of an outlet on the roof and openings throughout the lower part of a building. This allows air to rise and exit through the roof, and new air to enter from below, providing constant circulation.

The flow rate of ventilation air required to remove or reduce a certain contaminant is given by the following relationship :

$$V^0 = V * N \quad (4.1)$$

Where ,

V: volume of room (m<sup>3</sup>).

N: number of air change per hour.

##### 4.4.1 Sample of Ventilation Calculations

Ventilation system in the project are applied for all kitchens and bathrooms in the building , and the following is a sample of calculations for kitchen and bathrooms in ground floor:

*For kitchen:*

$$V^0 = V * N$$

$$V = 3.7 * 2.5 * 2.86 = 26.455 \text{ m}^3$$

N : number of air change per hour for kitchens = 2

$$V^0 = 26.455 * 2 = 52.91 \text{ m}^3 / \text{h} = \mathbf{31.12 \text{ CFM}}$$
 (Cubic Feet per Minute)

For bathroom(1):

$$V^0 = V * N$$

$$V = 1.9 * 2.7 * 2.86 = 14.67 \text{ m}^3$$

N : number of air change per hour for bathrooms = 3

$$V^0 = 14.67 * 3 = 44 \text{ m}^3 / \text{h} = \mathbf{25.8 \text{ CFM}}$$
 (Cubic Feet per Minute)

The following table shows the flow rate of ventilation of all kitchens and bathrooms for each floor.

The flow rate of ventilation (CFM)					
floor	Kitchen	Bathroom (1)	Bathroom (2)	Bathroom (3)	Bathroom (4)
ground	31.12	25.8	11.3	_____	_____
first	98.4	25.8	11.3	25.4	23
second	69.6	28.6	28.6	62.8	18
roof	69.6	18	62.8	_____	_____

**Table (4.10) flow rate of ventilation for kitchens & bathrooms for each floor**

## 4.5 Fire Extinguishing system

Fire extinguishing system divided into two parts:

1. sprinklers system that used in factories and commercial buildings.
2. Cabinet tubes that used in homes.

The system that used in the project is cabinet tube that consists from water cabinets placed on each floor in the medium and suitable place so that they can access water to every point in the floor.

### 4.5.1 Fire extinguishing system calculation

- ❖ Dimension of fire fighting cabinets that has been used is ( 0.30 \* 0.80 \* 1.8) m, contain water hose has diameter of (1") and length ranges from (25 – 30) m. The hose made from

rubber material and has a nozzle valve at the end to increase the speed of water at the outlet.

- ❖ The pipes that feed the cabinets with water from the roof of the building is galvanized seamless steel pipe work at ASTM A53 grade (A) schedule (40)
- ❖ Diameter of main pipe that distribute water to cabinets is (1.5") and (1.4") pipe for each cabinet.
- ❖ The building consists of four floors, each floor needs a Cabinet with store capacity of (100) gpm. Finally, the total actual needs is (400) gpm in addition to (100) gpm as spare.

➤ *Fire extinguishing water tanks calculations:*

- ❖ Calculating the volume of water tanks used in fire extinguishing system must take into consideration the distance between the building and the fire station and the time required to reach fire car.

Time required to reach fire car is 30 minute, and  $30 * 500 \text{ gpm} = (1500) \text{ gpm}$  in addition to (500) gpm as spare. Finally the total actual needs is (2000) gpm.

- ❖ So, four water tanks have been selected to cover the required quantity each one has capacity of (500) gpm.
- ❖ Height of water tanks from the ground ranges between ( 90 – 100 ) cm to obtain the required pressure at hose nozzle.

➤ *Fire extinguishing pump:*

- ❖ Electrical pump, store capacity of (100) gpm, and (4.5) bar head has been selected to the system.

#### **4.6 Gas distribution system**

Domestic gas was used in the building for cooking purposes only and It was distributed to the kitchens from gas cylinders each one has capacity of (48) Kg by copper gas pipes ( 8mm ,12 mm) protected with plastic material.

# **Chapter Five**

**VARIABLE REFRIGERANT**

**FLOW SYSTEM**

**VRV**



## 5.1 Introduction

Variable refrigerant volume (VRV) systems, which were introduced in Japan more than 20 years ago, have become popular in many countries. The technology has gradually expanded its market presence, reaching European markets in 1987, and steadily gaining market share throughout the world. VRV systems are used in approximately 50% of medium sized commercial buildings (up to 6,500 m<sup>2</sup>).

VRV systems are larger in capacity, more complex versions of the ductless multisplit systems, with the additional capability of connecting ducted style fan coil units. They require many evaporators and complex oil and refrigerant management and control system. Also, they need a separate ventilation system.

The term variable refrigerant flow refers to the ability of the system to control the amount of refrigerant flowing to each of the evaporators. This enables the use of many evaporators of different capacities and configurations, individualized comfort control, simultaneous heating and cooling in different zones, and heat recovery from one zone to another. This refrigerant flow control lies at the heart of VRV systems and is the major technical challenge as well as the source of many of the systems advantages.

Many HVAC professionals are familiar with ductless mini split products. A variation of this product, often referred to as a multi split, includes multiple indoor evaporators connected to a single condensing unit see figure (5-1). Ductless products are fundamentally different from ducted systems. VRV air-conditioning system is in power air-conditioning system, by controlling the amount of circulating refrigerant compressor and access to indoor heat exchanger refrigerant flow in a timely manner to meet the requirements of indoor hot and cold load .

The main advantage of a VRV system is its ability to respond to fluctuations in space load conditions by allowing each individual thermostat to modulate its corresponding electronic expansion valve to maintain its space temperature set point.

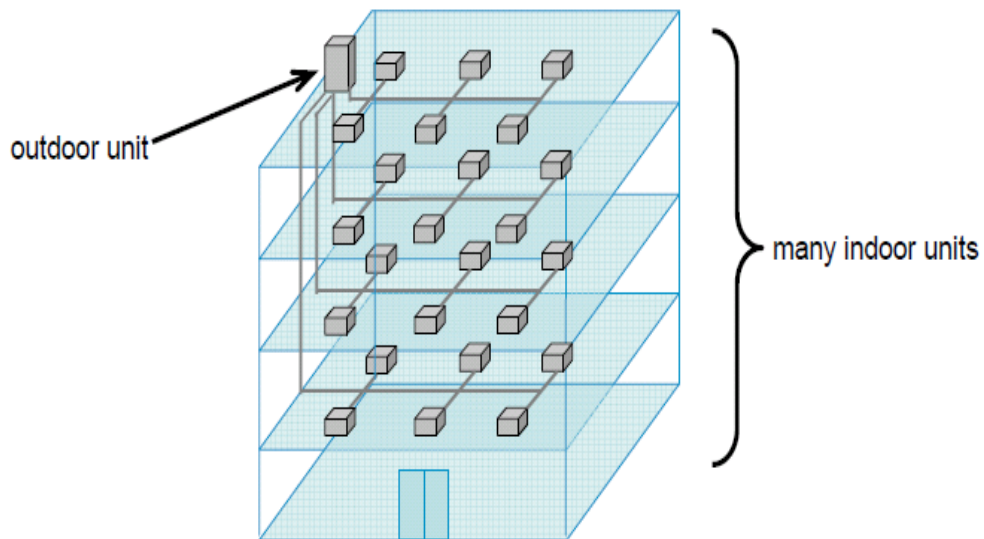

**Figure 5.1: Distribution units, internal and external**

Figure (5-2) shows main components of VRV system that includes outdoor unit that contains inverter compressor, heat exchanger and multiple indoor units that contain fan coil and electronic expansion valve.

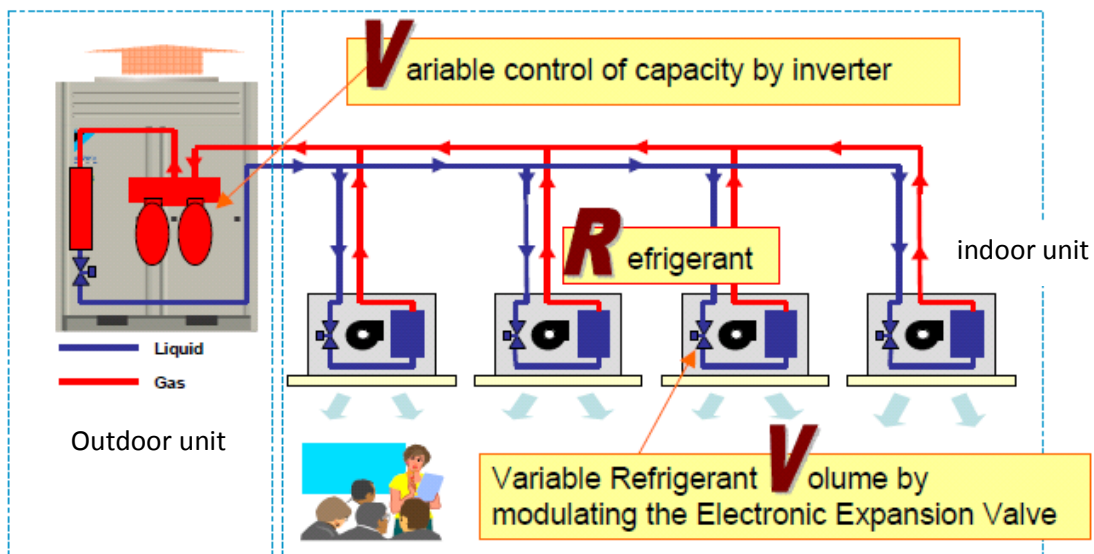
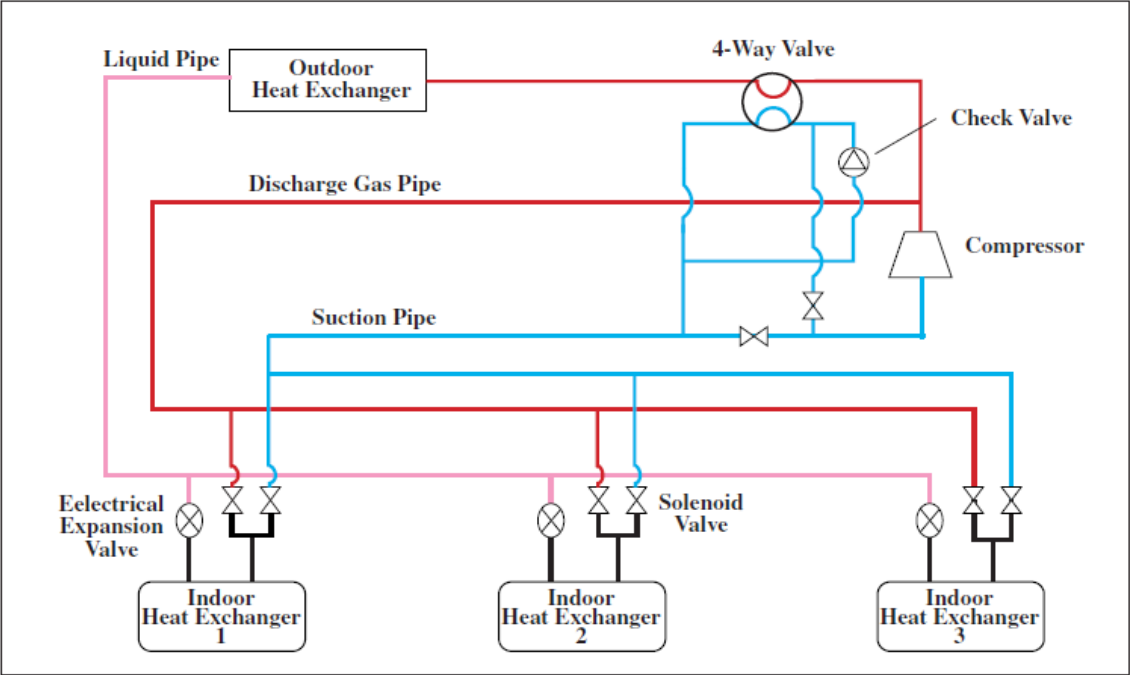

**Figure 5.2 : main components of VRV system**

## 5.2 Refrigerant Cycle And Components

Figure (5.3) shows the concept of Basic Refrigeration Cycle for VRV system that includes either a two-pipe (liquid and suction gas) or three-pipe (liquid, suction gas, and discharge gas) configuration. Using a control system, refrigerant is pumped through pipes to

individually sized configured evaporators in each space, each of which can have its own thermostat. It's a closed-loop system so refrigerant is continuously circulated, VRV air conditioning systems need to use inverter compressor to achieve the combination of compressor capacity control and electronic expansion valve to regulate access to indoor unit refrigerant flow.



**Figure 5.3 Basic Refrigeration Cycle for VRV**

**5.3 Inverter Compressor**

VRV system use inverter controller that enables compressor speed to vary according to the cooling/heating load and therefore consume only the power necessary to match that load. The 50 Hz frequency of the power supply is inverted to a higher or lower frequency according to the required capacity to heat or cool the room. If a lower capacity is needed, the frequency is decreased and less energy is used. Under partial load conditions, the energy efficiency is higher. If the compressor rotates more slowly because less capacity is needed, the coil becomes virtually oversized. Improved efficiencies can therefore be achieved than are possible with non inverter compressors, which always run at the same speed.

## 5.4 Types Of VRV

There are two basic types of VRV multi-split systems: heat pump and heat recovery. Heat pumps can operate in heating or cooling mode. A heat-recovery system, by managing the refrigerant through a gas flow device, can simultaneously heat and cool, some indoor fan coil units in heating and some in cooling, depending on the requirements of each building zone.

### 5.4.1 Cooling Operation

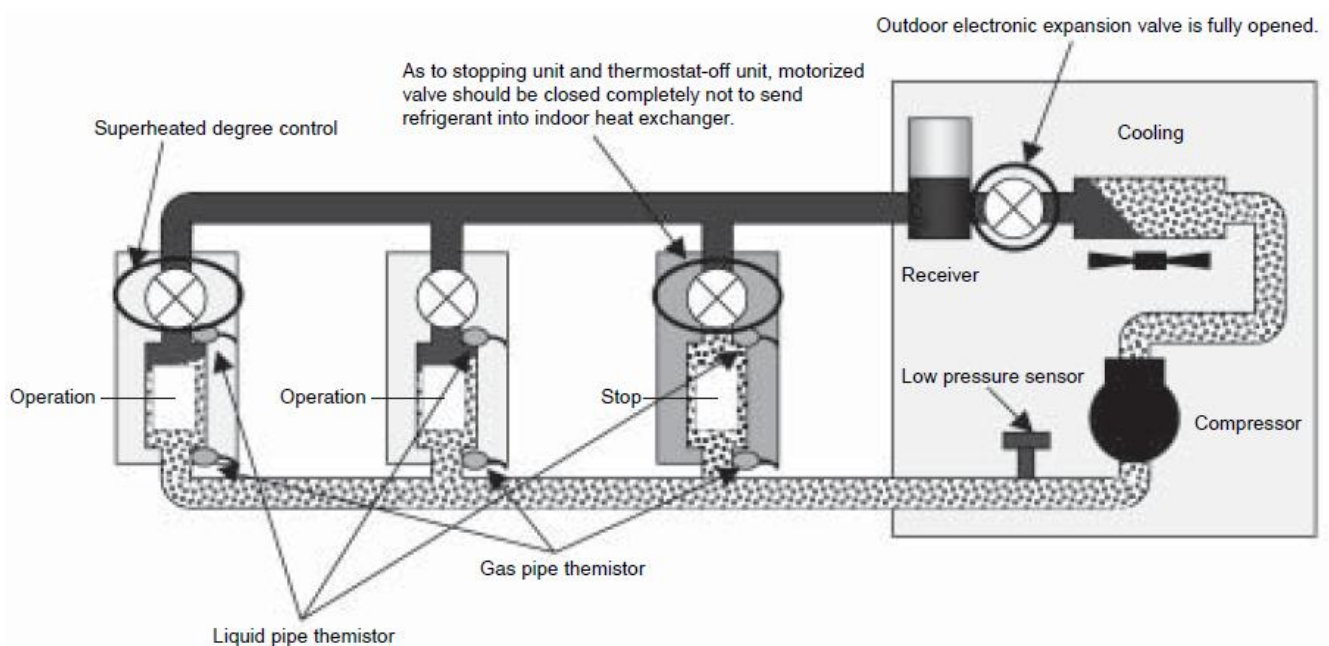

**Figure 5.4: Schematic diagram for cooling operation**

To maintain the cooling capacity corresponding to the capacity of evaporator and load fluctuation, based on the pressure detected by low pressure sensor of outdoor unit ( $P_e$ ), the compressor capacity is so controlled to put the low pressure equivalent saturation temperatures (evaporation temperature =  $T_e$ ) close to target value. In order to maintain the superheated degree in evaporator and to distribute proper refrigerant flow rate in spite of different loads on every indoor unit, based on the temperature detected by thermostats of liquid pipes and gas pipes, indoor electronic expansion valve is so regulated as to put superheated degree at evaporator outlet close to target value. Superheated degree equal (indoor gas pipe temperature – indoor liquid pipe temperature).

## 5.4.2 Heating Operation

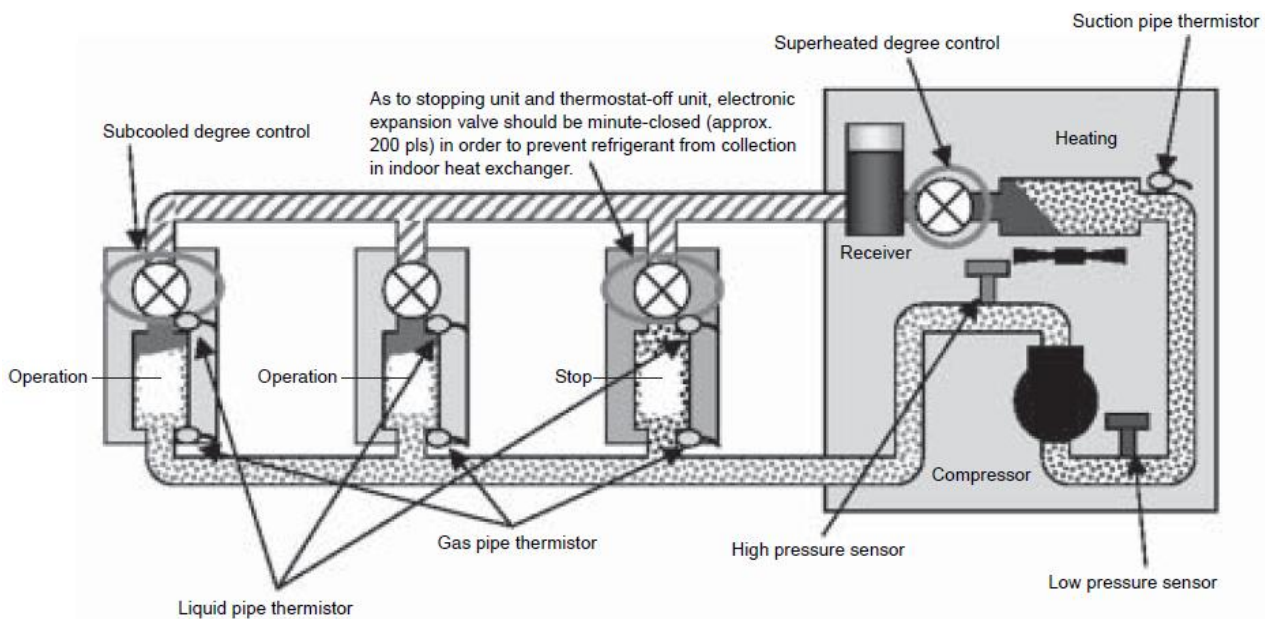

**Figure 5.5: Schematic diagram for heating operation**

To maintain the heating capacity against condenser capacity and load fluctuation, based on the pressure detected by high-pressure sensor control ( $P_c$ ), compressor capacity is so controlled to put the high pressure equivalent saturation temperature (condensing temperature  $T_c$ ) close to target value. In order to maintain the superheated degree in evaporator, based on the pressure detected by the low pressure sensor ( $T_e$ ) and the temperature detected by the thermostat of suction pipe, outdoor electronic expansion valve is so controlled as to put superheated degree at evaporator outlet close to target value. Superheated degree equal (outdoor suction pipe temperature – outdoor evaporating temperature).

In order to distribute proper refrigerant flow rate in spite of different loads on every indoor unit, based on the pressure detected by the high pressure sensor of outdoor unit ( $T_c$ ) and the temperature detected by the thermostat of indoor liquid pipes, indoor electronic expansion valve is so controlled as to put subcooled degree at condenser outlet close to target value. Subcooled degree equal (outdoor condensing temperature – indoor liquid pipe temperature).

### 5.4.2.1 Heating And Defrost Operation

In heating mode, VRV systems typically must defrost like any mechanical heat pump, using reverse cycle valves to temporarily operate the outdoor coil in cooling mode. Oil return and balance with the refrigerant circuit is managed by the microprocessor to ensure that any oil entrained in the low side of the system is brought back to the high side by increasing the refrigerant velocity using a high-frequency operation performed automatically based on hours of operation.

The fan coils are constant air volume, but use variable refrigerant flow through an electronic expansion valve. The electronic expansion valve reacts to several temperature-sensing devices such as return air, inlet and outlet refrigerant temperatures, or suction pressure. The electronic expansion valve modulates to maintain the desired set point.

### 5.4.2.2 Heat Recovery Operation

Heat recovery operation is achieved using either 3 pipes or 2 pipes (depending on manufacturer). See figure. 5.6 and 5.7 . The 2 pipe heat recovery system has a central branch controller with two pipes from the outdoor unit and 2 pipes to each indoor unit . For mixed mode operation the branch controller separates a mixture of saturated liquid and vapor delivered by the outdoor unit so that each indoor can receive high pressure liquid or vapor. In both cases the liquid produced by indoor units in heating mode is then used to serve indoor units in cooling mode and improved energy saving is possible.

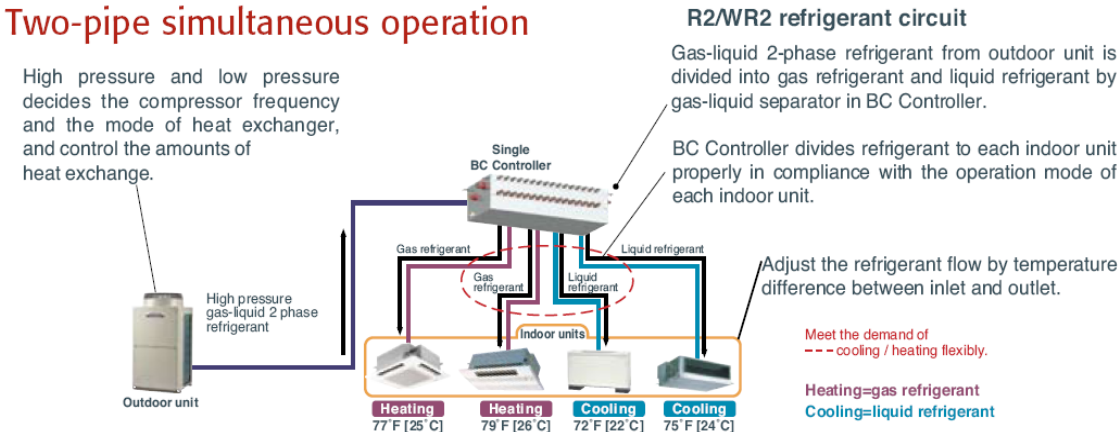
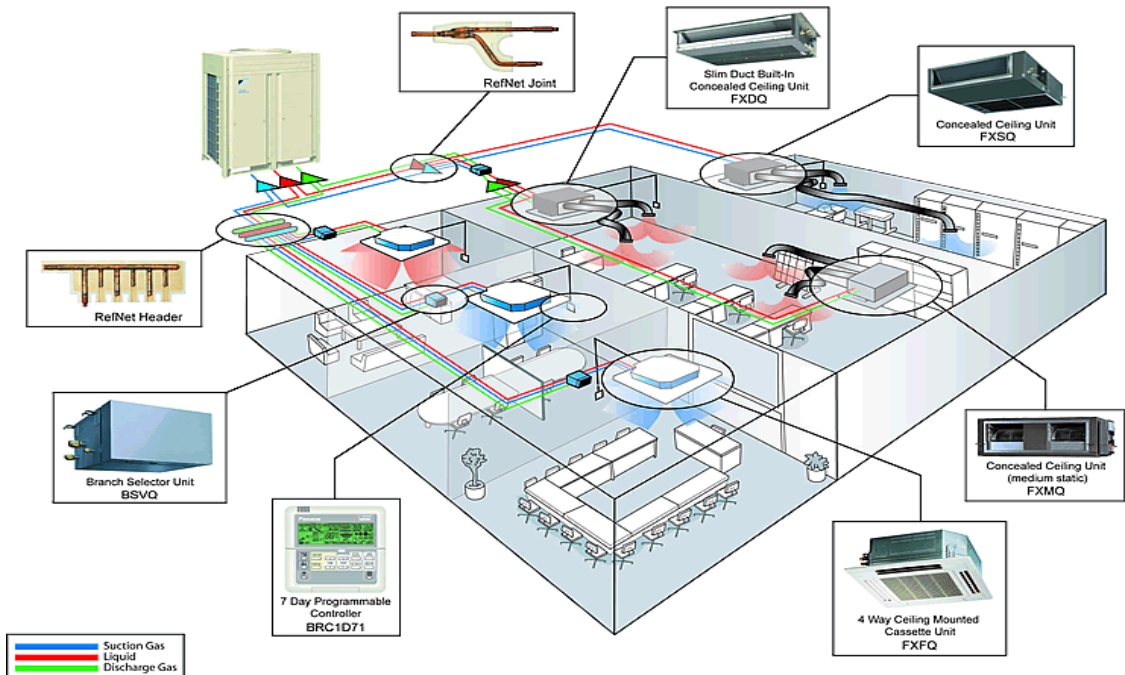

Figure 5.6 Two pipe heat recovery system

The three pipe heat recovery system has a liquid line, a hot gas line and a suction line from the outdoor unit. Each indoor unit is branched off from the 3 pipes using solenoid valves. An indoor unit requiring cooling will open its liquid line and suction line valves and act as an evaporator. An indoor unit requiring heating will open its hot gas and liquid line valves and will act as a condenser.



**Figure 5.7 pipe heat recovery system**

**5.5 Features**

**5.5.1 High-Performance VRV System For Cold Climate**

VRV system’s energy efficiency is higher than that of normal duct systems. The VRV essentially eliminate duct losses, which are often estimated to be between 10%~20% of total airflow in a ducted system. VRV systems typically include two or three compressors. This approach yields high part-load efficiency, which translates into high seasonal energy efficiency, because HVAC systems typically spend most of their operating hours in the range of 40% to 80% of maximum capacity. For buildings requiring simultaneous heating and cooling, heat recovery VRV systems can be used. These systems circulate refrigerant between zones, transferring heat from indoor units of zones being cooled to those of zones being heated.

The most sophisticated VRV systems can have indoor units, served by a single outdoor unit, in both heating and cooling modes simultaneously. This mixed mode operation leads to energy savings as both ends of the thermodynamic cycle are delivering useful heat exchange. If a system has a cooling COP (Coefficient of Performance) of 3, and a heating COP of 4, then heat recovery operation could yield a COP as high as 7. It should be noted that this perfect balance of heating and cooling demand is unlikely to occur for many hours each year, but whenever mixed mode is used energy is saved. In mixed mode the energy consumption is dictated by the larger demand, heating or cooling, and the lesser demand, cooling or heating is delivered free. Units are now available to deliver the heat removed from space cooling into hot water for space heating, domestic hot water or leisure applications, so that mixed mode is utilized for more of the year.

**5.5.2 Operation Range**

VRV can be Installation in extreme temperature conditions is possible due to an increase in operational range cooling mode can be operated from : -15°C to 46°C and heating mode can be operated from -20°C to 21°C see figure 5.8 below.

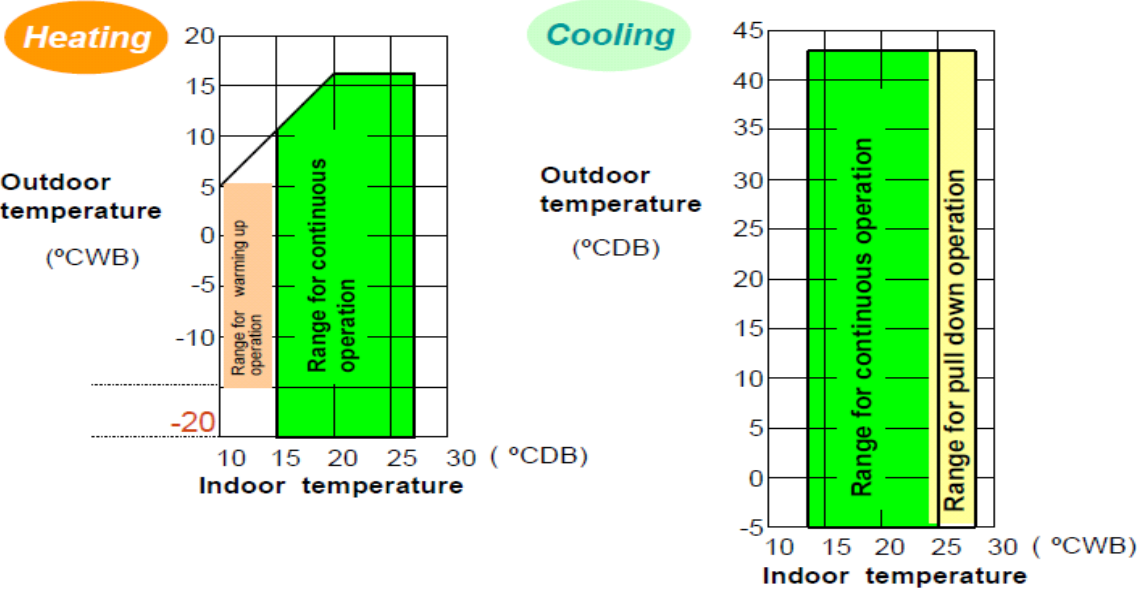

**Figure5.8 Operation Range**



### 5.5.3 Low Noise Mode

Two low noise modes can be selected automatically by quiet priority setting and capacity priority setting depending on the usage environment and outside temperature load. Reductions in outdoor unit sound pressure levels have been achieved via:

- redesigned fan blades and inlet bell mouth
- a new high efficiency aero spiral fan with backward curved blade tips that reduce air turbulence and pressure loss.
- the redesigned bell mouth air inlet fitted with guide vanes at the intake that also reduces air turbulence around the blades.

Using the latest technology, sound pressure levels down to 47 dB(A) in cooling (3 HP) are achieved. The sound pressure levels therefore up to 3 dB(A) lower than those of standard fixed speed models.

### 5.5.4 Precision Refrigerant Flow Control

Precision and Smooth refrigerant flow control is achieved by using a DC Inverter control in conjunction with individual indoor unit electronic expansion valve control. This allows for a high precision comfortable temperature control of  $\pm 0.5^{\circ}\text{C}$ . Figure 5.9 shows the difference between inverter air condition and Traditional air condition, inverter air condition use PI controller (proportional and integral) that response to the temperature of the air deviating from the setpoint, the proportional and integral control signals occur simultaneously. The proportional component provides a relatively fast response to the deviation from the setpoint. The integral component is used to drive the controlled variable back toward the setpoint, eliminating the offset characteristic of proportional control. The two signals are additive.

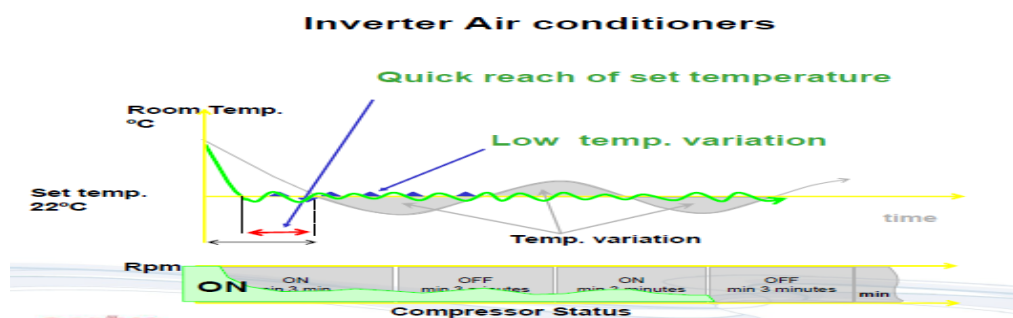
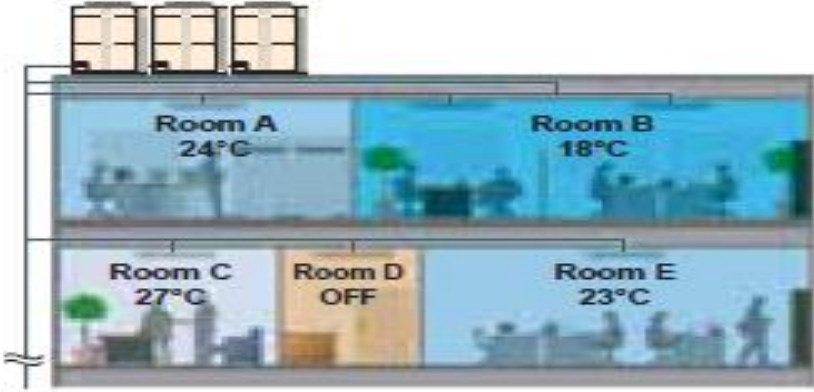

Figure 5.9 Inverter air conditioners

**5.5.5 Individual Air Conditioning Control**

The desired temperature conditions of each room are met due to the Individual thermostat control of each indoor unit see Figure (5.10)



**Figure 5.10 Individual Air Conditioning Control**

**5.5.6 Continuous Operation During Maintenance**

Non-stop operation When servicing a specific indoor unit, maintenance can be performed even without turning off the other indoor units figure 5.11

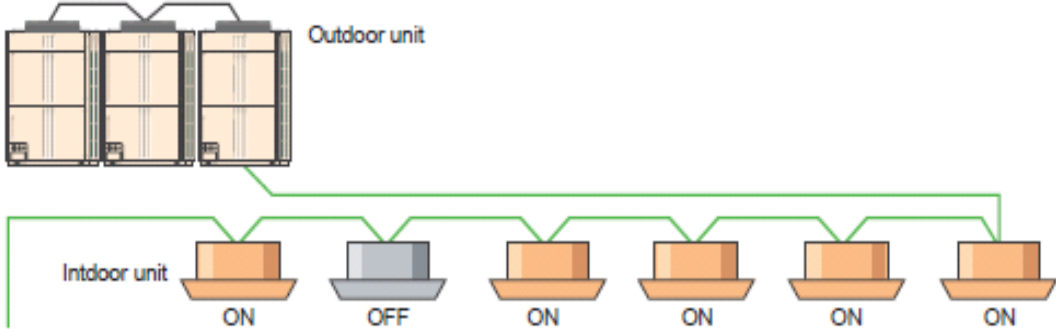

**Figure 5.11 Continuous operation scheme**

### **5.5.7 Space saving**

The VRV system allows you to use the available space more efficiently. Instead of having to incorporate a machine room in to your building plans, you can use this space for other purposes, such as a garage.

## **5.6 General Design Consideration**

### **5.6.1 User Requirements**

The user primarily needs space conditioning for occupant comfort. Cooling, dehumidification, and air circulation often meet those needs, although heating, humidification, and ventilation are also required in many applications. Components other than the base outdoor and indoor units may need to be installed for VRV systems to satisfy all requirements.

### **5.6.2 Diversity And Zoning**

The complete specification of a VRV system requires careful planning. Each indoor section is selected based on the greater of the heating or cooling loads in the area it serves. In cold climates where the VRV system is used as the primary source for heating, some of the indoor sections will need to be sized based on heating requirements.

Once all indoor sections are sized, the outdoor unit is selected based on the load profile of the facility. An engineer can specify an outdoor unit with a capacity that constitutes anywhere between 70% and 130% of the combined indoor units capacities. The design engineer must review the load profile for the building so that each outdoor section is sized based on the peak load of all the indoor sections at any given time. Adding up the peak load for each indoor unit and using that total number to size the outdoor unit likely will result in an unnecessarily oversized outdoor section.

Although an oversized outdoor unit in a VRV system is capable of operating at lower capacity, avoid over sizing unless it is required for a particular project due to an anticipated future expansion or other criteria. Also, when indoor sections are greatly oversized, the modulation function of the expansion valve is reduced or entirely lost. Most manufacturers offer selection software to help simplify the optimization process for the system's components.

### **5.6.3 Installation**

In deciding if a VRV system is feasible for a particular project, the designer should consider building characteristics; cooling and heating load requirements; peak occurrence; simultaneous heating and cooling requirements; fresh air needs; electrical and accessibility requirements for all system components; minimum and maximum outdoor temperatures; sustainability; and acoustic characteristics. The physical size of the outdoor section of a typical VRV is somewhat larger than that of a conventional condensing unit, with a height up to 6 ft. (1.8 m) excluding supports. The chosen location should have enough space to accommodate the condensing unit(s) and any clearance requirements necessary for proper operation.

### **5.6.4 Maintenance Considerations**

Ductless VRV indoor units have some considerations in reference to maintenance:

- Draining condensate water from the indoor and outdoor units
- Changing air filters
- Repairs
- Cleaning

Ease of maintenance depends on the relative position of the indoor and outdoor units and the room to ensure access for changing filters, repairing, and cleaning. The installer must make sure there is enough slope to drain condensate water generated by both the indoor and outdoor units. Depending on the location where the indoor unit is installed, it may be necessary to install a pump so that water drains properly.

### **5.6.6 Sustainability**

VRV systems feature higher efficiencies in comparison to conventional heat pump units. Less power is consumed by heat-recovery VRV systems at part load, which is due to the variable speed driven compressors and fans at outdoor sections. The designer should consider other factors to increase the system efficiency and sustainability. Again, sizing should be carefully evaluated.

Environmentally friendly refrigerants such as R-410A should be specified. Relying on the heat pump cycle for heating, in lieu of electric resistance heat, should be considered, depending on outdoor air conditions and building heating loads. This is because significant

heating capacities are available at low ambient temperatures (e.g., the heating capacity available at 5°F (– 15°C) can be up to 70% of the heating capacity available at 60°F (16°C), depending on the particular design of the VRV system).

### 5.7 Advantages And Disadvantages Of VRV

VRV systems have many advantages over more traditional HVAC units. The advantages and disadvantages for a VRV system, when compared to a chilled system, are presented in Table (5.1)

Item	Description	Chilled Water AC System	Variable Refrigerant Flow AC System
1	Human Comfort	Partial – no humidity control, not so good air distribution	Good – true air conditioning
2	Process cooling, heating, humidification and dehumidification	Not applicable - no humidity control, not so good air distribution	Good - May be designed for any condition
3	Internal Air Quality	Partial – needs a auxiliary air make-up system and special filters No duct work is good	Good – may be designed for any condition. Ducts need to be cleanable
4	Initial Cost	Similar	Similar
5	Operational Cost	Little higher at full load 1.25 kW/ton	At full load 1.18 kW/ton
6	Cooling capacity	Good performance until 100 m equivalent length Poor performance above 100 m equivalent length	Distance is only a matter of pumps' selection and operational power consumption
7	Increasing cooling capacity	Not so easy, it may be necessary to change the refrigerant lines and the condensing unit	It could be done by changing the control valves and or the coils. Chiller plant doesn't change or chilled water pipes

<b>8</b>	Operation at partial load	Good performance and control	Good performance and control
<b>9</b>	Customer or tenant control on the operational cost	Good - full control Very important	No control on the operational and maintenance cost
<b>10</b>	Compatibility with standards, guides and regulations	Partial. It is necessary to solve the compatibilities issue during the design	Fully compatible
<b>11</b>	Long distance pipes	Up to 100 m is OK, more there is a cooling capacity reduction up to 75%	No problem.
<b>12</b>	Refrigerant management	Difficult it depends on the design of the system for monitoring, identification and repair	Concentrate in a single equipment easy and simple – Good
<b>13</b>	Customer operation	Easy and simple – Good Very important	Not so clear to customer - Acceptable
<b>14</b>	Malfunction Possibility	To many parts and components and long refrigerant lines – Acceptable	More reliable, just a few parts and equipment – Good
<b>15</b>	Operational life expectation	Up to 15 years - Acceptable	Up to 25 years – Good
<b>16</b>	Maintenance	Depends on the design, access may be a problem	No problem - Good
<b>17</b>	Sales strategy	It is necessary to verify, the say what the customer would like to listen, but not all is true	Too much engineering stuff, difficult for the costumer to understand

**Table (5.1) advantages and disadvantages for a VRV system**

# **Chapter Six**

## **VRV Components Selection**

## 6.1 Introduction

VRV system contains several important components ,one of these elements outdoor units ,which its capacity must be suit with the loads and it contains indoor units, and there is many models of outdoor and indoor units and the system consists of copper piping and control equipment.

All VRV system components for this project have been selected from SAMSUNG company catalogs because it provides the specifications and conditions that achieve the desired objectives of the air conditioning system in addition to availability in the local market.

The selection components of VRV System consist of :

- a. Selection indoor units.
- b. Selection outdoor units of VRV system.
- c. Selection refrigerant copper pipes.
- d. Selection Y- joint .

## 6.2 Indoor Units

VRV indoor units are modern, technologically advanced and come in ceiling mounted cassette, concealed ceiling, ceiling suspended, wall mounted and floor standing models. Recently, the range has been extended by the visually striking and much acclaimed round flow ceiling mounted cassette with its unique 360° air flow distribution pattern.

Designed to fit rooms of any size and shape, SAMSUNG indoor units are also user friendly, quiet running, ultra reliable, easy to control and supply users with that relaxing 'extra something' to the indoor climate.

VRV air conditioning brings summer freshness and winter warmth to offices, hotels, department stores and many other commercial premises. It enhances the indoor environment and creates a basis for increased business prosperity and whatever the air conditioning requirement.

And this is the model of indoor unit ( Noe Forte type) which is used in the project.





**Figure (6.1) Wall mounted indoor unit, capacity range (2.2 - 7.1 kW)**

Selection process has been done by using specifications catalogue of this type of indoor unit (Tables A-5, A-6, A-7 / Appendix -A), depending on the heating and cooling load calculated for each room.

The following tables show the results of selection the indoor unit for each room to all floors.

No. of Room	Cooling Load kW	Actual Cooling kW	Heating Load kW	Actual Heating kW	Nominal Capacity kW	Model
1- Bedroom & changing room	2.06	2.3	2.22	2.8	2.8 (028)	AVXWNH028E*
2-kitchen	1.9	2.3	1.2	2.8	2.8 (028)	AVXWNH028E*
3-Living Room	4.15	4.6	4.35	5.6	5.6 (056)	AVXWNH056E*

**Table (6.1) Model of indoor units for ground floor rooms**

No. of Room	Cooling Load kW	Actual Cooling kW	Heating Load kW	Actual Heating kW	Nominal Capacity kW	Model
1- Bedroom (1) & changing room	1.952	2.3	2.14	2.8	2.8 (028)	AVXWNH028E*
2- Office	0.86	1.8	0.89	2.3	2.2 (022)	AVXWNH022E*

<b>3- Bedroom (2)</b>	1.69	1.8	1.79	2.3	2.2(022)	AVXWNH022E*
<b>4- Living Room (1)</b>	3.5	4.6	2.4	5.6	5.6(056)	AVXWNH056E*
<b>5- Living Room (2)</b>	5.2	5.5	5.27	6.2	7.1(071)	AVXWNH071E*
<b>6- kitchen</b>	4.86	5.5	3.1	6.2	7.1(071)	AVXWNH071E*
<b>7- Guest Room</b>	1.97	2.3	1.99	2.8	2.8(028)	AVXWNH028E*

**Table (6.2) Model of indoor units for first floor rooms**

<b>No. of Room</b>	<b>Cooling Load kW</b>	<b>Actual Cooling kW</b>	<b>Heating Load kW</b>	<b>Actual Heating kW</b>	<b>Nominal Capacity kW</b>	<b>Model</b>
<b>1- Bedroom (1) &amp; changing room</b>	3.112	4.6	3.385	5.6	5.6(056)	AVXWNH056E*
<b>2- Bedroom (2)</b>	2.12	2.3	2.2	2.8	2.8(028)	AVXWNH028E*
<b>3- Bedroom (3)</b>	2.2	2.3	2.29	2.8	2.8(028)	AVXWNH028E*
<b>4- Bedroom (4)</b>	2	2.3	2.1	2.8	2.8(028)	AVXWNH028E*
<b>5- Living Room</b>	5.2	5.5	5.27	6.2	7.1(071)	AVXWNH071E*
<b>6- kitchen</b>	3.5	4.6	2.4	5.6	5.6(056)	AVXWNH056E*

**Table (6.3) Model of indoor units for second floor rooms**

No. of Room	Cooling Load kW	Actual Cooling kW	Heating Load kW	Actual Heating kW	Nominal Capacity kW	Model
1- Bedroom & changing room	3.67	4.6	4.34	5.6	5.6(056)	AVXWNH056E*
2- Living Room	4.6	4.6	4.7	5.6	5.6(056)	AVXWNH056E*
3- Kitchen	3.5	4.6	2.4	5.6	5.6(056)	AVXWNH056E*

**Table (6.4) Model of indoor units for third floor rooms**

### 6.3 Outdoor Unit

Outdoor unit with a capacity that constitutes anywhere between 70% and 130% of the combined indoor units capacities. The design engineer must review the load profile for the building so that each outdoor section is sized based on the max load of all the indoor sections at any given time. Although an oversized outdoor unit in a VRV system is capable of operating at lower capacity, avoid over sizing unless it is required for a particular project due to an anticipated future expansion or other criteria. Also, when indoor sections are greatly oversized, the modulation function of the expansion valve is reduced or entirely lost. Most manufacturers offer selection software or catalogue to help simplify the optimization process for the system's components, Figure( 6.2) show outdoor units shape.



**Figure (6.2) Outdoor unit**

### ❖ Outdoor unit selection

Outdoor unit selection depends on the total cooling and heating loads capacity of the building as following :

- Total cooling outdoor capacity = cooling indoor capacity / capacity ratio = 58.044 / 1.3 = **45 Kw**
- Total heating outdoor capacity = heating indoor capacity / capacity ratio = 54.435 / 1.3 = **42 Kw**

And refer to outdoor capacity tables from catalogue of outdoor units (**Table A-8 / Appendix A**) we selected 20hp unit consists of two units each one has 10hp with model type (RVXVHT100GE).



**Figure (6.3) Outdoor unit ( 20 hp)**

## 6.4 General Pipes Design

The pipes which used in VRV system is copper pipes. VRV offers an extended piping length of 165m (190m equivalent piping length) with a total system piping length of 1,000m.

In case the outdoor unit is located above the indoor unit the height difference is 50m standard. It can be extended to 90m .In case the outdoor unit is located below the indoor unit, the height difference is 40m standard. Height differences up to maximum 90 more possible .After the first branch, the difference between the longest piping length and the shortest piping length can be maximum 40m,provided that the longest piping length amounts to maximum 90m.

The figure below show the length of the pipes between outdoor units and indoor units.

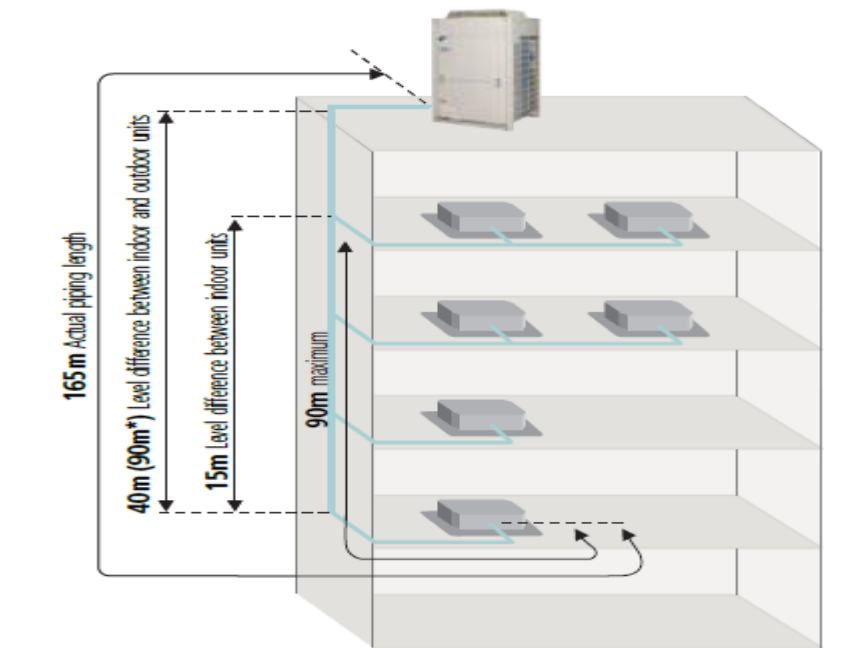

**Figure (6.4) Pipes length between outdoor & indoor units**

The VRV piping of the refrigeration system is one of the most important designs of the VRV system, i.e. the VRV piping should assure many purposes such as:

1. Ensure adequate velocity to return oil to compressor at all steps of unloading.
2. Avoid excessive noise.
3. Minimize system capacity and efficiency loss and pipe erosion.

The VRV piping design of the system requires designing the liquid line that supplies the indoor cooling unit with liquid refrigerant, and the refrigerant suction line; which returns refrigerant from the indoor unit to the compressor.

### **6.4.1 Liquid Line**

This section of pipe conducts warm, high-pressure liquid refrigerant from the condenser to the expansion device and indoor unit .

The liquid line must be designed and installed to ensure that only liquid refrigerant (no vapor) enters the expansion device. The presence of refrigerant vapor upstream of a expansion valve can result in erratic valve operation and reduced system capacity. In order to meet this requirement, the condenser must provide adequate subcooling, and the pressure drop through the liquid line and accessories must not be high enough to cause flashing upstream of the expansion device. Subcooling allows the liquid refrigerant to experience some pressure drop as it flows through the liquid line, without the risk of flashing.

The diameter of the liquid line must be as small as possible to minimize the refrigerant charge, therefore improving reliability and minimizing installed cost. However, if the pipe is too small, the increased pressure drop may cause flashing upstream of the expansion device.

The refrigerant velocity in the liquid line shouldn't exceed 3 m/s to prevent noise and large pressure drops. And no under limit since the refrigerant will solute the oil and carry it by the way. As shown in Figure (6-5); the refrigerant velocity is about 2.8 m/s at the recommended liquid line diameter from the condensation unit manufacturer.

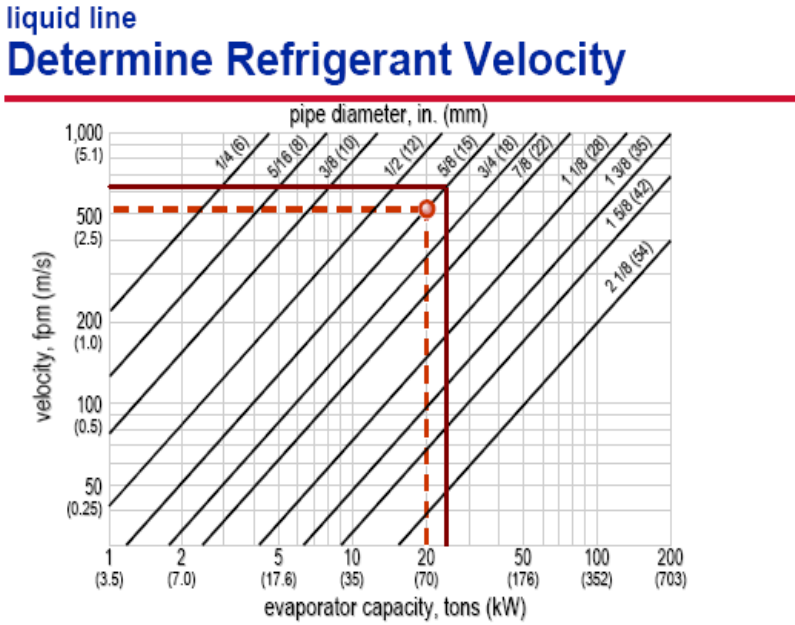

**Figure (6.5) Evaporator capacity and velocity diagram for liquid line**

**6.4.2 Suction Line**

This pipe conducts low pressure refrigerant vapor from the evaporator to the compressor. The diameter of the suction line must be small enough that the resulting refrigerant velocity is sufficiently high to carry oil droplets, at all steps of compressor unloading. The refrigerant velocity inside a pipe depends on the mass flow rate and density of the refrigerant if the velocity in the pipe is too high, however, objectionable noise may result. Also, the pipe diameter should be as large as possible to minimize pressure drop and thereby maximize system capacity and efficiency.

All pipes selection done by using refrigerant piping works catalogue (**Table A-9 / Appendix A**), depends on the capacity of units or joints the pipes that supply them refrigerant.

**6.4.3 Unified REFNET piping**

The unified SAMSUNG refnet piping system is especially designed for simple installation. The use of refnet piping in combination with electronic expansion valves, results in a dramatic reduction in imbalance in refrigerant flowing between indoor units, despite the small diameter of the piping.

refnet joints and headers (both accessories) can cut down on installation work and increase system reliability. Compared to regular T-joints, where refrigerant distribution is far from optimal, the SAMSUNG refnet joints have specifically been designed to optimize refrigerant fl . The figure below show type of refnet.

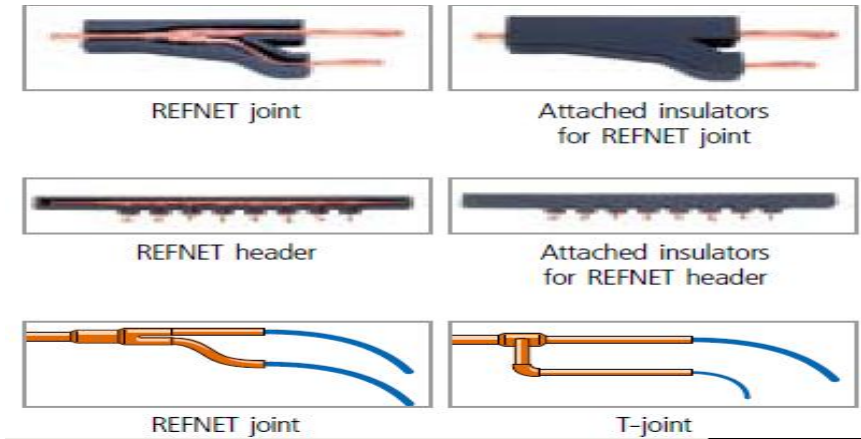

**Figure (6.6) Types of REFNET**

All REFNETS selection done by using refrigerant piping works catalogue (**Table A - 9 / Appendix A**) depends on the capacity of units that refnets supply them refrigerant.

### **6.5 Limitation of VRV system**

Although the high installation cost of the VRV systems and limitation bellow:

- There is a limitation on the indoor coil maximum and minimum entering dry- and wet-bulb temperatures, which makes the units unsuitable for 100% outside air applications especially in hot and humid climates.
- The cooling capacity available to an indoor section is reduced at lower outdoor temperatures. This limits the use of the system in cold climates to serve rooms that require year-round cooling.

It has many features such as high efficiency operation design versatility high reliability easy installation comfort and convenience easy service and maintenance .



## References

- [1] Heating and Air Conditioning , for residential Buildings., fourth edition .SI Version. International edition.
- [2] Refrigeration & Air conditioning Technology; sixth edition
- [3] J.P.Holman .Heat Transfer .Southern Methodist University. Ninth edition .Boston.1996.
- [4] Arnell.N.1996, PLUMPING SYSTEM, 1<sup>st</sup> ed, john wiley & sons, New York.
- [5] SAMSUNG Air Conditioner 2009, DVM Technical Data Book.

# APPENDIX—A

Table 9.3 Water Supply Fixture Units and Fixture Branch Sizes

Fixture <sup>a</sup>	Use	Type of Supply Control	Fixture Units <sup>b</sup>	Min. Size of Fixture Branch <sup>d</sup> in.
Water closet <sup>c</sup>	Private	Flushometer	8	—
Water closet <sup>c</sup>	Private	Flush tank for closet	6	—
Bathtub	Private	Faucet	2	1/2
Bathtub	General	Faucet	4	1/2
Clothes washer	Private	Faucet	2	1/2
Clothes washer	General	Faucet	4	1/2
Combination fixture	Private	Faucet	3	1/2
Dishwasher <sup>f</sup>	Private	Automatic	1	1/2
Drinking fountain	Offices, etc.	Faucet 3/8 in.	0.25	1/2
Kitchen sink	Private	Faucet	2	1/2
Kitchen sink	General	Faucet	4	1/2
Laundry trays (1-3)	Private	Faucet	3	1/2
Lavatory	Private	Faucet	1	3/8
Lavatory	General	Faucet	2	1/2
Separate shower	Private	Mixing valve	2	1/2
Service sink	General	Faucet	3	1/2
Shower head	Private	Mixing valve	2	1/2
Shower head	General	Mixing valve	4	1/2
Urinal	General	Flushometer	5	3/4 <sup>e</sup>
Urinal	General	Flush tank	3	1/2
Water closet	Private	Flushometer	6	1
Water closet	Private	Flushometer/tank	3	1/2
Water closet	Private	Flush tank	3	1/2
Water closet	General	Flushometer	10	1
Water closet	General	Flushometer/tank	5	1/2
Water closet	General	Flush tank	5	1/2

Water supply outlets not listed above shall be computed at their maximum demand, but in no case less than the following values:

Fixture Branch <sup>d</sup>	Number of Fixture Units	
	Private Use	General Use
3/8	1	2
1/2	2	4
3/4	3	6
1	6	10

<sup>a</sup> For supply outlets likely to impose continuous demands, estimate continuous supply separately and add to total demand for fixtures.

<sup>b</sup> The given weights are for total demand. For fixtures with both hot and cold water supplies, the weights for maximum separate demands may be taken as three-quarters the listed demand for the supply.

<sup>c</sup> A bathroom group for the purposes of this table consists of not more than one water closet, one lavatory, one bathtub, one shower stall or one water closet, two lavatories, one bathtub or one separate shower stall.

<sup>d</sup> Nominal I.D. pipe size.

<sup>e</sup> Some may require larger sizes—see manufacturer's instructions.

<sup>f</sup> Data extracted from Code Table B.5.2.

Source. Reproduced with permission from The National Standard Plumbing Code, published by The National Association of Plumbing Heating Cooling Contractors.

TABLE A-1 Water supply fixture units and fixture sizes

**Table 9.4 Table for Estimating Demand**

<i>Supply Systems Predominantly for Flush Tanks</i>		<i>Supply Systems Predominantly for Flushometers</i>	
<i>Load, WSFU<sup>a</sup></i>	<i>Demand, gpm</i>	<i>Load, WSFU<sup>a</sup></i>	<i>Demand, gpm</i>
6	5	—	—
10	8	10	27
15	11	15	31
20	14	20	35
25	17	25	38
30	20	30	41
40	25	40	47
50	29	50	51
60	33	60	55
80	39	80	62
100	44	100	68
120	49	120	74
140	53	140	78
160	57	160	83
180	61	180	87
200	65	200	91
225	70	225	95
250	75	250	100
300	85	300	110
400	105	400	125
500	125	500	140
750	170	750	175
1000	210	1000	218
1250	240	1250	240
1500	270	1500	270
1750	300	1750	300
2000	325	2000	325
2500	380	2500	380
3000	435	3000	435
4000	525	4000	525
5000	600	5000	600
6000	650	6000	650
7000	700	7000	700
8000	730	8000	730
9000	760	9000	760
10,000	790	10,000	790

**TABLE A-2 Table of estimating demand**

Table 9.10 Estimated Hot Water Demand

Building Type	Hot Water <sup>a</sup> per Person, gal/day	Maximum Hourly Demand, Portion of Daily Use, gal	Duration of Peak Load, hr	Storage Capacity, Portion of Daily Use, gal	Heating Capacity Portion of Daily Use, gph
Residences, apartments, hotels <sup>b</sup>	20-40	1/7	4	1/5	1/7
Office buildings	2-3	1/5	2	1/5	1/6
Factory buildings	5	1/3	1	2/5	1/8

<sup>a</sup>at 140°F.

<sup>b</sup>Allow additional 15 gal per dishwasher and 40 gal per domestic clothes washer.

Source. From Ramsey and Sleeper, *Architectural Graphic Standards*, 8th ed., 1989, reprinted by permission of John Wiley & Sons.

TABLE A-3 Estimated hot water demand

Table 10.11 Capacity of Septic Tanks<sup>a</sup>

Single Family Dwellings, Number of Bedrooms	Multiple Dwelling Units or Apartments—One Bedroom Each, Number of Units	Other Uses, Maximum Fixture Units Served	Minimum Septic Tank Capacity in gal
1-3		20	1000
4	2	25	1200
5 or 6	3	33	1500
7 or 8	4	45	2000
	5	55	2250
	6	60	2500
	7	70	2750
	8	80	3000
	9	90	3250
	10	100	3500

TABLE A-4 Capacity of septic tanks

Friction Head Loss for Water in Commercial Steel Pipe (Schedule 40)

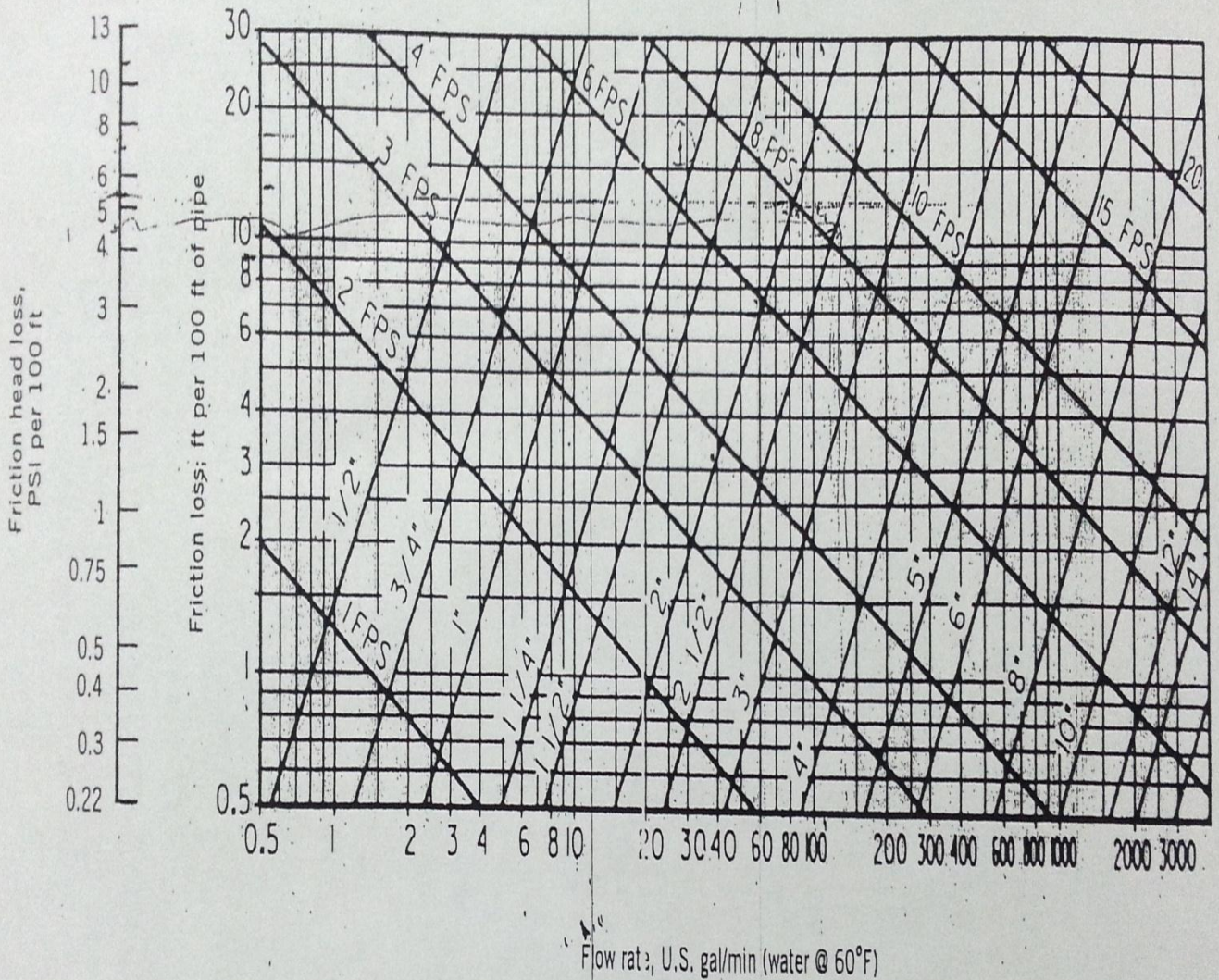

Figure 9.5 Chart of friction head loss in Schedule 40 black iron or steel pipe, for water at 60°F, in feet of water and psi per 100 ft of equivalent pipe length. Pipe sizes are nominal. (Reprinted by permission of the American Society of Heating, Refrigerating and Air-Conditioning Engineers, Atlanta, Georgia, from the 1993 ASHRAE Handbook - Fundamentals.)

Figure A-1 Chart of friction head loss

## 10-2. Specifications

### 1) Technical specifications

Model			AVXWNH022E*	AVXWNH028E*	AVXWNH036E*	AVXWNH056E*	AVXWNH071E*	
Power Supply		o/V/Hz	1/220-240/50	1/220-240/50	1/220-240/50	1/220-240/50	1/220-240/50	
Mode*1)			HP / HR	HP / HR	HP / HR	HP / HR	HP / HR	
Performance	Capacity	Cooling*2)	kW	2.2	2.8	3.6	5.6	6.8
			Btu/h	7,500	9,500	12,200	19,100	23,200
	Heating*3)	kW	2.5	3.2	4.0	6.3	7.0	
		Btu/h	8,500	10,900	13,600	21,400	23,800	
	Condensate (with High fan speed)		Liters/h	1.12	1.44	1.91	2.87	3.51
Power	Input	W	25	25	30	45	50	
	Running Current	A	0.16	0.16	0.18	0.27	0.30	
Sound Level	Sound Pressure (High/Low)*4)	dB(A)	32 / 23	32 / 23	36 / 23	40 / 30	41 / 30	
Fan	Type	-	Crossflow fan	Crossflow fan	Crossflow fan	Crossflow fan	Crossflow fan	
	Motor	Model	-	KSFD-18SX	KSFD-18SX	KSFD-18SX	YDK-045S42213-02	YDK-045S42213-02
		Type	-	Feedback SSR	Feedback SSR	Feedback SSR	Feedback SSR	Feedback SSR
	Output	W	23 <sup>5)</sup>	23 <sup>5)</sup>	23 <sup>5)</sup>	40 <sup>5)</sup>	40 <sup>5)</sup>	
Airflow Rate	Cooling (High)	m <sup>3</sup> /min	7.8	7.8	9.3	12.0	14.0	
	Heating (High)	m <sup>3</sup> /min	8.2	8.2	9.5	13.0	15.0	
Refrigerant	Type	-	R410A	R410A	R410A	R410A	R410A	
	Control Method	-	EEV (Optional)	EEV (Optional)	EEV (Optional)	EEV (Optional)	EEV (Optional)	
Temperature Control		-	Micom&Thermistors	Micom&Thermistors	Micom&Thermistors	Micom&Thermistors	Micom&Thermistors	
Safety Devices		-	Fuse	Fuse	Fuse	Fuse	Fuse	
Option Code		-	027602-1120FA	027602-1320FA	027602-15224D	026602-1A226F	026602-1C228F	
Piping Connections	Liquid (Flare)	ø, mm	6.35	6.35	6.35	6.35	9.52	
	Gas (Flare)	ø, mm	12.70	12.70	12.70	12.70	15.88	
	Drain	ø, mm	ID 18 hose	ID 18 hose	ID 18 hose	ID 18 hose	ID 18 hose	
Weight	Net Weight	kg	7.8	7.8	7.8	13.0	13.0	
	Shipping Weight	kg	9.4	9.4	9.4	16.0	16.0	
Dimensions	Net Dimensions (W x H x D)	mm	825x285x189	825x285x189	825x285x189	1,065x298x218	1,065x298x218	
	Shipping Dimensions (W x H x D)	mm	900x349x252	900x349x252	900x349x252	1,137x377x299	1,137x377x299	
Functions	Auto Restart	-	O	O	O	O	O	
	Auto Swing	-	O	O	O	O	O	
	Group/Individual Control	-	O	O	O	O	O	
	External Contact Control	-	O	O	O	O	O	
	Trouble Shooting by LED	-	O	O	O	O	O	
Standard Accessories	Installation Manual	-	O	O	O	O	O	
	Operation Manual	-	O	O	O	O	O	
	Pattern Sheet for Installation	-	X	X	X	X	X	
	Flexible Drain Hose	-	O	O	O	O	O	
	Filter / Safety Grille	-	Filter (Washable)	Filter (Washable)	Filter (Washable)	Filter (Washable)	Filter (Washable)	
	Wireless Remote Controller	-	ARH-465	ARH-465	ARH-465	ARH-465	ARH-465	
Optional Accessories	Wireless Remote Controller	-	MR-CH01	MR-CH01	MR-CH01	MR-CH01	MR-CH01	
	Wired Remote Controller	Multi function	-	MWR-WE00	MWR-WE00	MWR-WE00	MWR-WE00	MWR-WE00
		Premium	-	MWR-WS0*	MWR-WS0*	MWR-WS0*	MWR-WS0*	MWR-WS0*
		Standard	-	MWR-TH01	MWR-TH01	MWR-TH01	MWR-TH01	MWR-TH01
		Simplified	-	MWR-SH00	MWR-SH00	MWR-SH00	MWR-SH00	MWR-SH00
	External Contact Interface Module	-	MIM-B14	MIM-B14	MIM-B14	MIM-B14	MIM-B14	
EEV Kits		MXD, MEV Series	MXD, MEV Series	MXD, MEV Series	MXD, MEV Series	MXD, MEV Series		

**TABLE A-5 Technical Specifications of Neo Forte indoor unit**

# 10 Neo Forte

## 10-3. Capacity tables

### 1) Cooling

TC : Total Capacity(kW), SHC : Sensible Heat Capacity(kW)

Model	Outdoor temperature (°C, DB)	Indoor temperature (°C, WB)													
		20 (°C, DB) 14 (°C, WB)		23 (°C, DB) 16 (°C, WB)		26 (°C, DB) 18 (°C, WB)		27 (°C, DB) 19 (°C, WB)		28 (°C, DB) 20 (°C, WB)		30 (°C, DB) 22 (°C, WB)		32 (°C, DB) 24 (°C, WB)	
		TC	SHC	TC	SHC	TC	SHC	TC	SHC	TC	SHC	TC	SHC	TC	SHC
022	10	1.5	1.3	1.8	1.5	2.1	1.5	2.2	1.5	2.3	1.5	2.5	1.6	2.6	1.4
	12	1.5	1.3	1.8	1.5	2.1	1.5	2.2	1.5	2.3	1.5	2.5	1.6	2.6	1.4
	14	1.5	1.3	1.8	1.5	2.1	1.5	2.2	1.5	2.3	1.5	2.5	1.6	2.6	1.4
	16	1.5	1.3	1.8	1.5	2.1	1.5	2.2	1.5	2.3	1.5	2.4	1.5	2.6	1.4
	18	1.5	1.3	1.8	1.5	2.1	1.5	2.2	1.5	2.3	1.5	2.4	1.5	2.6	1.4
	20	1.5	1.3	1.8	1.5	2.1	1.5	2.2	1.5	2.3	1.5	2.4	1.5	2.6	1.4
	21	1.5	1.3	1.8	1.5	2.1	1.5	2.2	1.5	2.3	1.5	2.4	1.5	2.6	1.4
	23	1.5	1.3	1.8	1.5	2.1	1.5	2.2	1.5	2.3	1.5	2.4	1.5	2.6	1.4
	25	1.5	1.3	1.8	1.5	2.1	1.5	2.2	1.5	2.3	1.5	2.4	1.5	2.6	1.4
	27	1.5	1.3	1.8	1.5	2.1	1.5	2.2	1.5	2.3	1.5	2.4	1.5	2.6	1.4
	29	1.5	1.3	1.8	1.5	2.1	1.5	2.2	1.5	2.3	1.5	2.4	1.5	2.6	1.4
	31	1.5	1.3	1.8	1.5	2.1	1.5	2.2	1.5	2.3	1.5	2.4	1.5	2.6	1.4
	33	1.5	1.3	1.8	1.5	2.1	1.5	2.2	1.5	2.3	1.5	2.4	1.5	2.6	1.4
	35	1.5	1.3	1.8	1.5	2.1	1.5	2.2	1.5	2.3	1.5	2.4	1.5	2.6	1.4
	37	1.5	1.3	1.8	1.5	2.1	1.5	2.2	1.5	2.3	1.5	2.4	1.5	2.6	1.4
	39	1.5	1.3	1.8	1.5	2.1	1.5	2.2	1.5	2.3	1.5	2.4	1.5	2.5	1.3
42	1.5	1.3	1.8	1.5	2.1	1.5	2.1	1.4	2.2	1.7	2.3	1.4	2.4	1.2	
44	1.5	1.3	1.8	1.5	2.0	1.4	2.1	1.4	2.1	1.6	2.2	1.3	2.2	1.1	
028	10	1.9	1.6	2.3	1.8	2.6	2.0	2.8	1.9	2.9	1.9	3.1	1.9	3.4	1.9
	12	1.9	1.6	2.3	1.8	2.6	2.0	2.8	1.9	2.9	1.9	3.1	1.9	3.3	1.8
	14	1.9	1.6	2.3	1.8	2.6	2.0	2.8	1.9	2.9	1.9	3.1	1.9	3.3	1.8
	16	1.9	1.6	2.3	1.8	2.6	2.0	2.8	1.9	2.9	1.9	3.1	1.9	3.3	1.8
	18	1.9	1.6	2.3	1.8	2.6	2.0	2.8	1.9	2.9	1.9	3.1	1.9	3.3	1.8
	20	1.9	1.6	2.3	1.8	2.6	2.0	2.8	1.9	2.9	1.9	3.1	1.9	3.3	1.8
	21	1.9	1.6	2.3	1.8	2.6	2.0	2.8	1.9	2.9	1.9	3.1	1.9	3.3	1.8
	23	1.9	1.6	2.3	1.8	2.6	2.0	2.8	1.9	2.9	1.9	3.1	1.9	3.3	1.8
	25	1.9	1.6	2.3	1.8	2.6	2.0	2.8	1.9	2.9	1.9	3.1	1.9	3.3	1.8
	27	1.9	1.6	2.3	1.8	2.6	2.0	2.8	1.9	2.9	1.9	3.1	1.9	3.3	1.8
	29	1.9	1.6	2.3	1.8	2.6	2.0	2.8	1.9	2.9	1.9	3.1	1.9	3.3	1.8
	31	1.9	1.6	2.3	1.8	2.6	2.0	2.8	1.9	2.9	1.9	3.1	1.9	3.3	1.8
	33	1.9	1.6	2.3	1.8	2.6	2.0	2.8	1.9	2.9	1.9	3.1	1.9	3.3	1.8
	35	1.9	1.6	2.3	1.8	2.6	2.0	2.8	1.9	2.9	1.9	3.1	1.9	3.3	1.8
	37	1.9	1.6	2.3	1.8	2.6	2.0	2.8	1.9	2.9	1.9	3.1	1.9	3.3	1.8
	39	1.9	1.6	2.3	1.8	2.6	2.0	2.8	1.9	2.9	1.9	3.0	1.8	3.2	1.7
42	1.9	1.6	2.3	1.8	2.6	2.0	2.7	1.8	2.8	1.8	2.9	1.7	3.0	1.6	
44	1.9	1.6	2.3	1.8	2.5	1.9	2.7	1.8	2.7	1.7	2.7	1.6	2.8	1.5	
036	10	2.5	2.1	2.9	2.2	3.4	2.3	3.6	2.4	3.7	2.4	4.0	2.4	4.3	2.3
	12	2.5	2.1	2.9	2.2	3.4	2.3	3.6	2.4	3.7	2.4	4.0	2.4	4.3	2.3
	14	2.5	2.1	2.9	2.2	3.4	2.3	3.6	2.4	3.7	2.4	4.0	2.4	4.3	2.3
	16	2.5	2.1	2.9	2.2	3.4	2.3	3.6	2.4	3.7	2.4	4.0	2.4	4.3	2.3
	18	2.5	2.1	2.9	2.2	3.4	2.3	3.6	2.4	3.7	2.4	4.0	2.4	4.3	2.3
	20	2.5	2.1	2.9	2.2	3.4	2.3	3.6	2.4	3.7	2.4	4.0	2.4	4.2	2.3
	21	2.5	2.1	2.9	2.2	3.4	2.3	3.6	2.4	3.7	2.4	4.0	2.4	4.2	2.3
	23	2.5	2.1	2.9	2.2	3.4	2.3	3.6	2.4	3.7	2.4	4.0	2.4	4.2	2.3
	25	2.5	2.1	2.9	2.2	3.4	2.3	3.6	2.4	3.7	2.4	4.0	2.4	4.2	2.3
	27	2.5	2.1	2.9	2.2	3.4	2.3	3.6	2.4	3.7	2.4	4.0	2.4	4.2	2.3
	29	2.5	2.1	2.9	2.2	3.4	2.3	3.6	2.4	3.7	2.4	4.0	2.4	4.2	2.3
	31	2.5	2.1	2.9	2.2	3.4	2.3	3.6	2.4	3.7	2.4	4.0	2.4	4.2	2.3
	33	2.5	2.1	2.9	2.2	3.4	2.3	3.6	2.4	3.7	2.4	4.0	2.4	4.2	2.3
	35	2.5	2.1	2.9	2.2	3.4	2.3	3.6	2.4	3.7	2.4	4.0	2.4	4.2	2.3
	37	2.5	2.1	2.9	2.2	3.4	2.3	3.6	2.4	3.7	2.4	3.9	2.3	4.2	2.3
	39	2.5	2.1	2.9	2.2	3.4	2.3	3.6	2.4	3.7	2.4	3.9	2.3	4.1	2.2
42	2.5	2.1	2.9	2.2	3.4	2.3	3.5	2.3	3.6	2.3	3.7	2.2	3.9	2.1	
44	2.5	2.1	2.9	2.2	3.2	2.2	3.4	2.2	3.5	2.2	3.5	2.1	3.6	1.9	
056	10	3.9	3.0	4.6	3.4	5.3	3.7	5.6	3.8	5.8	3.8	6.3	3.9	6.7	3.6
	12	3.9	3.0	4.6	3.4	5.3	3.7	5.6	3.8	5.8	3.8	6.3	3.9	6.7	3.6
	14	3.9	3.0	4.6	3.4	5.3	3.7	5.6	3.8	5.8	3.8	6.2	3.8	6.7	3.6
	16	3.9	3.0	4.6	3.4	5.3	3.7	5.6	3.8	5.8	3.8	6.2	3.8	6.6	3.5
	18	3.9	3.0	4.6	3.4	5.3	3.7	5.6	3.8	5.8	3.8	6.2	3.8	6.6	3.5
	20	3.9	3.0	4.6	3.4	5.3	3.7	5.6	3.8	5.8	3.8	6.2	3.8	6.6	3.5
	21	3.9	3.0	4.6	3.4	5.3	3.7	5.6	3.8	5.8	3.8	6.2	3.8	6.6	3.5
	23	3.9	3.0	4.6	3.4	5.3	3.7	5.6	3.8	5.8	3.8	6.2	3.8	6.6	3.5
	25	3.9	3.0	4.6	3.4	5.3	3.7	5.6	3.8	5.8	3.8	6.2	3.8	6.6	3.5
	27	3.9	3.0	4.6	3.4	5.3	3.7	5.6	3.8	5.8	3.8	6.2	3.8	6.6	3.5
	29	3.9	3.0	4.6	3.4	5.3	3.7	5.6	3.8	5.8	3.8	6.2	3.8	6.6	3.5
	31	3.9	3.0	4.6	3.4	5.3	3.7	5.6	3.8	5.8	3.8	6.2	3.8	6.6	3.5
	33	3.9	3.0	4.6	3.4	5.3	3.7	5.6	3.8	5.8	3.8	6.2	3.8	6.6	3.5
	35	3.9	3.0	4.6	3.4	5.3	3.7	5.6	3.8	5.8	3.8	6.2	3.8	6.6	3.5
	37	3.9	3.0	4.6	3.4	5.3	3.7	5.6	3.8	5.8	3.8	6.1	3.7	6.5	3.4
	39	3.9	3.0	4.6	3.4	5.3	3.7	5.6	3.8	5.8	3.8	6.1	3.7	6.4	3.3
42	3.9	3.0	4.6	3.4	5.3	3.7	5.4	3.7	5.6	3.7	5.8	3.6	6.0	3.2	
44	3.9	3.0	4.6	3.4	5.0	3.6	5.3	3.6	5.4	3.6	5.5	3.5	5.6	3.0	
071	10	4.7	3.7	5.5	4.1	6.4	4.5	6.8	4.6	7.1	4.6	7.6	4.6	8.2	4.4
	12	4.7	3.7	5.5	4.1	6.4	4.5	6.8	4.6	7.1	4.6	7.6	4.6	8.1	4.3
	14	4.7	3.7	5.5	4.1	6.4	4.5	6.8	4.6	7.1	4.6	7.6	4.6	8.1	4.3
	16	4.7	3.7	5.5	4.1	6.4	4.5	6.8	4.6	7.1	4.6	7.6	4.6	8.1	4.3
	18	4.7	3.7	5.5	4.1	6.4	4.5	6.8	4.6	7.0	4.6	7.5	4.5	8.0	4.2
	20	4.7	3.7	5.5	4.1	6.4	4.5	6.8	4.6	7.0	4.6	7.5	4.5	8.0	4.2
	21	4.7	3.7	5.5	4.1	6.4	4.5	6.8	4.6	7.0	4.6	7.5	4.5	8.0	4.2
	23	4.7	3.7	5.5	4.1	6.4	4.5	6.8	4.6	7.0	4.6	7.5	4.5	8.0	4.2
	25	4.7	3.7	5.5	4.1	6.4	4.5	6.8	4.6	7.0	4.6	7.5	4.5	8.0	4.2
	27	4.7	3.7	5.5	4.1	6.4	4.5	6.8	4.6	7.0	4.6	7.5	4.5	8.0	4.2
	29	4.7	3.7	5.5	4.1	6.4	4.5	6.8	4.6	7.0	4.6	7.5	4.5	8.0	4.2
	31	4.7	3.7	5.5	4.1	6.4	4.5	6.8	4.6	7.0	4.6	7.5	4.5	8.0	4.2
	33	4.7	3.7	5.5	4.1	6.4	4.5	6.8	4.6	7.0	4.6	7.5	4.5	8.0	4.2
	35	4.7	3.7	5.5	4.1	6.4	4.5	6.8	4.6	7.0	4.6	7.5	4.5	8.0	4.2
	37	4.7	3.7	5.5	4.1	6.4	4.5	6.8	4.6	7.0	4.6	7.5	4.5	7.9	4.1
	39	4.7	3.7	5.5	4.1	6.4	4.5	6.8	4.6	7.0	4.6	7.4	4.4	7.7	4.0
42	4.7	3.7	5.5	4.1	6.4	4.5	6.6	4.5	6.7	4.4	7.0	4.2	7.3	3.8	
44	4.7	3.7	5.5	4.1	6.1	4.4	6.5	4.4	6.5	4.3	6.7	4.1	6.8	3.6	

TABLE A-6 Cooling capacity tables for Neo Forte indoor unit





2) Heating

TC : Total Capacity(kW)

Model	Outdoor temperature (°C)		Indoor temperature (°C, DB)				
			16.0	18.0	20.0	22.0	24.0
	DB	WB	TC kW	TC kW	TC kW	TC kW	TC kW
022	-20	-21	1.5	1.5	1.5	1.5	1.5
	-17	-18	1.6	1.6	1.6	1.6	1.6
	-15	-16	1.7	1.6	1.6	1.6	1.6
	-12	-13	1.8	1.8	1.8	1.8	1.7
	-10	-11	2.0	2.0	1.9	1.9	1.9
	-7	-8	2.3	2.2	2.2	2.0	2.0
	-5	-6	2.4	2.3	2.3	2.2	2.2
	-3	-4	2.5	2.5	2.4	2.3	2.2
	0	-1	2.6	2.5	2.5	2.3	2.2
	3	2.2	2.7	2.6	2.5	2.3	2.2
	5	4.1	2.8	2.7	2.5	2.3	2.2
	7	6	2.8	2.7	2.5	2.3	2.2
	9	7.9	3.0	2.7	2.5	2.3	2.2
	11	9.8	3.0	2.7	2.5	2.3	2.2
	13	12	3.0	2.7	2.5	2.3	2.2
15	14	3.0	2.7	2.5	2.3	2.2	
028	-20	-21	1.9	1.9	1.9	1.9	1.9
	-17	-18	2.0	2.0	2.0	2.0	1.9
	-15	-16	2.1	2.1	2.0	2.0	1.9
	-12	-13	2.2	2.2	2.2	2.1	2.1
	-10	-11	2.3	2.3	2.3	2.3	2.2
	-7	-8	2.5	2.4	2.4	2.4	2.3
	-5	-6	2.6	2.6	2.5	2.5	2.4
	-3	-4	2.8	2.7	2.7	2.6	2.5
	0	-1	2.9	2.8	2.8	2.7	2.6
	3	2.2	3.0	3.0	2.9	2.8	2.7
	5	4.1	3.2	3.1	3.1	2.9	2.7
	7	6	3.3	3.2	3.2	3.0	2.7
	9	7.9	3.4	3.3	3.2	3.0	2.7
	11	9.8	3.5	3.3	3.2	3.0	2.7
	13	12	3.6	3.4	3.2	3.0	2.7
15	14	3.7	3.4	3.2	3.0	2.7	
036	-20	-21	2.4	2.4	2.3	2.3	2.3
	-17	-18	2.6	2.5	2.4	2.4	2.3
	-15	-16	2.7	2.6	2.5	2.5	2.4
	-12	-13	2.8	2.7	2.7	2.6	2.6
	-10	-11	2.9	2.9	2.9	2.8	2.8
	-7	-8	3.1	3.1	3.0	3.0	2.9
	-5	-6	3.3	3.2	3.2	3.1	3.0
	-3	-4	3.4	3.4	3.3	3.2	3.1
	0	-1	3.6	3.6	3.5	3.4	3.2
	3	2.2	3.8	3.7	3.7	3.5	3.4
	5	4.1	3.9	3.9	3.8	3.6	3.4
	7	6	4.1	4.1	4.0	3.7	3.4
	9	7.9	4.2	4.1	4.0	3.7	3.4
	11	9.8	4.4	4.2	4.0	3.7	3.4
	13	12	4.5	4.2	4.0	3.7	3.4
15	14	4.6	4.3	4.0	3.7	3.4	
056	-20	-21	3.9	3.8	3.8	3.7	3.7
	-17	-18	4.0	4.0	3.9	3.8	3.8
	-15	-16	4.2	4.1	4.0	3.9	3.8
	-12	-13	4.4	4.3	4.2	4.2	4.1
	-10	-11	4.6	4.6	4.5	4.4	4.4
	-7	-8	4.9	4.8	4.8	4.7	4.5
	-5	-6	5.2	5.1	5.0	4.9	4.7
	-3	-4	5.4	5.3	5.3	5.1	4.9
	0	-1	5.7	5.6	5.5	5.3	5.0
	3	2.2	5.9	5.9	5.8	5.6	5.3
	5	4.1	6.2	6.1	6.0	5.7	5.3
	7	6	6.5	6.4	6.3	5.8	5.3
	9	7.9	6.7	6.5	6.3	5.8	5.3
	11	9.8	6.9	6.6	6.3	5.8	5.3
	13	12	7.1	6.7	6.3	5.8	5.3
15	14	7.3	6.8	6.3	5.8	5.3	
071	-20	-21	4.4	4.3	4.2	4.2	4.2
	-17	-18	4.5	4.4	4.3	4.3	4.2
	-15	-16	4.7	4.6	4.4	4.3	4.2
	-12	-13	4.9	4.8	4.7	4.6	4.5
	-10	-11	5.1	5.1	5.0	4.9	4.9
	-7	-8	5.4	5.4	5.3	5.2	5.1
	-5	-6	5.7	5.6	5.6	5.4	5.2
	-3	-4	6.0	5.9	5.9	5.6	5.4
	0	-1	6.3	6.2	6.1	5.9	5.6
	3	2.2	6.6	6.5	6.4	6.2	5.9
	5	4.1	6.9	6.8	6.7	6.3	5.9
	7	6	7.2	7.1	7.0	6.5	5.9
	9	7.9	7.4	7.2	7.0	6.5	5.9
	11	9.8	7.6	7.3	7.0	6.5	5.9
	13	12	7.9	7.4	7.0	6.5	5.9
15	14	8.1	7.5	7.0	6.5	5.9	

**TABLE A-7 Heating capacity tables for Neo Forte indoor unit**

## (2) Compact combinations

Type															
Model	Compact Combinations		18 HP		20 HP		22 HP								
	Basic	RXXVHT080GE	1												
		RXXVHT100GE	1		2		1								
		RXXVHT120GE					1								
		RXXVHT140GE													
	RXXVHT160GE														
Power Supply		αV/Hz	3/380-415/50		3/380-415/50		3/380-415/50								
Mode*1)		-	HP		HP		HP								
Performance	Horse Power		HP		18		20								
	Capacity	Cooling*2)	kW		50.4		56.0								
			Btu/h		171,900		191,000								
		Heating*3)	kW		56.7		63.0								
Btu/h			193,500		215,000										
Power	Nominal input	Cooling	kW		13.54		15.56								
		Heating	kW		12.67		14.32								
	Nominal running current	Cooling	A		26.1		27.8								
		Heating	A		25.0		26.0								
Circuit Breaker (MCCB/ELB)		A		50		60									
COP	Cooling		-		3.72		3.60								
	Heating		-		4.48		4.40								
Compressor	Model		-		ZPJ61*	ZPJ72*	ZPJ83*	ZPJ61*	ZPJ72*	ZPJ83*	ZPJ61*	ZPJ72*	ZPJ83*		
	Type		-		Digital scroll		Fixed scroll		Digital scroll		Fixed scroll		Digital scroll		
	Number		EA		2		2		2		2		1		
	Piston Displacement		cc/Rev		58.1		58.1		58.1		58.1		77.2		
	Output		kW		493		493		493		493		8.02		
	Lubricant	Type		-		3MAF POE		3MAF POE		3MAF POE		3MAF POE		3MAF POE	
		Charging		cc		1,880		1,880		1,880		1,880		1,990	
Fan	Type/Control		-		Propeller/BLDC		Propeller/BLDC		Propeller/BLDC		Propeller/BLDC		Propeller/BLDC		
	Motor Output		W												
	Airflow Rate		m³/min		170 x 2		170 x 2		170 x 2		170 x 1 + 180 x 1		170 x 1 + 180 x 1		
	External Static Pressure	Max.	mmAq		8		8		8		8		8		
Pa			78.5		78.5		78.5		78.5		78.5				
Safety Devices	Mechanical Type		-		High pressure switch		High pressure switch		High pressure switch		High pressure switch		High pressure switch		
			-		Crank Case Heater		Crank Case Heater		Crank Case Heater		Crank Case Heater		Crank Case Heater		
			-		Fuse for PCB		Fuse for PCB		Fuse for PCB		Fuse for PCB		Fuse for PCB		
	Electronic Type		-		Over voltage protection		Over voltage protection		Over voltage protection		Over voltage protection		Over voltage protection		
			-		Current Transformer		Current Transformer		Current Transformer		Current Transformer		Current Transformer		
		-		Fan over heat/current protector		Fan over heat/current protector		Fan over heat/current protector		Fan over heat/current protector		Fan over heat/current protector			
Piping Connections	Liquid		ø, mm		15.88		15.88		15.88		15.88		15.88		
	Gas		ø, mm		28.58		28.58		28.58		28.58		28.58		
	Oil (Flare)		ø, mm		6.35		6.35		6.35		6.35		6.35		
	Installation Limitation	Max. Length		m		200		200		200		200		200	
		Max. Height		m		50 (40)		50 (40)		50 (40)		50 (40)		50 (40)	
Refrigerant	Type		-		R410A		R410A		R410A		R410A		R410A		
	Factory Charging		kg		7.5 x 2		7.5 x 2		7.5 x 2		7.5 x 2		7.5 x 2		
Sound*4)	Sound Pressure		dB(A)		60		61		62		62		62		
Set Size	Net Weight		kg		240 x 2		240 x 2		240 x 2		240 x 2		240 x 2		
	Shipping Weight		kg		253 x 2		253 x 2		253 x 2		253 x 2		253 x 2		
	Net Dimensions (WxHxD)		mm		(880 x 1,703 x 765) x 2		(880 x 1,703 x 765) x 2		(880 x 1,703 x 765) x 2		(880 x 1,703 x 765) x 2		(880 x 1,703 x 765) x 2		
	Shipping Dimensions (WxHxD)		mm		(948 x 1,868 x 832) x 2		(948 x 1,868 x 832) x 2		(948 x 1,868 x 832) x 2		(948 x 1,868 x 832) x 2		(948 x 1,868 x 832) x 2		
Cable	Main Power (Below 50m)		mm²		CV 6		CV 10		CV 10		CV 10		CV 10		
	Communication		mm²		0.75~1.50		0.75~1.50		0.75~1.50		0.75~1.50		0.75~1.50		
Operating Temp. Range	Cooling		°C		-5~43		-5~43		-5~43		-5~43		-5~43		
	Heating		°C		-20~24		-20~24		-20~24		-20~24		-20~24		

**TABLE A-8 Technical specifications of outdoor unit**

## 7. Refrigerant piping works

### 4) Pipe selection

		Outdoor unit connection pipe size : (A1), (A2), (A3)		Branch joint : (D), (E), (F)																																																																																																																					
<p>12Hp 14Hp 16Hp</p> <p>(A1) (A1) (A1) (A2) (A3) (B) (C) (D) (E) (F)</p> <p>○ (A) ■ (B)</p> <p>※ Example) 42HP of compact combinations</p> <table border="1"> <thead> <tr> <th rowspan="2">HP</th> <th rowspan="2">Mark</th> <th colspan="2">Pipe size(O.D.mm)</th> </tr> <tr> <th>Liquid</th> <th>Gas</th> </tr> </thead> <tbody> <tr> <td>12 HP</td> <td>(A1)</td> <td>ø12.70</td> <td>ø25.40</td> </tr> <tr> <td>14 HP</td> <td>(A1)</td> <td>ø12.70</td> <td>ø25.40</td> </tr> <tr> <td>16 HP</td> <td>(A1)</td> <td>ø12.70</td> <td>ø28.58</td> </tr> <tr> <td>26 HP</td> <td>(A2)</td> <td>ø19.05</td> <td>ø31.75</td> </tr> <tr> <td>42 HP</td> <td>(A3)</td> <td>ø19.05</td> <td>ø38.10</td> </tr> </tbody> </table>		HP	Mark	Pipe size(O.D.mm)		Liquid	Gas	12 HP	(A1)	ø12.70	ø25.40	14 HP	(A1)	ø12.70	ø25.40	16 HP	(A1)	ø12.70	ø28.58	26 HP	(A2)	ø19.05	ø31.75	42 HP	(A3)	ø19.05	ø38.10	<p>A1 : Select the pipes according to the outdoor unit capacity with following table.</p> <p>A2 : Select the pipes according to sum of outdoor unit capacities behind the outdoor joint with following table.</p> <p>A3 : Select the main pipe of outdoor units with the following table.</p> <table border="1"> <thead> <tr> <th rowspan="2">Outdoor unit</th> <th colspan="2">Pipe size (O.D. mm)</th> <th rowspan="2">Oil balancing pipe size</th> </tr> <tr> <th>Liquid</th> <th>Gas</th> </tr> </thead> <tbody> <tr> <td>8HP</td> <td rowspan="2">ø9.52</td> <td>ø19.05</td> <td rowspan="10">ø6.35</td> </tr> <tr> <td>10HP</td> <td>ø22.23</td> </tr> <tr> <td>12HP</td> <td rowspan="3">ø12.70</td> <td>ø25.40</td> </tr> <tr> <td>14HP</td> <td>ø28.58</td> </tr> <tr> <td>16HP</td> <td>ø31.75</td> </tr> <tr> <td>18HP</td> <td rowspan="3">ø15.88</td> <td>ø28.58</td> </tr> <tr> <td>20HP</td> <td>ø31.75</td> </tr> <tr> <td>22HP</td> <td>ø38.10</td> </tr> <tr> <td>24HP</td> <td rowspan="3">ø19.05</td> <td>ø31.75</td> </tr> <tr> <td>26~30HP</td> <td>ø38.10</td> </tr> <tr> <td>32~34HP</td> <td>ø44.45</td> </tr> <tr> <td>36~48HP</td> <td rowspan="2">ø22.23</td> <td>ø44.45</td> </tr> <tr> <td>50~64HP</td> <td>ø44.45</td> </tr> </tbody> </table> <p>*A1 : Pipes to the outdoor unit (Liquid, Gas) *A2 : Pipes between outdoor joint kits (Liquid, Gas) *A3 : Main pipes (Liquid, Gas)</p>		Outdoor unit	Pipe size (O.D. mm)		Oil balancing pipe size	Liquid	Gas	8HP	ø9.52	ø19.05	ø6.35	10HP	ø22.23	12HP	ø12.70	ø25.40	14HP	ø28.58	16HP	ø31.75	18HP	ø15.88	ø28.58	20HP	ø31.75	22HP	ø38.10	24HP	ø19.05	ø31.75	26~30HP	ø38.10	32~34HP	ø44.45	36~48HP	ø22.23	ø44.45	50~64HP	ø44.45	<p>■ <b>Branch joint of outdoor unit's multi connection (D)</b></p> <table border="1"> <thead> <tr> <th rowspan="2">Outdoor multi connection branch joint (D)</th> <th>Model</th> <th>Capacity of outdoor</th> </tr> </thead> <tbody> <tr> <td>MXJ-T3819K</td> <td>Below 48 HP</td> </tr> <tr> <td>MXJ-T4422K</td> <td>Above 50 HP</td> </tr> </tbody> </table> <p>■ <b>First branch joint (E)</b></p> <p>Select branch joint according to the outdoor unit's capacity</p> <table border="1"> <thead> <tr> <th rowspan="6">Y-joint (E)</th> <th>Outdoor unit</th> <th>Model</th> </tr> </thead> <tbody> <tr> <td>8, 10, 12, 14 HP</td> <td>MXJ-YA2512K</td> </tr> <tr> <td>16 HP</td> <td>MXJ-YA2812K</td> </tr> <tr> <td>18, 20, 22, 24HP</td> <td>MXJ-YA2815K</td> </tr> <tr> <td>26, 28, 30, 32, 34HP</td> <td>MXJ-YA3119K</td> </tr> <tr> <td>36, 28, 40, 42, 44, 46, 48HP</td> <td>MXJ-YA3819K</td> </tr> <tr> <td>50HP~</td> <td>MXJ-YA4422K</td> </tr> </tbody> </table> <p>■ <b>Branch joint (F)</b></p> <p>Select the pipe size according to the capacity sum of indoor units which are connected below this pipe.</p> <p>1) Y-joint</p> <table border="1"> <thead> <tr> <th rowspan="7">Y-joint (F)</th> <th>Model</th> <th>Total indoor unit' capacity</th> </tr> </thead> <tbody> <tr> <td>MXJ-YA1509K</td> <td>15.0 kW and below</td> </tr> <tr> <td>MXJ-YA2512K</td> <td>Over 15.0~40.6 kW and below</td> </tr> <tr> <td>MXJ-YA2812K</td> <td>Over 40.6~46.4 kW and below</td> </tr> <tr> <td>MXJ-YA2815K</td> <td>Over 46.4~69.6 kW and below</td> </tr> <tr> <td>MXJ-YA3119K</td> <td>Over 69.6~98.6 kW and below</td> </tr> <tr> <td>MXJ-YA3819K</td> <td>Over 98.6~139.2 kW and below</td> </tr> <tr> <td>MXJ-YA4422K</td> <td>Over 139.2 kW</td> </tr> </tbody> </table> <p>2) Header joint</p> <table border="1"> <thead> <tr> <th rowspan="3">Header joint (F)</th> <th>Model</th> <th>Total Indoor unit's capacity</th> <th>The connectable quantity of indoor units</th> </tr> </thead> <tbody> <tr> <td>MXJ-HA2512K</td> <td>46.4 kW and below</td> <td>4</td> </tr> <tr> <td>MXJ-HA3115K</td> <td>Over 46.4kW ~ 69.6 kW</td> <td>8</td> </tr> <tr> <td>MXJ-HA3819K</td> <td>Over 69.6 kW</td> <td>8</td> </tr> </tbody> </table>		Outdoor multi connection branch joint (D)	Model	Capacity of outdoor	MXJ-T3819K	Below 48 HP	MXJ-T4422K	Above 50 HP	Y-joint (E)	Outdoor unit	Model	8, 10, 12, 14 HP	MXJ-YA2512K	16 HP	MXJ-YA2812K	18, 20, 22, 24HP	MXJ-YA2815K	26, 28, 30, 32, 34HP	MXJ-YA3119K	36, 28, 40, 42, 44, 46, 48HP	MXJ-YA3819K	50HP~	MXJ-YA4422K	Y-joint (F)	Model	Total indoor unit' capacity	MXJ-YA1509K	15.0 kW and below	MXJ-YA2512K	Over 15.0~40.6 kW and below	MXJ-YA2812K	Over 40.6~46.4 kW and below	MXJ-YA2815K	Over 46.4~69.6 kW and below	MXJ-YA3119K	Over 69.6~98.6 kW and below	MXJ-YA3819K	Over 98.6~139.2 kW and below	MXJ-YA4422K	Over 139.2 kW	Header joint (F)	Model	Total Indoor unit's capacity	The connectable quantity of indoor units	MXJ-HA2512K	46.4 kW and below	4	MXJ-HA3115K	Over 46.4kW ~ 69.6 kW	8	MXJ-HA3819K	Over 69.6 kW	8
HP	Mark			Pipe size(O.D.mm)																																																																																																																					
		Liquid	Gas																																																																																																																						
12 HP	(A1)	ø12.70	ø25.40																																																																																																																						
14 HP	(A1)	ø12.70	ø25.40																																																																																																																						
16 HP	(A1)	ø12.70	ø28.58																																																																																																																						
26 HP	(A2)	ø19.05	ø31.75																																																																																																																						
42 HP	(A3)	ø19.05	ø38.10																																																																																																																						
Outdoor unit	Pipe size (O.D. mm)		Oil balancing pipe size																																																																																																																						
	Liquid	Gas																																																																																																																							
8HP	ø9.52	ø19.05	ø6.35																																																																																																																						
10HP		ø22.23																																																																																																																							
12HP	ø12.70	ø25.40																																																																																																																							
14HP		ø28.58																																																																																																																							
16HP		ø31.75																																																																																																																							
18HP	ø15.88	ø28.58																																																																																																																							
20HP		ø31.75																																																																																																																							
22HP		ø38.10																																																																																																																							
24HP	ø19.05	ø31.75																																																																																																																							
26~30HP		ø38.10																																																																																																																							
32~34HP		ø44.45																																																																																																																							
36~48HP	ø22.23	ø44.45																																																																																																																							
50~64HP		ø44.45																																																																																																																							
Outdoor multi connection branch joint (D)	Model	Capacity of outdoor																																																																																																																							
	MXJ-T3819K	Below 48 HP																																																																																																																							
MXJ-T4422K	Above 50 HP																																																																																																																								
Y-joint (E)	Outdoor unit	Model																																																																																																																							
	8, 10, 12, 14 HP	MXJ-YA2512K																																																																																																																							
	16 HP	MXJ-YA2812K																																																																																																																							
	18, 20, 22, 24HP	MXJ-YA2815K																																																																																																																							
	26, 28, 30, 32, 34HP	MXJ-YA3119K																																																																																																																							
	36, 28, 40, 42, 44, 46, 48HP	MXJ-YA3819K																																																																																																																							
50HP~	MXJ-YA4422K																																																																																																																								
Y-joint (F)	Model	Total indoor unit' capacity																																																																																																																							
	MXJ-YA1509K	15.0 kW and below																																																																																																																							
	MXJ-YA2512K	Over 15.0~40.6 kW and below																																																																																																																							
	MXJ-YA2812K	Over 40.6~46.4 kW and below																																																																																																																							
	MXJ-YA2815K	Over 46.4~69.6 kW and below																																																																																																																							
	MXJ-YA3119K	Over 69.6~98.6 kW and below																																																																																																																							
	MXJ-YA3819K	Over 98.6~139.2 kW and below																																																																																																																							
MXJ-YA4422K	Over 139.2 kW																																																																																																																								
Header joint (F)	Model	Total Indoor unit's capacity	The connectable quantity of indoor units																																																																																																																						
	MXJ-HA2512K	46.4 kW and below	4																																																																																																																						
	MXJ-HA3115K	Over 46.4kW ~ 69.6 kW	8																																																																																																																						
MXJ-HA3819K	Over 69.6 kW	8																																																																																																																							
		<p>Pipe size between branch joints : (B)</p> <p>Select the pipe size according to the capacity sum of indoor units which are connected below this pipe.</p> <table border="1"> <thead> <tr> <th rowspan="2">Total Indoor unit's capacity</th> <th colspan="2">Pipe size (O. D. mm)</th> </tr> <tr> <th>Liquid pipe</th> <th>Gas pipe</th> </tr> </thead> <tbody> <tr> <td>15.0 kW and below</td> <td rowspan="3">ø9.52</td> <td>ø15.88</td> </tr> <tr> <td>Over 15.0~23.2 kW and below</td> <td>ø19.05</td> </tr> <tr> <td>Over 23.2~29.0 kW and below</td> <td>ø22.23</td> </tr> <tr> <td>Over 29.0~40.6 kW and below</td> <td rowspan="2">ø12.70</td> <td>ø25.40</td> </tr> <tr> <td>Over 40.6~46.4 kW and below</td> <td>ø28.58</td> </tr> <tr> <td>Over 46.4~69.6 kW and below</td> <td>ø15.88</td> <td>ø28.58</td> </tr> <tr> <td>Over 69.6~98.6 kW and below</td> <td rowspan="2">ø19.05</td> <td>ø31.75</td> </tr> <tr> <td>Over 98.6~139.2 kW and below</td> <td>ø38.10</td> </tr> <tr> <td>Over 139.2 kW</td> <td>ø22.23</td> <td>ø44.45</td> </tr> </tbody> </table>		Total Indoor unit's capacity	Pipe size (O. D. mm)		Liquid pipe	Gas pipe	15.0 kW and below	ø9.52	ø15.88	Over 15.0~23.2 kW and below	ø19.05	Over 23.2~29.0 kW and below	ø22.23	Over 29.0~40.6 kW and below	ø12.70	ø25.40	Over 40.6~46.4 kW and below	ø28.58	Over 46.4~69.6 kW and below	ø15.88	ø28.58	Over 69.6~98.6 kW and below	ø19.05	ø31.75	Over 98.6~139.2 kW and below	ø38.10	Over 139.2 kW	ø22.23	ø44.45																																																																																										
Total Indoor unit's capacity	Pipe size (O. D. mm)																																																																																																																								
	Liquid pipe	Gas pipe																																																																																																																							
15.0 kW and below	ø9.52	ø15.88																																																																																																																							
Over 15.0~23.2 kW and below		ø19.05																																																																																																																							
Over 23.2~29.0 kW and below		ø22.23																																																																																																																							
Over 29.0~40.6 kW and below	ø12.70	ø25.40																																																																																																																							
Over 40.6~46.4 kW and below		ø28.58																																																																																																																							
Over 46.4~69.6 kW and below	ø15.88	ø28.58																																																																																																																							
Over 69.6~98.6 kW and below	ø19.05	ø31.75																																																																																																																							
Over 98.6~139.2 kW and below		ø38.10																																																																																																																							
Over 139.2 kW	ø22.23	ø44.45																																																																																																																							
		<p>Pipe size between branch joints and indoor unit (C)</p> <p>Select the pipe size according to the indoor's capacity.</p> <table border="1"> <thead> <tr> <th rowspan="2">Indoor unit's capacity</th> <th colspan="2">Pipe size (O.D. mm)</th> </tr> <tr> <th>Liquid pipe</th> <th>Gas pipe</th> </tr> </thead> <tbody> <tr> <td>2.2~5.6 kW</td> <td>ø6.35</td> <td>ø12.70</td> </tr> <tr> <td>7.1~14.0 kW</td> <td>ø9.52</td> <td>ø15.88</td> </tr> </tbody> </table>		Indoor unit's capacity	Pipe size (O.D. mm)		Liquid pipe	Gas pipe	2.2~5.6 kW	ø6.35	ø12.70	7.1~14.0 kW	ø9.52	ø15.88																																																																																																											
Indoor unit's capacity	Pipe size (O.D. mm)																																																																																																																								
	Liquid pipe	Gas pipe																																																																																																																							
2.2~5.6 kW	ø6.35	ø12.70																																																																																																																							
7.1~14.0 kW	ø9.52	ø15.88																																																																																																																							

TABLE A-9 Table of Refrigerant piping works

# **APPENDIX – B**