

بسم الله الرحمن الرحيم



Palestine Polytechnic University

School of Engineering

Electrical Engineering Department

Project

Rehabilitation of the electric power distribution

Grid in Taffouh town

By

Hamza H. khamayshe

&

Baraa A. Taradeh

Supervisor

Dr. Raed A .Amro

**Submitted to the College of Engineering
in partial fulfillment of the requirements for the
Bachelor degree in Electrical Power Engineering**

Hebron, May 2017

بطاقة الشكر

في مثل هذه اللحظات يتوقف اليراع ليفكر قبل أن يخط الحروف ليجمعها في كلمات ... تتبعثر
الأحرف وعبثاً أن يحاول تجميعها في سطور
سطوراً كثيرة تمر في الخيال ولا يبقى لنا في نهاية المطاف إلا قليلاً من الذكريات وصور تجمعنا برفاق
كانوا إلى جانبنا

فواجب علينا شكرهم ووداعهم ونحن نخطو خطواتنا الأولى في غمار الحياة
ونخص بالجزيل الشكر والعرفان إلى كل من أشعل شمعة في دروب عملنا و
وإلى من وقف على المنابر وأعطى من حصيلة فكره لينير دربنا
إلى الأساتذة الكرام في كلية الهندسة الكهربائية وتتوجه بالشكر الجزيل إلى

الدكتور رائد عمرو

الذي تفضل بإشراف على هذا البحث فجزاه الله عنا كل خير فله منا كل التقدير والاحترام ..

الإهداء

بِسْمِ اللَّهِ الرَّحْمَنِ الرَّحِيمِ

(قل إعملوا فسيرى الله عملكم ورسوله والمؤمنون)

صدق الله العظيم

إلهي لا يطيب الليل إلا بشكرك ولا يطيب النهار إلا بطاعتك .. ولا تطيب اللحظات إلا بذكرك .. ولا تطيب الآخرة إلا بعفوك .. ولا تطيب الجنة إلا برويتك

الله ﷻ

إلى من بلغ الرسالة وأدى الأمانة .. ونصح الأمة .. إلى نبي الرحمة ونور العالمين ..

سيدنا محمد ﷺ

إلى من كلله الله بالهبة والوقار .. إلى من علمني العطاء بدون انتظار .. إلى من أحمل أسمه بكل افتخار .. أرجو من الله أن يمد في عمرك لتري ثماراً قد حان قطافها بعد طول انتظار وستبقى كلماتك نجوم أهتدي بها اليوم وفي الغد وإلى الأبد ..

والذي العزيز

إلى ملاكي في الحياة .. إلى معنى الحب وإلى معنى الحنان والتفاني .. إلى بسمة الحياة وسر الوجود

إلى من كان دعائها سر نجاحي وحنانها بلسم جراحي إلى أعلى الجباب

أمي الحبيبة

إلى من بها أكبر وعليه أعتمد .. إلى شمعة متقدة تنير ظلمة حياتي ..

إلى من بوجودها أكتسب قوة ومحبة لا حدود لها ..

إلى من عرفت معها معنى الحياة

أختي

إلى أخي ورفيق دربي وهذه الحياة بدونك لاشيء معك أكون أنا وبدونك أكون مثل أي شيء .. في نهاية مشواري أريد أن أشكرك على موافقتك النبيلة إلى من تطلعت لنجاحي بنظرات الأمل

أخي

ABSTRACT

Electric Utilities seek to meet the power demand and reduce the losses of the electrical network while satisfying a number of constraints. During heavy loading conditions, so that the voltage variations around 10%. The power loss must also be kept as low as possible and a value around 10% or even less would be acceptable. Power system operators work hard to keep the system working around the nominal values to ensure proper functioning that ensures lower power loss and guarantees a continuity of service that is crucial to private and public sectors alike. This study investigates thoroughly the electrical distribution grid of the Taffouh Town where the electric grid in Taffouh town suffers from many problems technically and distribution suffered by the rest of the cities and villages of the West Bank That's after getting the information necessary to help rehabilitate this grid through the use several analytical programs and device, E-TAP software and Vega 78(power analyzer device). The suggested measures used for rehabilitation are the reactive power compensation using capacitor banks and replacement some of transformer and also the replacement of old wires and cables with new and adequate ones. The study will handle each of these measures collectively; The results obtained will be tabulated, graphed, analyzed, and compared with the values of the current situation. The results have shown that the distribution grid of Taffouh need to be rehabilitated ; Where the network power factor was improved from 0.868 to 0.97, thus reducing 58% of total losses in network and achieving economic feasibility of the project to provide 1018837.25 NIS / year; as a result of improved power factor which cost 33620 Nis for the entire project and reducing voltage drop from 64.99 % to 32.77% for an entire system; highest voltage drop 2.24% of the bus voltage in project after rehabilitation .

ملخص

تسعى المرافق الكهربائية إلى تلبية الطلب على الطاقة وتقليل خسائر الشبكة الكهربائية مع تلبية عدد من القيود. خلال ظروف التحميل الثقيلة، بحيث تكون اختلافات الجهد حوالي 10%. ويجب أيضا إبقاء فقدان الطاقة منخفضا قدر الإمكان في مدى حوالي 10% أو حتى أقل تكون مقبولة. نظام تشغيل الطاقة حول القيم الاسمية سيضمن الأداء السليم الذي يضمن فقدان طاقة أقل ويضمن استمرارية الخدمة التي تعتبر حاسمة للقطاعين العام والخاص على حد سواء. تدرس هذه الدراسة بشكل دقيق شبكة توزيع الكهرباء في بلدة تفوح؛ حيث تعاني الشبكة الكهربائية في قرية تفوح من العديد من المشاكل من الناحية الفنية والتوزيع لتي تعاني منها باقي مدن وقرى الضفة الغربية ذلك بعد الحصول على المعلومات اللازمة للمساعدة في إعادة تأهيل هذه الشبكة وذلك من خلال استخدام العديد من البرامج ولأجهزة، E-TAP و Vega78. التدابير المقترحة المستخدمة لإعادة التأهيل هي تعويض الطاقة الغير فعالة باستخدام وحدات المكثفات واستبدال بعض المحولات وأيضا استبدال الأسلاك القديمة والكابلات مع جديدة وكافية منها. وستتناول الدراسة كل من هذه التدابير مجتمعة؛ سيتم جدولة النتائج التي تم الحصول عليها، والرسوم البيانية، وتحليلها، ومقارنتها مع قيم الوضع الحالي. وأظهرت النتائج ضرورة إعادة تأهيل شبكة توزيع تفوح؛ حيث تم تحسين معامل قدرة الشبكة من 0.868 إلى 0.97، وبالتالي خفض 58% من إجمالي الخسائر في الشبكة وتحقيق الجدوى الاقتصادية للمشروع لتوفير 1018837.25 شيكل / سنة؛ نتيجة لتحسن معامل القدرة الذي تكلف 33620 شيكل للمشروع بأكمله وخفض انخفاض الجهد من 64.99% إلى 32.77% لنظام بأكمله؛ أي انه تكون اعلى نسبة خسارة في الجهد 2.24% بعد اعادة تأهيل الشبكة. للمشروع لتوفير 1018837.25 شيكل / سنة؛ نتيجة لتحسن معامل القدرة الذي تكلف 33620 شيكل للمشروع بأكمله وخفض انخفاض الجهد من 64.99% إلى 32.77% لنظام بأكمله؛ أي انه تكون اعلى نسبة خسارة في الجهد 2.24% بعد اعادة تأهيل الشبكة.

Table of Contents

Abstract	iii
ملخص	iv
Table of contentv
List of table	vi
List of figure.....	vii
Chapter One	1
1.1 Introduction.....	2
1.2 Feature of project.....	4
1.3 Objective.....	4
1.4 Time Schedule.....	5
Chapter Two.....	6
2.1 Taffouh electrical network.....	7
Chapter Three.....	16
3.1 Introduction.....	17
3.2 Various factors of electric loads.....	20
3.3 The properties of the transmission line.....	23
Chapter Four.....	27
4.1 Overview.....	28
4.2 Vega 78 power quality analyzer.....	28
4.3 Industrial Load.....	29
4.4 Power factor improvement.....	33
4.5 Feasibility study of capacitors.....	37
Chapter Five.....	43
5.1 E-TAP Program data.....	44
5.2 Domestic transformer load.....	45
5.3 Load growth of domestic load.....	47
5.4 Problems and recommendation.....	48

List of Tables

Table (1.1): Time Schedule.....	5
Table (2.1): Number and %impedance of distribution transformer.....	8
Table (2.2): ACSR size.....	13
Table (2.3): The resistance and reactance of the ACSR conductor.....	13
Table (2.4): Characteristic of XLPE Used.....	14
Table (4.1): Industrial consumption per month.....	30
Table (4.2): diversity Factors.....	31
Table (4.3): the industrial load and math calculation.....	32
Table (4.4): The requirement of capacitors to improve the power factor.....	36
Table (4.5): Capacitor bank price.....	38
Table (4.6): Contactor price.....	38
Table (4.7): Step device price.....	38
Table (4.8): LV 400 V Automatic Capacitor Bank Investments.....	39
Table (4.9): Network mode and consumption.....	41
Table (4.10): Total losses in network.....	41
Table (4.11): Total losses in network.....	41
Table (4.12): Penalties imposed of power factor.....	42
Table (5.1): The category of 19 domestic transformers, number of feeders and the region of transformer.....	46
Table (5.2): The population and energy demand in the last 10 year.....	47
Table (5.3): The load growth.....	47

List of Figures

Figure (1.1): Boundaries and the topography of the Taffouh town	3
Figure (1.2): Distribution of transmission lines on the town.....	3
Figure (2.1): most important component in network infrastructure.....	7
Figure (2.2): Distribution transformer.....	8
Figure (2.3): Autocloser switch.....	9
Figure (2.4): 33TDQSJ10 Expulsion Fuse & HRC fuse.....	10
Figure (2.5): Pin and Strain insulators.....	11
Figure (2.6): Surge arresters ISI-EGC33.....	11
Figure (2.7): Disconnecter switch outdoor.....	12
Figure (2.8): Overhead lines ASCR.....	12
Figure (2.9): XLPE power cable.....	14
Figure (2.10): Capacitor bank and plate name.....	15
Figure (3.1): Electric power system.....	17
Figure (3.2): Radial distribution system.....	18
Figure (3.3): Ring distribution system.....	19
Figure (3.4): Industrial and domestic consumption ratio.....	20
Figure (3.5): Represent one phase transmission line.....	23
Figure (3.6): Distance between conductors.....	25
Figure (3.7): Each connector capacity with the neutral line of three phases.....	25
Figure (4.1): Vega 78 power quality analyzer device.....	29
Figure (4.2): Monthly consumption of industrial load.....	30
Figure (4.3): Power triangle and power factor.....	33
Figure (4.4): Active and reactive power in the power distribution system without compensation.....	34
Figure (4.5): Active and reactive power in the power distribution system with correction.....	34
Figure (4.6): Automatic connection of capacitor with the transformer.....	37
Figure (4.7): delta capacitor bank connected in transformer.....	37
Figure (5.1): Systems that are built using ETAP.....	44
Figure (5.2): The ETAP interface.....	44
Figure (5.3): Population growth curve and the nearest mathematical equation to him	47
Figure (5.4): Isolator is not clean and dirty.....	49
Figure (5.5): transformers to rise from the earth, and is not suitable destination.....	50

Chapter One

Taffouh medium voltage network

1.1 Introduction.

1.2 Feature of the project.

1.3 Objective.

1.4 Schedule time.

1.1 Introduction :

Taffouh is a town lies west of Hebron as far 5km, It is connected to Hebron by a local asphalted road and it rises 850 m. above sea level .Its total population is approximately (14,000) The total area of the town is (20,300) Acres, but the building area is (628) Acres. Its master plan takes an elongated shape. As for the buildings, they are located on top of a mountainous hill separated by valleys of medium depth [1].

The electricity was reached Taffouh in nearly 1990 [1]. Taffouh electrical network is provided by Israel electrical company (IEC) through an overhead transmission line of 33 KV, with about 5MW, 152 ampere, Distributed to approximately 2500 domestic load and 16 industrial (privet) and a sum of non-privet industrial load connected in Municipality transformer[1] .

The Palestinian territories have no generating station, what we have is only a local network connected to the Israeli electricity corporation in individual connection points for each area.

The IEC supplies west bank by three (161) KV feeders to supply settlements, some Palestinian districts in the west bank are fed by (22) KV and others (33) KV feeders like Taffouh from the IEC, and some villages in depend on diesel generators to satisfy its need of electricity.

The main supply for electrical distribution network in main substation which located on Settlement Adorh away from the connecting point of the village, 4 km. And the voltage of the existing distribution networks is 33 KV. IEC supplies electricity to the electrified communities by 33 KV by overhead lines. Electricity is purchased from IEC and then distributed to the consumers. The existing network is local low voltage distributions networks connected to Israeli electrical corporation (IEC) ,and the main protective device is the Auto-Recloser which interconnect Taffouh network with ICE. The types of transmission lines that used are overhead lines and underground cables [1].

Taffouh has a good electricity network that covers most areas in the town. But due to the increasing population, the increasing numbers of beneficiaries, lack of craft men and a lack of electricity engineers, As a result there is a bad need to re-distribute and re-develop the network[1].

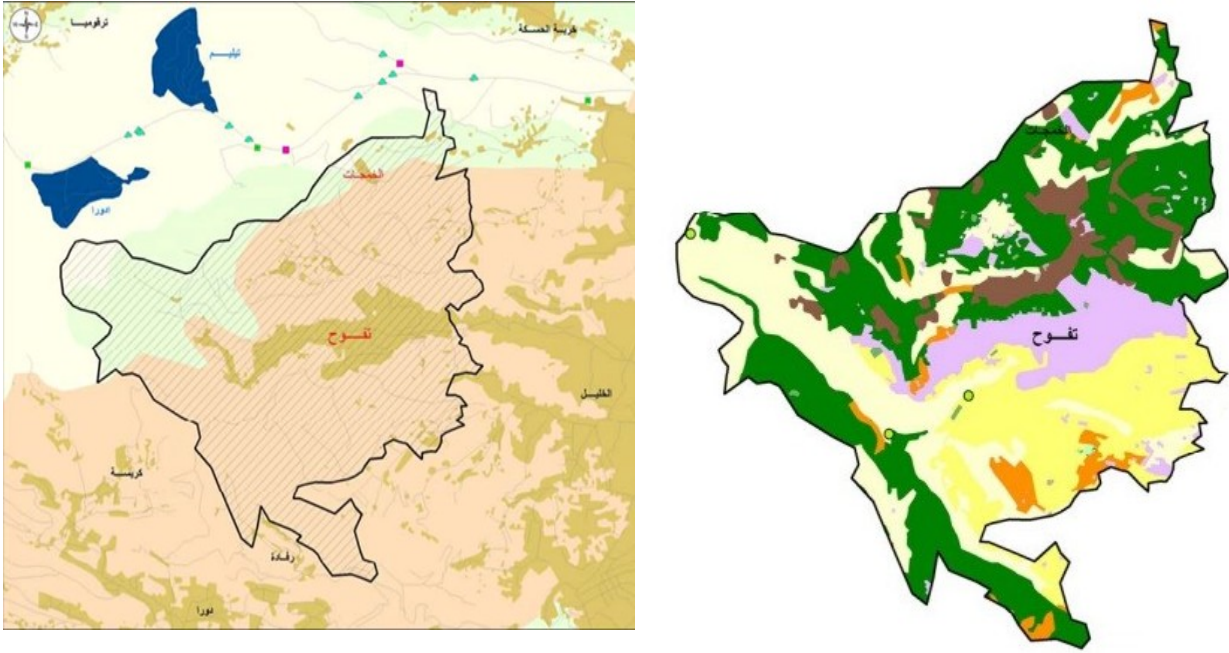

Fig.1.1 Boundaries and the topography of the Taffouh town .

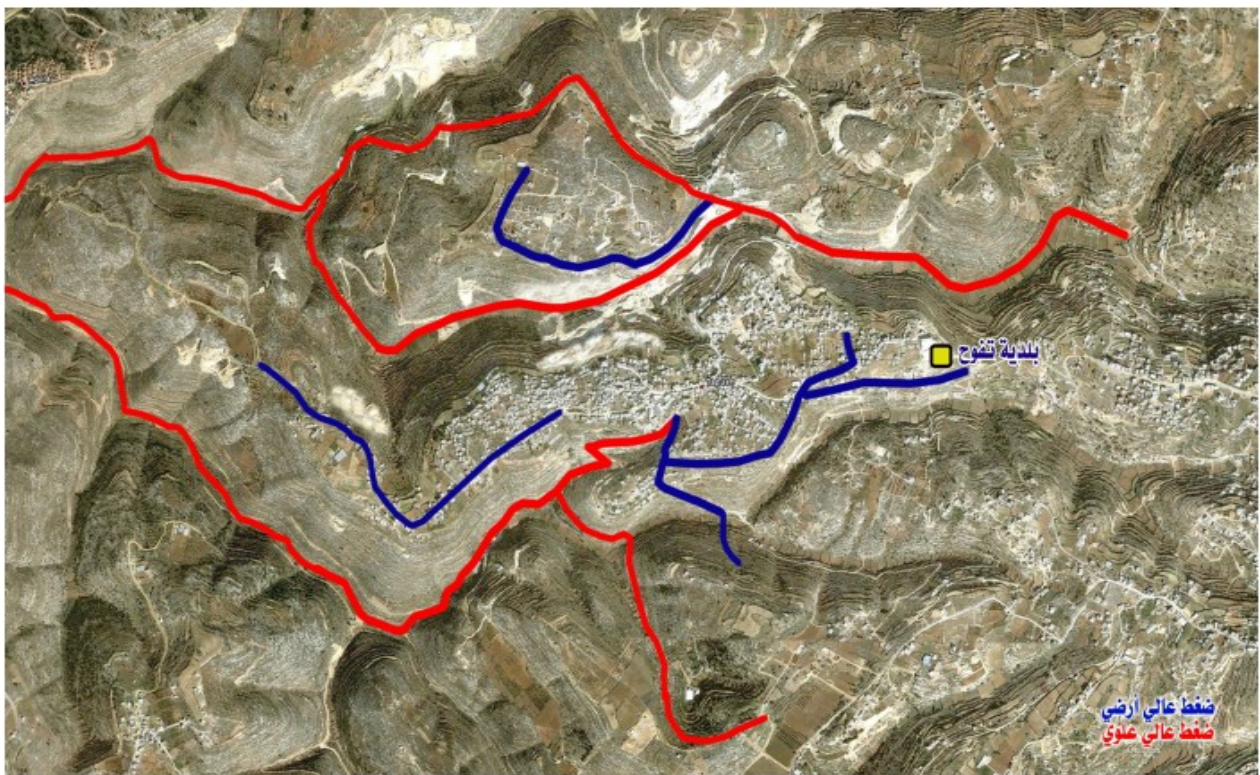

Fig. 1.2 Distribution of transmission lines on the town.



The electrical map of main transmission line, cable, transformer and tower in Taffouh town in appendix A2.

1.2 Feature of the project :

One of the main goals will be achieved in a project to rehabilitate the Taffouh network in the following points:

1. Provide the electricity in good quality to the consumer.
2. Reduce the losses of the kilowatt-hour.
3. Provide electricity to any place in taffouh.
4. Minims the possibilities of interruption of taffouh network.
5. Improve network construction in some areas of radial construction to construction ring .
6. Give tips to change some of the places transformers and Towers conductivity.
7. Give tips to use protection devices in some areas and the replacement of other devices.
8. Operational & planning reliability.

1.3 Objective:

In order to get the desired results of the project has to be the work of a good action plan, and the most important goals we will work with them on this project as follows:

1. Collecting data for network structure of all parameters and their specifications (location, transmission lines, transformer, load) .
2. Improving the voltage level and reducing the losses and correcting of power factor in the network; by modifying the current network model using ETAP program.
3. Forecast domestic load growth.
4. Making the system more protected by increasing reliability and stability.
5. Make required load calculation.
6. Analyzing the network under maximum load condition using load flow analyses using ETAP program.
7. To get economic benefit when improving the performance of network.

1.5 Time Schedule:

The proposed project is going to be implementing for two semesters as stated in table 1.1 .

Week	1	2	3	4	5	6	7	8	9	10	11	12	13	14	15	16	17	18	19	20	21	22	23	24	25	26	27	28	29	30	31
Mission																															
Choosing Project	█																														
Determine software		█																													
Data collection			█	█	█	█	█	█																							
data analysis							█	█	█	█	█	█	█																		
Field trips and draw a first form of network									█	█	█	█	█																		
The preparation of the final report of graduation project								█	█	█	█	█	█		█	█															
Amendment introduction of the project and the development of project tasks																█	█														
Taking readings using Vega																		█	█	█	█										
The development of network designs																					█	█	█	█	█	█					
Writing the final report and summary																						█	█	█	█	█	█	█	█	█	█

Chapter two

Taffouh electrical network

2.1 Taffouh electrical network.

2.1 Taffouh electrical network:

Electrical Network (infrastructure) is a set of interconnected structural elements that determine the effectiveness of the electrical Network system and the most important parts used in the network by which determine the reliability of the network construction, the Network components which used in Taffouh network are as follows:

1. Distribution transformer.
2. Autocloser switch.
3. Fuses.
4. Isolator.
5. Surge arresters.
6. 33KV Disconnecter switch outdoor.
7. Overhead lines ASCR.
8. Cable.
9. Capacitor bank.

Fig.2.1 shows a snap-shot of the most important component of the network .in appendix A the detailed topology is shown.

In the following specifications of the above component are described.

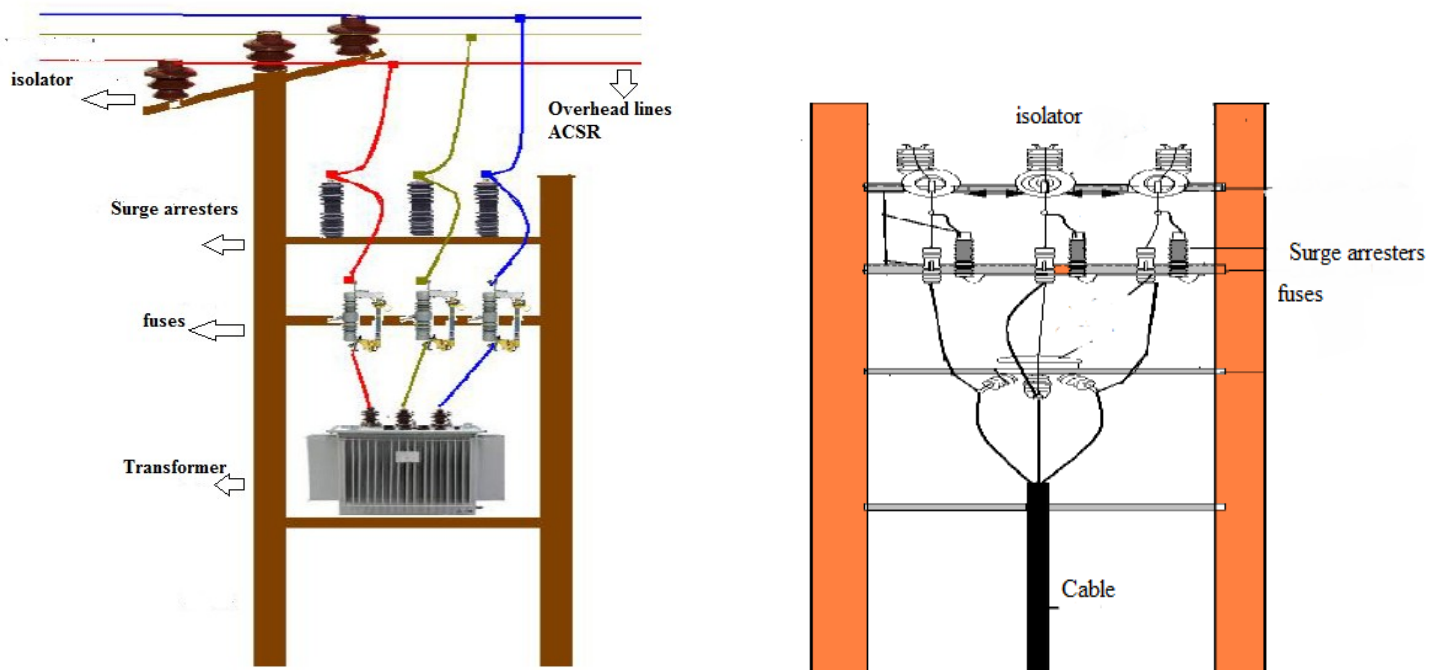

Fig.2.1: most important component in network infrastructure.

1) Distribution transformer :

Electrical transformer is more spread network elements and diverse forms and sizes and functions. The Taffouh network contain 35 transformer divided into 19 public and 16 industrial transformers (private) sorted into four types according to its capacities rated (150 – 630) KVA as shown in Table 2.1, the characteristics and classifications of transformers in the network as follows :

1. 3-phase Transformers.
2. Oil-immersed, self-oil-cooled.
3. Step-down 33 Δ /0.4 γ KV.
4. Very low frequency (50HZ) transformers.



Fig.2.2: distribution transformer

Table 2.1: Number and %impedance of distribution transformer.

Transformer rating KVA	Number of TR	Relative impedance%
630	9	4%
400	19	4%
250	5	4%
150	2	4%



For more details on electric transformers in Taffouh electrical network see Appendix A.

2) Autocloser switch :

Network containing just one Autocloser switch(GVR38) located on the main interconnected point, used as back –up protection.

The most important advantage performed by Autocloser :

1. It saves time and expenses as allowing re-current after a period of time.
2. It helps maintenance teams to locating failure and processed.

But the disadvantage of Autocloser:

1. Because existence of many failures in the overhead lines due to weather conditions This device will be take it out from the service.
2. Sometimes it remains turned off after three stages of the test; until it is restarted from the technicians.

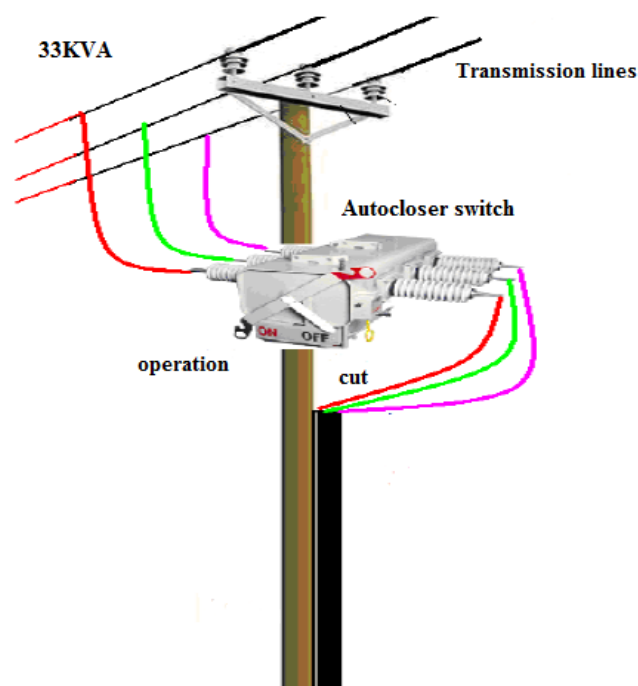

Fig .2.3: Autocloser switch.

3) Fuses :

Fuse used long ago as a simple electrical power systems protects against of short circuit and overload currents, It is the most commonly used protection devices to protect the modern electrical power systems for two reasons: The first reason is the cheap price and the second reason is It is that the fuse is more devices older where he can perform his job to the fullest after a period ranging from (15-20) years without the need for maintenance and because it does not contain moving parts. In the network used multiple types of fuses for the protection of various infrastructure devices of the most important Fuses is Drop out expulsion and High Rupturing Capacity (HRC) in order to protect transformers against short circuit and overload with different value depending in transformer current rated between [10-20]A and Condensator Capacitor Values ranging from[20-800]A .

For more details about the characteristic of fuses used in the network see [6].

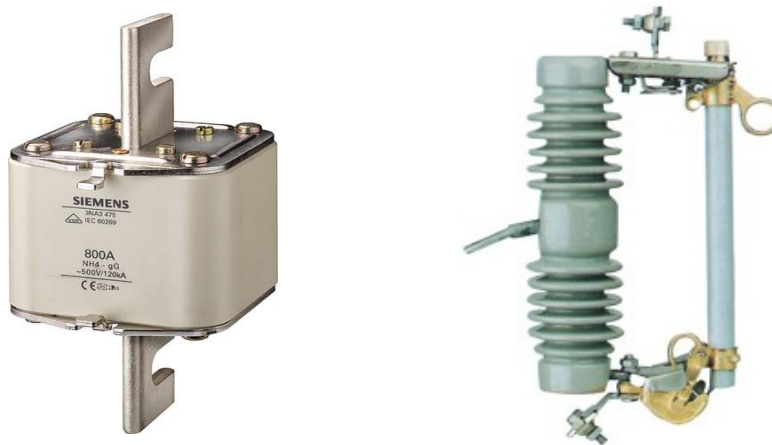

Fig .2.4: HRC fuse &33TDQSJ10 Expulsion Fuse.

4) Isolator:

The purpose of the use of insulator it is isolating connectors from the body of the column in order to prevent a short between conductors and others, as well as between conductors and the body of the Colum. Where the network contains many kinds of insulators such as the following:

1. Pin type Insulator.
2. Suspension type insulator.
3. Strain type insulator.
4. Line post insulator.



Fig .2.5: Pin and Strain insulators.

5) Surge arresters:

Surge arresters placed at the beginning and end of the transmission lines for medium voltage, and place to protect the transformer in order to discharging the electric charge of the Arrester and passed it to the ground through a wire (50)mm to protect the network. Most transformers in Taffouh network have a Surge arresters ISI-EGC33 & ISI-HEC33 model, to know the characteristics of model lightning rod go to the [2].



Fig .2.6: Surge arresters ISI-EGC33.

6) Disconnecter switch outdoor :

Disconnecter switch is used to ensure that an electrical circuit is completely de-energized for service or maintenance and in project network used single phase and three phases Disconnecter switch.



Fig .2.7: Disconnecter switch outdoor.

7) Overhead lines ASCR :

Aluminum Conductor Steel Reinforced (ACSR) is concentrically stranded conductor with one or more layers of hard drawn 1350-H19 aluminum wire on galvanized steel wire core use in taffouh network Ranging lengths of [0.3-4] km, where the use of several types and sizes in the network see Table2.2.



Fig.2.8: Overhead lines ASCR

Table 2.2: ACSR size.

Overhead lines type	Wire size
ACSR	(4x50 +2x25mm ²) ABC
ACSR	3*95+3*25 Aluminum
ACSR	4*25+4*120 Aluminum
ACSR	(4X95+2X25 mm ²) ABC

This type of wire used in the network for several reasons:

1. High Tensile strength.
2. Better sag properties.
3. Economic design.
4. Best suited for transmission lines with long spans.

In Taffouh network the total available HV transmission lines are about 13 Km (A.C.S.R.) distributed in all network. The resistance and reactance of the ACSR conductor in table 2.3.

Table 2.3: The resistance and reactance of the ACSR conductor .

ACSR CABLE	R(Ohms/Km)	X(Ohms/Km)
120mm ²	0.219	0.269
95mm ²	0.301	0.322
50mm ²	0.543	0.333

8) Cable:

Underground cables is considered the second method of transport power after overhead lines where cables are used in five different places in the town type of 33kv CU XLPE power cable and its characteristics in a table 2.4.[3]

Table 2.4: Characteristic of XLPE Used.

Nominal Conductor Area	Thickness of Insulation	Approx. Overall Diameter	Approx. Weight	Maximum conductor Resistance at 20° C	Maximum conductor Reactance At 20° C	Normal Current Rating (Ground)
Sq.mm	mm	mm	Kg/km	ohm/km	ohm/km	Amps
120mm ²	1.2	34.8	3740	0.153	0.196	363
150mm ²	1.4	38.5	4600	0.124	0.198	406

This type of cable Tolerant of temperature[90-250]c and Ranging in lengths of cable network [.3-1.5]km, used in special places for many reasons:

- Population density in places.
- In recreational places.
- In some industrial sites.



Fig .2.9: XLPE power cable.

9) Capacitor Bank:

A Capacitor bank is a group of several capacitors of the same rating or different rating that are connected in series or parallel with each other to store electrical energy. The resulting bank is then used to counteract or correct a power factor lag or phase shift in an alternating current (AC) power supply.

And contain Taffouh infrastructure on the seven industrial transformers containing capacitors bank to correct power factor, connected in parallel with each phase and protect with 3 fuses as shown in Fig. 2.10.

This type of capacitor bank made in Italy IEC60831 as shown in Fig2.10 . For more detail about type of capacitor bank go to [4].



Fig. 2.10 Capacitor bank and plate name.

Chapter Three

Electric power system and nature of load.

3.1 Introduction.

3.2 Various factors of electric loads.

3.3 The properties of the transmission line.

3.1 Introduction:

Electric power system consists of three main parts: power plants, transportation system, and the system of distribution and represent the costs of the distribution system of approximately 40% of the total costs of the system of power, which is high and may be unexpected to many workers in the electric power field, so you should give it more importance and attention at the design and establishment of distribution system design depends on the study of electrical loads to be provided with energy.

The components of the electric power system

1. The generating station (IEC).
2. The distribution system.
3. The transmission line.
4. The load.

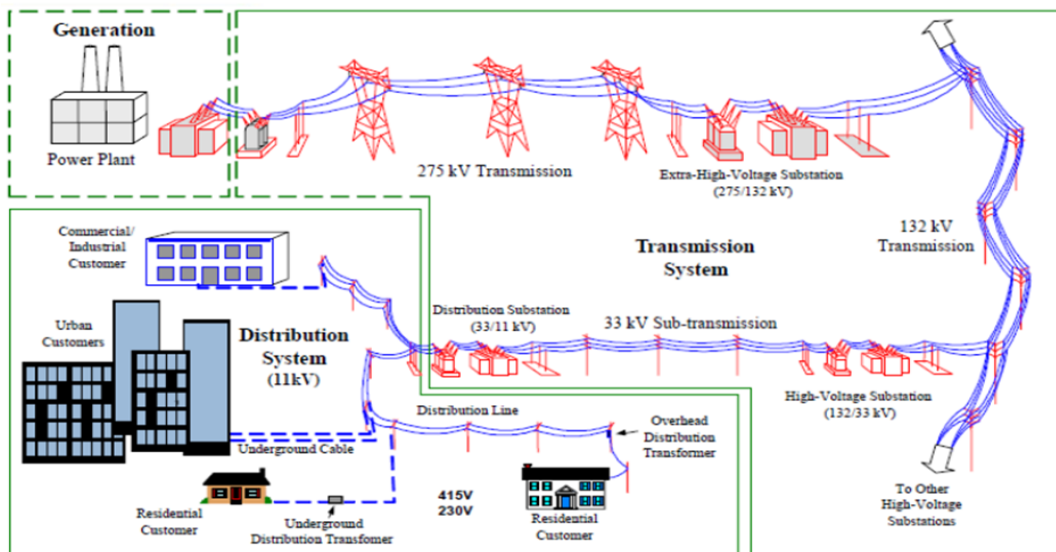

Fig 3.1: Electric power system.

1) Generating station (power supplier):

Generators are one of the essential components of power systems is the three phase ac generator known as synchronous generator.

Taffouh town network is provided by IEC through an overhead transmission line with about 5MVA if the consumption is more than 152A the IEC will trip the current.

The main supply transmission line pass through Farsh Al-hawa, and it away from the Israeli point of linkage 4 km, and the voltage level of the existing distribution network is 33KV.

2) Distribution system:

Electric power distribution is the final stage in the delivery of electric power; it carries electricity from the transmission system to individual consumers.

A distribution system may be classify according to:

- Nature of current: dc distribution systems or ac distribution systems.
- Type of construction: overhead system or underground system or mixture of them.
- Scheme of connection: radial system or ring system.

A) Radial distribution system

The energy flows from the source in radial form down to the consumers and in Taffouh network this type of distribution system .

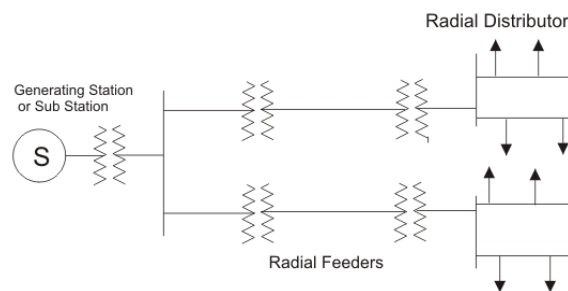

Fig.3.2: Radial distribution system.

Advantages:

Simple in design, realization and monitoring and control

Disadvantages:

- The consumers depend on a single distributor. Therefore, any fault on the distributor cuts off the consumers who are on the side of the fault away from the substation
- Increasing voltage drop on the lines/cables far from the source (Increased Transmission Losses). Therefore, Consumers at the distant end of the distributor are subjected to voltage fluctuations
- Low security of supply

B) Ring Distribution System:

The loop system provides better continuity of service than the radial system, with only short interruptions for switching. In the event of power failures due to faults on the line, the utility has only to find the fault and switch around it to restore service. The fault itself can then be repaired with a minimum of customer interruptions.

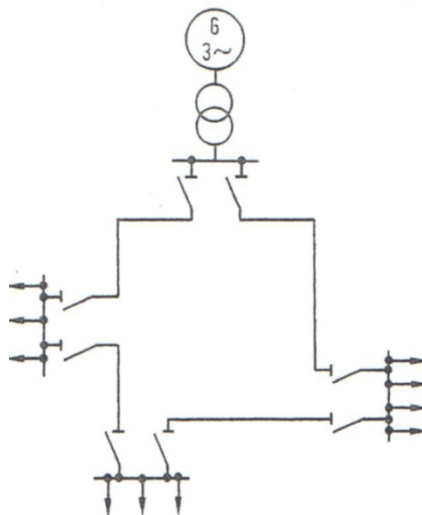

Fig.3.3: ring distribution system.

Advantages:

High security of supply

Disadvantages:

Expensive because of the large number of the required switches and conductors

3) Load:

It consists of both reactive and real power are specified and both voltage magnitude and angle are determined by the Vega 78 as part of solution. There are three types of loads in the network, industrial and commercial and domestic load. Which consume 11MW annually, where industrial loads consuming 3,946,504.00 kilowatts of total load in the network as it is shown in the Fig.3.4:

Different types of electrical load can be divided by distribution networks into three types:

- **Residential loads:** includes urban, suburban and rural are.
- **Commercial loads:** include airports, ports, hospitals, hotels and government buildings, theaters and stadiums.
- **Industrial Loads:** includes workshops and factories, small and large, quarries and crusher

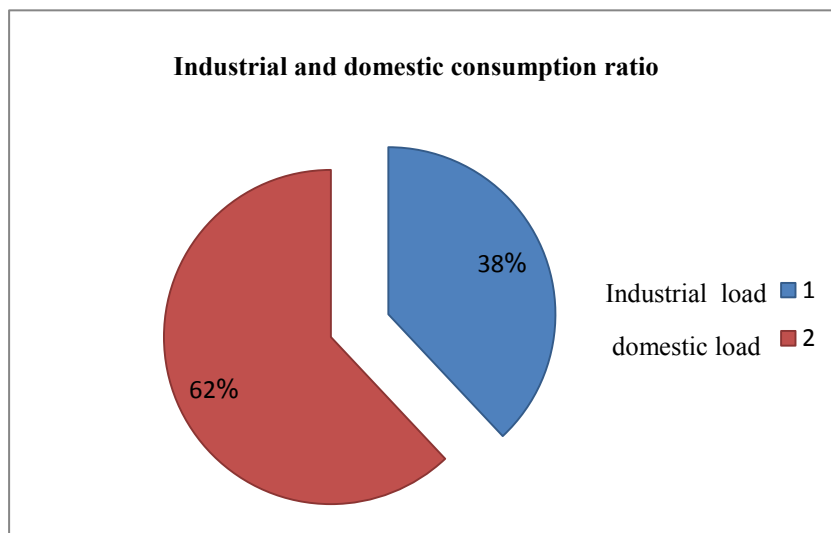

Fig. 3.4 Industrial and domestic consumption ratio .

3.2: Various Factors of electric loads:

1-Average load (demand)

It calculates the average load over a specified period of time, also known demand and be average unit load, an apparent power, as it includes the actual power regardless of the value of the power factor.

And the time period during which calculates the average value of load known dismissal time demand, when determining the average load also must specify the time period for this pressed.

$$\text{Average daily load} = \frac{\text{Total loads within 24 hours}}{24\text{h}}$$

$$\text{Average annual load} = \frac{\text{Total loads within 12 months}}{12\text{months}}$$

$$D_{\text{avg}} = \frac{\sum D_i}{\text{Time}} \quad (3.1)$$

2-Maximum demand (D_{max})

Demand maximum defined as the average demand for a time interval of between 15 and 30 minutes on the moment of load peak during the time period specified for the same order.

3-Demand factor (DF)

It is the ratio between the maximum demands of the system on the total loads connected to the system. This parameter is an indication of the total loads that operate at the same time.

$$\text{Demand coefficient} = \frac{\text{Demand maximum system}}{\text{Total loads connected to the system}}$$

$$DF = \frac{D_{\text{max}}}{\sum L_i} \quad (3.2)$$

4- Load Factor (F_{LD})

It is the ratio between the average load during a specific period of time and the maximum value load during the same period.

$$\text{Load Factor} = \frac{\text{Average load over a specified period of time}}{\text{The maximum value load during the same period}}$$

$$F_{LD} = \frac{D_{\text{av}}}{D_{\text{max}}} \quad (3.3)$$

5- Diversity Factor (F_{div})

It is the ratio between the total maximum demand each carrying loads and maximum demand for all loads.

$$\text{Diversity Factor} = \frac{\text{Total maximum demand for each load}}{\text{Demand for total maximum loads}}$$

$$F_{div} = \frac{\sum_{i=1}^n D_i \max}{D_t \max} \quad (3.4)$$

Where:

- $D_i \max$: Maximum demand for load D_i .
- $D_t \max$: Demand for total maximum demand D_t .
- Total demand: $D_t = D_1 + D_2 + \dots + D_i$.

6- Coincidence Factor (F_c)

It is opposite of diversity factor.

$$F_c = \frac{1}{F_{div}} \quad (3.5)$$

7- Utilization factor (F_u)

It is the ratio between the maximum demand of the system and the estimated capacity of the system.

$$F_u = \frac{D \max}{D \text{ rated}} \quad (3.6)$$

4) Transmission line:

It considers transmission line arteries of the electric power and it is a link between buses and carries the high voltages with long distance and fewer losses.

The power transmission either AC or DC, with the line designed by using one of the following species:

- **Overhead lines.**
- **Cables.**

Most are designed for power transmission lines operating in the three phase system, and is used in overhead lines connecting non-isolated (naked) with the benefit of air around your waist insulator,

Study transmission lines depend primarily on the performance characteristics of the electric transmission line. These properties can be expressed in the properties of the three-line order of importance:

- **Inductance line.**
- **Line capacity.**
- **Line resistance-**

Transmission lines are classified into short lines and medium and long lines, according to the length of the line, the difference between these species in the equivalent circuit of the line where they appear in the long and medium-capacity lines parallel to the line on the opposite short lines.

Short lines:

Lines that is no longer than 80 km.

Medium lines:

Are lines ranging in length from 80 km to 240 km equivalent circuit has the form T or form π .

Long lines:

Lines that is longer than 240 km.

3.3: The properties of the transmission line:

These properties represent the electrical performance of the line, if we consider the three-transmission line phase each connector represents resistance R with inductance L in parallel with the capacity C .

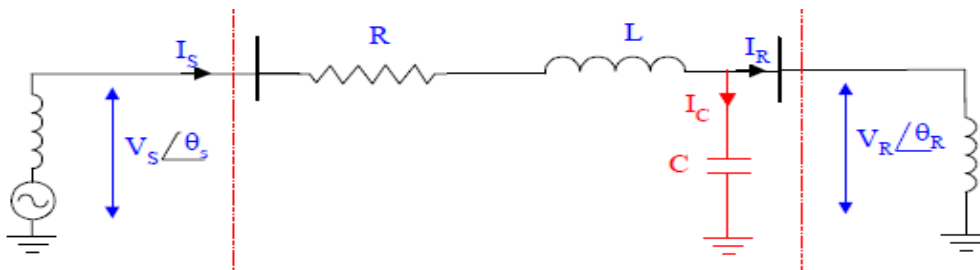

Fig.3.5: represent one phase transmission line

1-The Resistance:

Why resistance is classified as less important is its effect on the meager equivalent impedance of the line and thus the transmission line capacity.

We can get the value of the resistance of the following law.

$$\mathbf{R(\Omega) = \frac{\rho}{A}} \quad (3.7)$$

Where:

$\rho(\Omega.m)$: The resistivity of the conductive material.

A (m²): Area effect on the conductor.

In the case of aluminum conductor steel reinforced type ACSR, the exact information about the resistance can be obtained from the manufacturer's tables.

2-The line Reactance:

Inductance line properties are considered more important. For designs regular lines are inductive reactance $XL=\omega L$ is the dominant element of the impedance as a result of its impact on the delivery and low voltage capacity.

The reactance for one phase can calculate of the following low:

$$\mathbf{L = \frac{\mu}{2\pi} \left(\frac{1}{4} + \ln \frac{D}{r} \right) \mathbf{H/m}} \quad (3.8)$$

Where:

$\mu. =2\pi*10e-7$: magnetic force of the vacuum.

D: distance between conductors.

r: the radius of conductors.

If the distance between the conductors asymmetrical and differ from each other, the only change in the law will be:

$$D = \sqrt[3]{D_1 * D_2 * D_3} \tag{3.9}$$

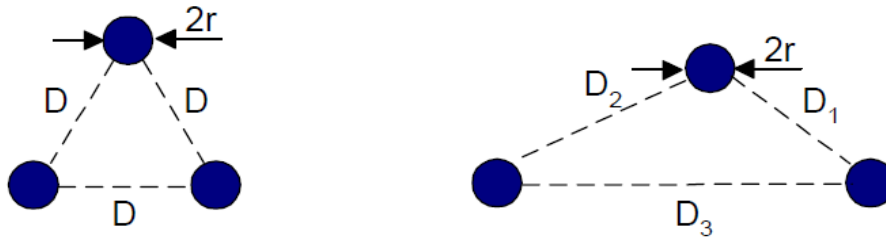

Fig.3.6: distance between conductors.

3-The Capacitance:

When the voltage is too high between conductors leaking electric current through the insulation, which is represented in the air overhead lines that power be ahead when the lack of load and knows current of charging and determines the value of this current line capacity and voltage sending and frequency.

Capacity represents the source of the ability of the reactor and fit this capability directly proportional to the square of the voltage sending. For transmission line over a length of about 100 km and beyond his 300 kV, the impact of parallel capacity becomes an essential part of the electrical system accounts.

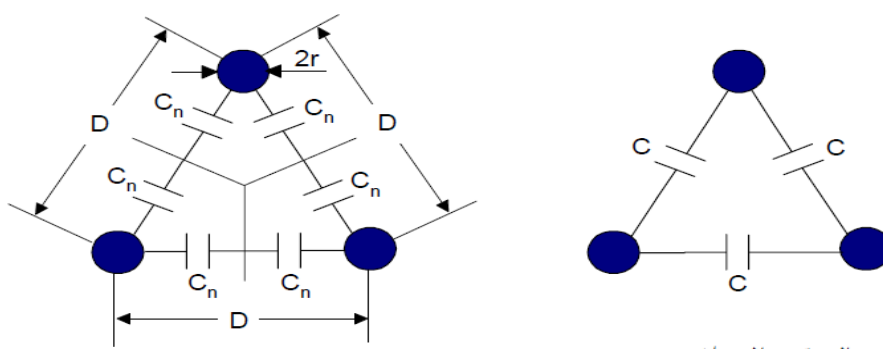

Fig.3.7: Each connector capacity with the neutral line of three phases.

The following equation represents the capacitance between the neutral and every meter of conductor transmission line for three phase line:

$$C_n = 2C = \frac{2\pi\mu}{\ln\frac{D}{r}} \text{ (F/m)} \quad (3.10)$$

Where:

μ . (Permittivity) = 8.854×10^{-12}

D: distance between conductors.

r: the radius of conductors.

C: capacitance between conductors.

If the distance between the conductors asymmetrical and differ from each other, the only change in the law will be:

$$D = \sqrt[3]{D_1 * D_2 * D_3}$$

Capacitive Reactance:

$$X_c = \frac{1}{\omega C_n} \text{ (ohm)} \quad (3.11)$$

Where:

- ω : $2\pi f$
- f: frequency.

Capacitive admittance:

$$Y = j\frac{1}{X_c} = j\omega C_n \text{ (Siemens)} \quad (3.12)$$

Summary:

This chapter is talking about the mathematical calculations that are needed in the analysis of the electrical grid in the village of Taffouh.

Chapter Four

Reactive power compensation

4.1 Overview.

4.2 Vega 78 power quality analyzer.

4.3 Industrial transformers load.

4.4 Correct power factor of industrial load.

4.5 Feasibility Study of Capacitors.

4.1 Overview:

The power system engineer should know the method of making load studies, fault analyses, and stability studies because such studies affect the design and operation of the system and the selection of apparatus for its control.

Before we can consider these problems in more detail, we must study some fundamental concepts relating to power system in order understand how the fundamental concepts affect the larger problems.

When designing an electric power system all possible scenarios must be studied and analyzed to choose the optimum one, the considered scenarios and configurations must pass through a technical study to be technically accepted, also, the considered technically accepted scenarios, after choosing the optimum design, the system must be tested to check its performance. So a load flow study must be performed, the power system must be optimized if there is necessary to rise the voltage of the busses or to reduce the losses of the network, when optimizing the network if you need to install capacitors in some heavy industrial loads in Taffouh .

For the study of the network and knowledge of the problems, we must analyze the network and find out the amount of electric loads on each transformer and redistribution of loads correctly on transformers. due to the lack of experience of the technocracy is difficult to know the amount of loads on the transformers so we need devices for measuring loads and electric power, and the analysis of the ability to both an electrical transformer, so we will use Vega device 78 power analyzer, this device measure wide range of power component and evaluate the power quality . In this stage of project we use it for taking an instantaneous reading of industrial transformers and domestic sector.

4.2 Vega 78 power quality analyzer:

Vega 78 power analyzer is a device used in the analysis and testing of the network whether in terms was a three-phase or single-phase with or without neutral. Which shows the basic values of current, voltage, power fact, power factor, and frequency (electrical quantities) by which to evaluate the electrical system, where the wavelengths of electrical quantities and drawings wavelengths electrical quantities appears. We use this to complete the rehabilitation the network through the measurement of electrical quantities crisis of the project, by downloading the data on the computer, follow a particular driver and re-analyzed to show the results system.



Fig.4.1. Vega 78 power quality analyzer device .

Recording parameters we need to project:

1. Voltage depth and peaks.
2. Vrms, Irms and Power, Energy.
3. $\cos \varphi$ (Power Factor).

4.3 Industrial Load

Industrial load consists of load demand by industries. The magnitude of industrial load depends upon the type of industry. Thus small scale industry requires load up to 25 kW, medium scale industry between 25kW and 100 kW and large-scale industry requires load above 500 kW. Industrial consumption in the town is increased randomly, where the sample was taken in the study is a Industrial consumption for the year 2015 (closed cycle), to see the amount of industrial consumption of the total loads electrical network, which contain a large proportion of industrial loads and the reason for that the cheap the subscription price for 3- phase that posed by the Taffouh municipality, as Table 4.1 Monthly consumption of industrial loads appear within 12 months where industrial loads consume 38% of the total energy, which is 4 MW for that cycle [1] .

Table 4.1: Industrial consumption per month .

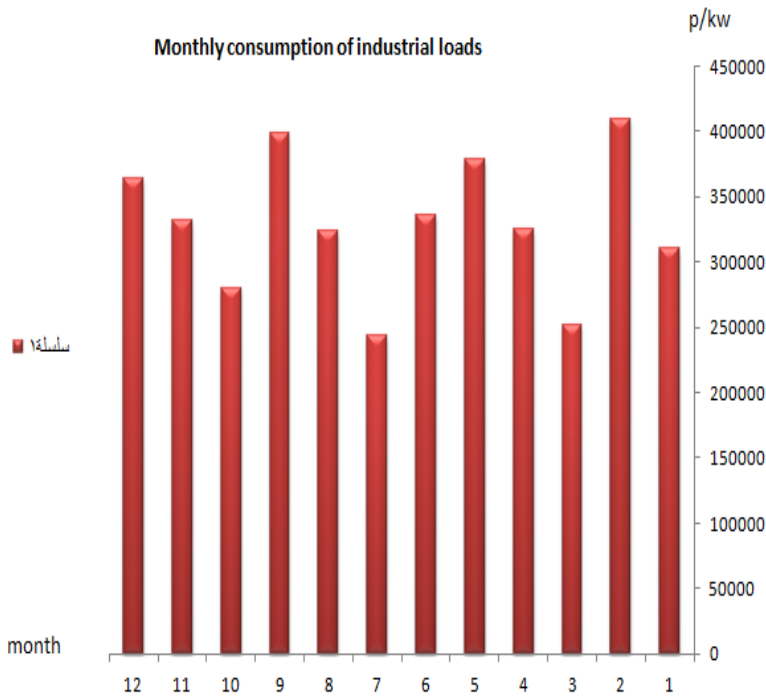

Fig.4.2 monthly consumption of industrial load

Month	KW	MW
Jan	309,936.0	0.309936
Feb	408,962.00	0.408962
Mar	251,662.00	0.251662
Apr	324,618.00	0.324618
May	377,838.00	0.377838
Jun	335,910.00	0.335910
Jul	243,376.00	0.243376
Aug	323,211.00	0.323211
Sep	398,431.00	0.398431
Oct	280,019.00	0.280019
Nov	331,076.00	0.331076
Dec	364,395.00	0.364395
Annual	3,946,504.00	3.946504



The analysis of industrial loads and finding industrial consumption of each 16 industrial loads for 12 Months and demand curve as it found in the Appendix C.

By finding demand curve for each industrial customers and Noncoincident maximum for each transformer to find maximum KVA diversified demand for each transformer would be by using mathematical calculation in chapter 3, by Dividing Noncoincident maximum on diversity factor for one customer (one feeder) as shown in Table 4.2, Then find a quotient Max.div.demand on power factor which was measured using a vega78 [5] .

Table4.2: diversity Factors

N	DF	N	DF	N	DF	N	DF	N	DF	N	DF	N	DF
1	1.0	11	2.67	21	2.90	31	3.05	41	3.13	51	3.15	61	3.18
2	1.60	12	2.70	22	2.92	32	3.06	42	3.13	52	3.15	62	3.18
3	1.80	13	2.74	23	2.94	33	3.08	43	3.14	53	3.16	63	3.18
4	2.10	14	2.78	24	2.96	34	3.09	44	3.14	54	3.16	64	3.19
5	2.20	15	2.80	25	2.98	35	3.10	45	3.14	55	3.16	65	3.19
6	2.30	16	2.82	26	3.00	36	3.10	46	3.14	56	3.17	66	3.19
7	2.40	17	2.84	27	3.01	37	3.11	47	3.15	57	3.17	67	3.19
8	2.55	18	2.86	28	3.02	38	3.12	48	3.15	58	3.17	68	3.19
9	2.60	19	2.88	29	3.04	39	3.12	49	3.15	59	3.18	69	3.20
10	2.65	20	2.90	30	3.05	40	3.13	50	3.15	60	3.18	70	3.20

Where:

N: number of load (feeders).

DF: diversity factor.

The following table.4.3 shows the industrial loads and math calculations we need to evaluate the situation of industrial load.

capacitor bank KVAR	Num Load	Noncoin. max (KW)/ Month	Noncoin. max (KW)/ hour	Max.div. demand (KW)	PF	Current loading KVA	Rated KVA	Loading degree
----	Load #1	17,829	99	99	0.55	180	400	Medium
100	Load #2	5,315	29.5	29.5	0.75	39.3	400	Low
----	Load #3	5,896	32.7	32.7	0.59	55.4	400	Low
----	Load #4	37,288	207	207	0.76	308.9	400	high
67.5	Load #5	33,054	183.63	183.63	0.78	235.5	630	Medium
----	Load #6	16,968	94.2	94.2	0.88	107.0	630	Low
100	Load #7	39,266	218.14	218.14	0.85	256.6	400	high
----	Load #8	1,643	9.1	9.1	0.94	9.68	400	Low
240	Load #9	10,905	60.58	60.58	0.73	82.9	630	Low
----	Load #10	5,345	29.69	29.69	0.85	34.9	400	Low
----	Load #11	SPARE	SPARE	SPARE	SPARE	SPARE	360	SPARE
240	Load #12	15,406	85.58	85.58	0.87	98.36	400	Low
----	Load #13	2,107	11.7	11.7	0.95	12.3	250	Low
----	Load #14	31,624	175.68	175.68	0.79	222.37	100	high
225	Load #15	70,362	390.9	390.9	0.74	528.2	630	high
60	Load #16	19,156	106.4	106.4	0.78	136.4	400	Medium

Summary:

The previous Table 4.2 show the Noncoincident maximum watt/h , Which Shows 25% of those transformers high loaded ,19 % work at medium loaded and 56% working under loaded.

4.4 Power Factor Improvement:

Power factor: is the ratio between the KW and the KVA drawn by an electrical load where the KW is the actual load power and the KVA is the apparent load power. It is a measure of how effectively the current is being converted into useful work output and more particularly is a good indicator of the effect of the load current on the efficiency of the supply system"[4].

All current will cause losses in the supply and distribution system. A load with a power factor of 1.0 result in the most efficient loading of the supply and a load with a PF of 0.5 will result in much higher losses in the supply system [4].

A poor power factor can be the result of either a significant phase difference between the voltage and current at the load terminals, or it can be due to distorted/discontinuous current waveform.

Poor load current phase angle is generally the result of an inductive load such as an induction motor, power transformer, lighting ballasts or welder.

A distorted current waveform can be the result of a rectifier, variable speed drive, switched mode power supply, discharge lighting or other electronic load.

A poor PF due to an inductive load can be improved by the addition of power factor correction, but, a poor power factor due to a distorted current waveform requires an change in equipment design to gain an appreciable improvement. [4].

Ranging power factor of the network in the domestic loads [0.84-0.99] and in industrial loads[0.55-0.94] ,and to determine the shunt capacitor bank required per kilowatt to improve power factor see the table in the Appendix B [4] .

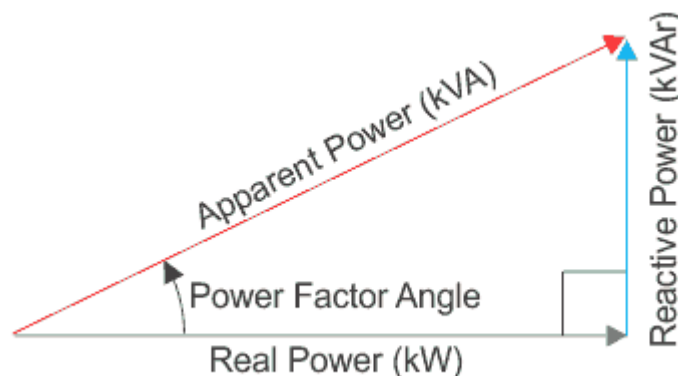

Fig 4.3: power triangle and power factor.

Mathematically, $S^2 = P^2 + Q^2$ and electrical power factor is active power / apparent power.

Capacitors bank:

Improving power factor means reducing the phase difference between voltage and current. Since majority of loads are of inductive nature, they require some amount of reactive power for them to function. This reactive power is provided by the capacitor or bank of capacitors installed parallel to the load. They act as a source of local reactive power and thus less reactive power flows through the line. Basically they reduce the phase difference between the voltage and current[4].

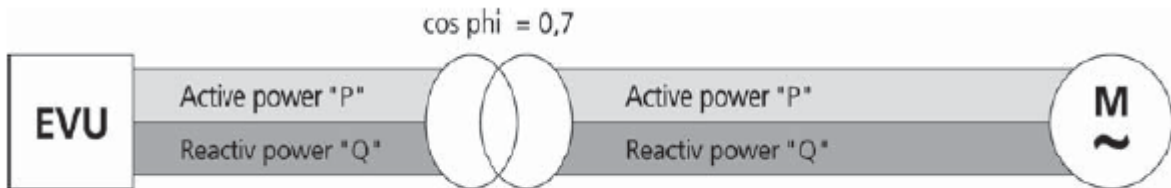

Fig 4.4 : Active and reactive power in the power distribution system without compensation.

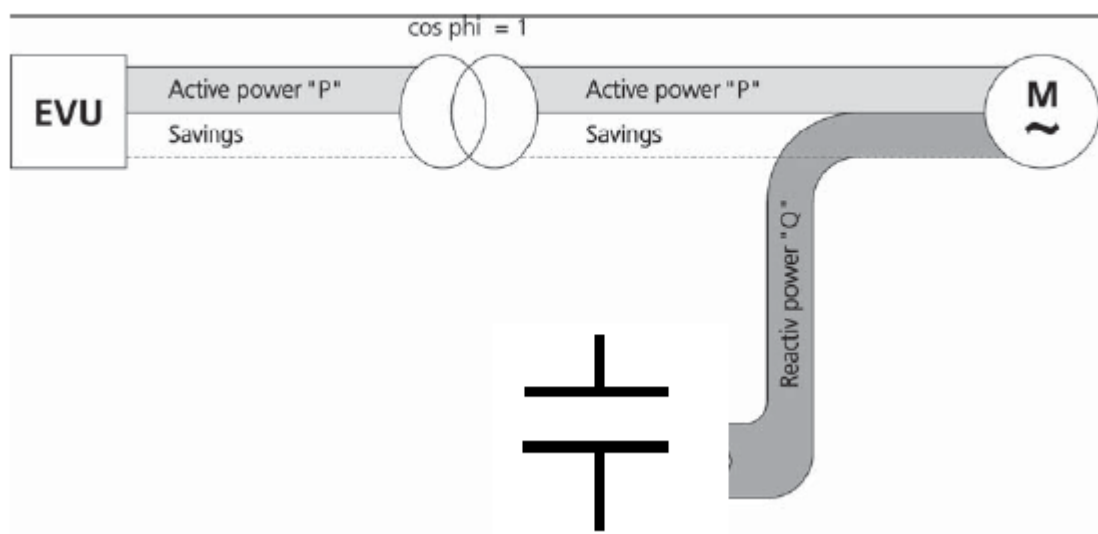

Fig 4.5: Active and reactive power in the power distribution system with correction

Methods of connecting capacitors to correct power factor:

1. Direct connection (fixed).
2. Automatic connection.
3. Mixed connection.

In the Taffouh network, the automatic and direct connection of the LKSLT 12.5-40-D30 capacitors on transformer is used to improve the power factor as the capacitors are connected through a device

step power factor " automatic reactive power control relays" [8] ,where they are connected using a special Contactor and protected using fuse as shown in the Figure 4.6 and Figure 4.7 .

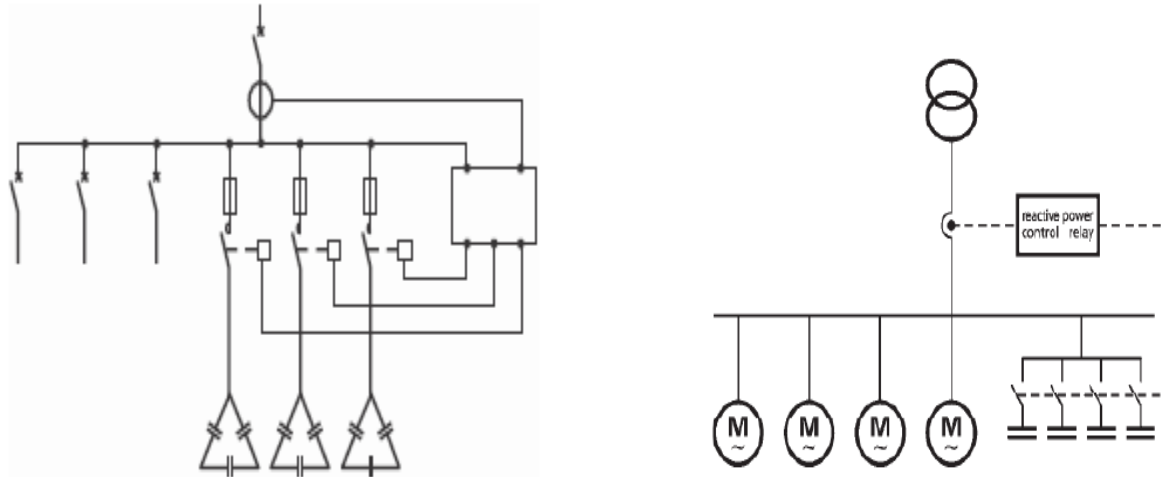

Fig 4.6: Automatic connection of capacitor with the transformer

A device an automatic power factor regulator, controls 12 sets of capacities and the power factor can be determined manually, it is very dangerous to connect the capacitors without the use of circuit breakers to protect the capacitor bank from short circuit and the engineer expects to short circuit on the capacitor lines [8].

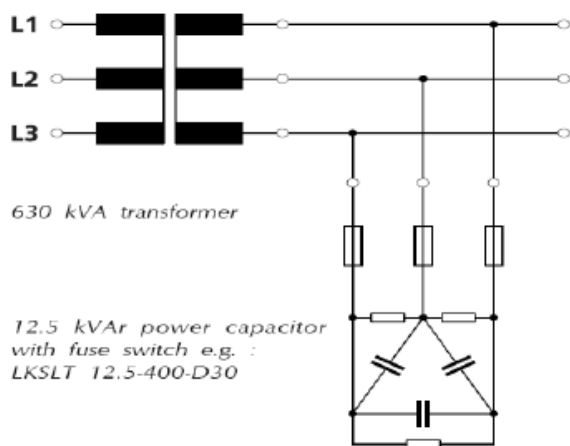

Fig 4.7 delta capacitor bank connected in transformer.

Where the power factor was improved from the existing values to a constant value of 0.98. by using Appendix B, The capacitors required for each load value were calculated to improve the power factor as shown in the table 4.4. Where 13 units of capacitors were placed on the industrial transformers to improve the power factor in the network.

Table 4.4: The requirement of capacitors to improve the power factor .

#of load	Pf1	Pf2	Num Bus	Max. Noncoincident. Kw\h	Required KVAR	Current capacitor bank	Selected (KVAR)
#1	0.55	0.98	39	99	130.284	-----	130
#2	0.75	0.98	13	29.5	20.03	100	20
#3	0.59	0.98	567	32.7	38.128	-----	37.5
#4	0.76	0.98	568	207	134.969	-----	135
#5	0.78	0.98	569	183.63	110	67.5	110
#6	0.88	0.98	570	94.2	31.745	-----	30
#7	0.85	0.98	573	218.14	90.964	100	90
#8	0.94	0.98	----	9.1	1.456	-----	-----
#9	0.73	0.98	571	60.58	44.40	240	45
#10	0.85	0.98	549	29.69	12.38	-----	12.5
#11	Spare	0.98	----	Spare	-----	-----	-----
#12	0.87	0.98	60	85.58	31.15	240	30
#13	0.95	0.98	----	11.7	1.470	-----	-----
#14	0.79	0.98	572	175.68	100.664	-----	100
#15	0.74	0.98	574	390.9	275.97	225	275
#16	0.78	0.98	4	106.4	64.033	60	65



To improve power factor from 0.55 to 0.98 of load number one by Multiplication maximum Noncoincident. Kw\h to constant collected from the Appendix B.

4.5 Feasibility Study of Capacitors:

A feasibility study is an analysis of how successfully a project can be completed, accounting for factors that affect it such as economic, technological, legal and scheduling factors. Project managers use feasibility studies to determine potential positive and negative outcomes of a project before investing a considerable amount of time and money into it.

Increase in benefits for one KVAR of additional compensation decrease rapidly as the system power factor reaches close to unity. This fact prompts an economic analysis to arrive at the optimum compensation level. Different economic criteria can be used for this purpose. The annual financial benefit obtained by using capacitors can be compared against the annual equivalent of the total cost involved in the capacitor installation. The decision also can be based on the number of years it will take to recover the cost involved in the Capacitor installation as example of fixed value compensation capacitors .A more sophisticated method would be able to calculate the present value of future benefits and compare it against the present cost of capacitor installation. The most important economic justification for the use of capacitors as follows:

- a) Benefits due to released generation capacity.
- b) Benefits due to released transmission capacity.
- c) Benefits due to released distribution substation capacity.
- d) Benefits due to reduced energy loss.
- e) Benefits due to reduced voltage drop.
- f) Benefits due to released feeder capacity.
- g) Financial Benefits due to voltage improvement.

Economic study money is the Backbones for any project with its both types. The project also saves money, strengthening human safety, reduce electricity outage Profit is the different between cost and revenue if the profit deserves the investment, the investors take a courage to perform the project. The previous scenarios to solve taffouh medium voltage network problem needs an economical study to decide if the project can be applied or not. Running cost cannot be detected because there's no enough information for estimate the maintenance per year. So depending on capital cost. Witch the total amount of money that's the project require to start consist the equipment, salaries ...etc. for the project we can Generalize that the capital cost is the equipment cost.

Table 4.5: Capacitor bank price .

Capacitor bank value	Price Nis / unite
50 Kvar	340
30 Kvar	250
25Kvar	230
20 Kvar	190
15 Kvar	160
12.5 Kvar	160
10 Kvar	160
7.5 Kvar	150
5 Kvar	130
2.5 Kvar	130

Table 4.6: contactor price .

Contactator	Price Nis / unite
50 Kvar	310
30 Kvar	220
25Kvar	200
20 Kvar	160
15 Kvar	130
12.5 Kvar	130
10 Kvar	130
7.5 Kvar	120
5 Kvar	100
2.5 Kvar	100

Table 4.7: Step device price .

Number of steps	Price Nis / unite
12 step	900
8 step	850
6 step	500
3 step	400



This information is provided by Al-Akhras Palestinian Company, which sells electrical parts for capacitors, fuses and contactors; where the price of fuses 40 Nis.

Table 4.8: LV 400 V Automatic Capacitor Bank Investments.

Num of load	capacitor bank selected	Number of steps	steps	Cap.Bank price	Steps price	Num of fuses	Fuses price/Nis	Num of contactors	Contactors price	Total
#2	20	3	10 7.5 2.5	160 Nis 150 Nis 130 Nis	400 Nis	3*3	360 Nis	3	130 Nis 120 Nis 100 Nis	1550 Nis
#5	110	6	30 30 20 15 10 5	250 Nis 250 Nis 190 Nis 160 Nis 160 Nis 150 Nis	500 Nis	6*3	720 Nis	6	220 Nis 220 Nis 160 Nis 130 Nis 130 Nis 120 Nis	3360 Nis
#7	90	6	30 25 15 10 10	250 Nis 230 Nis 160 Nis 160 Nis 160 Nis	500 Nis	5*3	600 Nis	5	220 Nis 200 Nis 130 Nis 130 Nis 130 Nis	2870 Nis
#9	45	3	20 15 10	190 Nis 160 Nis 160 Nis	400 Nis	3*3	360 Nis	3	160 Nis 130 Nis 130 Nis	1690 Nis
#12	30	3	15 10 5	160 Nis 160 Nis 150 Nis	400 Nis	3*3	360 Nis	3	130 Nis 130 Nis 120 Nis	1610 Nis
#15	275	8	50 50 50 50 30 20 15 10	340 Nis 340 Nis 340 Nis 340 Nis 250 Nis 190 Nis 160 Nis 160 Nis	850 Nis	8*3	960 Nis	8	310 Nis 310 Nis 310 Nis 310 Nis 220 Nis 160 Nis 130 Nis 130 Nis	5810 Nis
#16	65	3	30 20 15	250 Nis 190 Nis 160 Nis	400 Nis	3*3	360 Nis	3	220 Nis 160 Nis 130 Nis	1870 Nis
										18760 Nis

Table 4.8: LV 400 V Automatic Capacitor Bank Investments.

Num of load	capacitor bank selected	Number of steps	steps	Cap. Bank price	Steps price	Num of fuses	Fuses price/ Nis	Num of contactors	Contact ors price	Total
#1	130	6	50 30 20 15 10 5	340 Nis 250 Nis 190 Nis 160 Nis 160 Nis 150 Nis	500 Nis	3*6	720 Nis	6	310 Nis 220 Nis 160 Nis 130 Nis 130 Nis 120 Nis	3540 Nis
#3	37.5	3	20 10 7.5	190 Nis 160 Nis 150 Nis	400 Nis	3*3	360 Nis	3	160 Nis 130 Nis 120 Nis	1670 Nis
#4	135	6	50 30 25 15 10 5	340 Nis 250 Nis 230 Nis 160 Nis 160 Nis 150 Nis	500 Nis	3*6	720 Nis	6	310 Nis 220 Nis 200 Nis 130 Nis 130 Nis 120 Nis	3620 Nis
#6	30	3	15 10 5	160 Nis 160 Nis 150 Nis	400 Nis	3*3	340 Nis	3	130 Nis 130 Nis 120 Nis	1590 Nis
#10	12.5	3	7.5 5	150 Nis 150 Nis	400 Nis	3*2	240 Nis		120 Nis 120 Nis	1180 Nis
#14	100	6	30 25 20 15 7.5 2.5	250 Nis 230 Nis 190 Nis 160 Nis 150 Nis 130 Nis	500 Nis	3*6	720 Nis	6	220 Nis 200 Nis 160 Nis 130 Nis 120 Nis 100 Nis	3260 Nis
										14860 Nis

The total capacitor bank price of **13** industrial transformers is:

$$18760 \text{ Nis} + 14860 \text{ Nis} = 33620 \text{ Nis}$$

Table 4.9 describes the network and the information of the power factor, voltage, current and total capacity of the network before treatment.

Table 4.9: Network mode and consumption .

ID	Rating	Rated Kv	MW	Mvar	Amp	%PF
IEC	5MVA	33KV	3.436	2.012	69.67	86.29

To calculate the value of the annual profits, the difference in losses in the network must be known before the amendment process and after the adjustment process, as follows:

Table 4.10: Total losses in network.

Before added capacitor	KW	KVAR
Losses	100	-144

After building a new modeling of network with a new capacitor bank by using ETAPE the total losses in network as shown in the table 4.11.

Table 4.11 total losses in network

After added capacitor	KW	KVAR
Losses	41.8	-276.1

$$P_{\text{annual}} = \text{power} \times (\text{hours} / \text{year}) \quad (4.1)$$

$$P_{\text{annual}} = 58.2(\text{KW}) \times 8760(\text{hour/year})$$

$$P_{\text{annual}} = 509832 (\text{KW hour} / \text{year})$$

While taking the price of KWH is (0.57) Nis

$$\text{Saving} (\$) = 509832(\text{KW hour} / \text{year}) \times (0.57) \text{ Nis} / (\text{KW hour}) \quad (4.2)$$

$$\text{Saving} (\$) = 290604.42 \text{ Nis/year}$$



When installing capacitors and paying the amount and value 33620 Nis We saving 290604.42 Nis/ year

IEC imposes penalties when the power factor is low in the network. Table 4.12 shows the penalties imposed by the company.

Table 4.12 penalties imposed of power factor

Power Factor	Pf -penalties
$P.F \geq 0.92$	No Penalties.
$0.92 > P.F \geq 0.8$	1% of total bill for each one under 0.92
$0.8 > P.F \geq 0.7$	1.25% of total bill for each one under 0.92
$P.F < 0.7$	1.5% of total bill for each one under 0.92

Where the power factor is in the network before the process of improving the power factor is 86.80752 and after improving power factor in network is 97.06 so the penalties imposed of Taffouh network is 1% of the total bill for each one under 0.92 , so the total penalties is 6% of total bill. Where the maximum demand of loads in the grid and the power factor in the Appendix D1 and D2 .

$$\text{Power average} = L.F \times \text{power max} = 0.75 \times 3.241 = 2.43075 \text{ MW} \quad (4.3)$$

$$\text{Total energy per year} = \text{power average} \times 8760 = 21293.37 \text{ MWH} \quad (4.4)$$

$$\begin{aligned} \text{Total cost per year} &= \text{Total energy} * \text{cost NIS/KWH} \quad (4.5) \\ &= 21293.37 \times 0.57 \text{ NIS} = 12137220.9 \text{ NIS/year} \end{aligned}$$

$$\begin{aligned} \text{Saving in penalties of P.F} &= \text{total cost per year} \times \text{penalties of pf} \quad (4.6) \\ &= 1237.2209 \times 0.06 = 728233.254 \text{ NIS/year} \end{aligned}$$



When the power factor is improved from 86.80752 to 0.92 we saving 728233.254 NIS/year, to see more details about summary of total generation, loading, power factor and demand see Appendix D1 and Appendix D2.

Chapter Five

Electricity sector status in the Taffouh town

5.1 E-TAP Program data.

5.2 Domestic transformer load.

5.3 Domestic load growth.

5.4 Problems and recommendation.

5.1 E-TAP program:

ETAP (Electrical Transient Analyzer Program) is the most comprehensive solution for the design, simulation, and analysis of generation, transmission, distribution, and industrial power systems Fig 5.1 [7]. In addition, using its standard offline simulation modules, ETAP can utilize real-time operating data for advanced monitoring, real-time simulation, optimization, energy management systems and high-speed intelligent load shedding [7].

ETAP offers a suite of fully integrated electrical engineering software solutions including arc flash, load flow, short circuit, transient stability, relay coordination, cable capacity, optimal power flow, and more [7]. Here we are use electrical transient analyzer program 12.6 to design, simulation, and analysis Taffouh electrical of 33 kV/0.4kV distribution system. Fig .5.2 show a snap-shot of the interface of ETAP program.

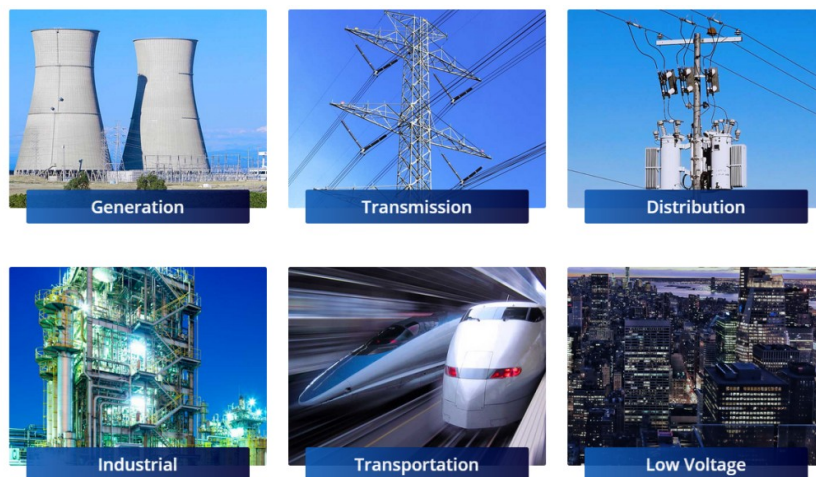

Fig .5.1: Systems that are built using ETAP .

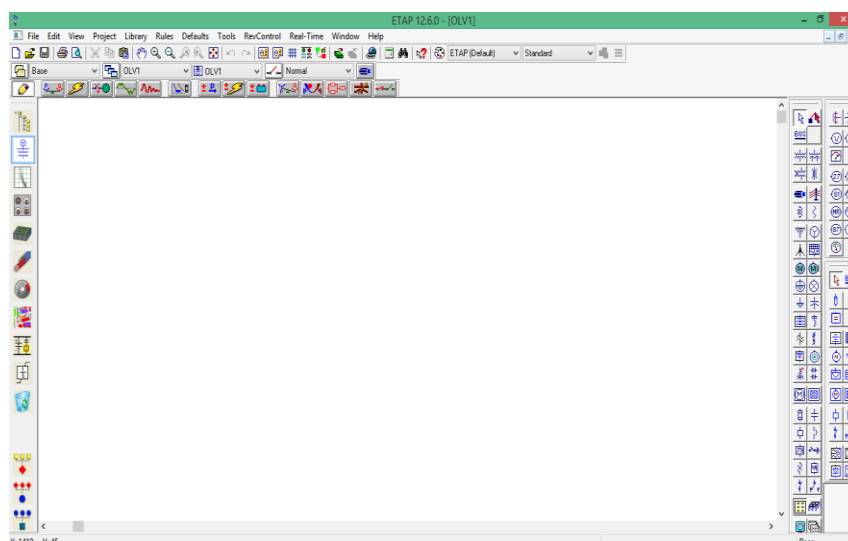

Fig .5.2: The ETAP interface

A load flow study should be performed during the planning design stages of a power system and when evaluating changes to an existing system. A load flow study calculates the voltage drop on each feeder, the voltage at each bus, and the power flow and losses in all branch and feeder circuits. Load flow studies determine if system voltages remain within specified limits under normal or emergency operating conditions, and whether equipment such as transformers and conductors are overloaded.

In this project we will study this specification in ETAP:

1. Load Flow Study.
2. Voltage Drop.
3. Prance loss.
4. Power Factor Correction
5. Protective Device Coordination.

In Appendix D1, ETAP report for all study of electrical Taffouh network as built as in reality without reclamation; this data includes the series impedance and shunt admittances of the transmission line, other essential information includes transformer tap setting, data about the nominal voltages and the load power and the generated power and study specification. The filling data in project by using user's Guide [7].

5.2 Domestic transformer load:

Domestic load is a term which is used to describe the amount of electricity entering a domestic at any given time. The amount of electricity a domestic can access is typically limited by the amount of its service drop. When homes are constructed or electrical systems are renovated, an electrician must perform a number of calculations to estimate maximum domestic load to determine how the system should be laid out, with the goal of preventing electrical problems caused by overloading the system. In some regions of the world, utilities have promoted load management programs which are designed to compensate for aging electricity grids by managing the use of power at peak times. These programs also generate savings for utility customers, helping them spend less on electricity. Load management programs control high-load electrical devices like water heaters and fridges, deferring electricity use during peak periods to free up power resources. Domestic load calculations determine the amount of service drop appropriate to domestics, the type of wiring which should be used, and how circuits should be arranged. Electricians also perform calculations to determine the heating and cooling needs of a structure so that the best system can be installed. A system which is too small will not be sufficient, while a system which is too large will be inefficient. Installing the right system will cut energy costs and keep the temperature more comfortable .and in Taffouh electrical network 19 domestic Transformer feed 2600 domestic load and Table 5.1 show the domestic loads consumption Which was taken from power analyzer ,to see more detailed about consumption of domestic load every hour see Appendix c1 .

Table 5.1: the category of 19 domestic transformers, number of feeders and the region of transformer

Num	Existing TR. (KVA)	Max. Load KVA	PF	Category	diversity Factors	Load	Measurements
1	400KVA	37	0.83	Low	3 feeders 1.8	اسطاس	Two hour reading at morning
2	630KVA	123.35	0.95	Low	2feeders 1.6	ادغيبس 1	Two hour reading at morning
3	630KVA	63.04	0.92	Low	4 feeders 2.10	اول البلد (هاني)	Two hour reading at morning
4	150KVA	55	0.84	Medium	4 feeders 2.10	الحورة (وجيه)	Two hour reading at morning
5	630KVA	270	0.90	Medium	4 feeders 2.10	الحورة (رسمي)	Two hour reading at evening
6	400KVA	110	0.97	Medium	1 feeder 1	كروم الغرباء (ابو عماد)	Two hour reading at evening
7	630KVA	450	0.91	High	4feeders 2.10	وسط البلد	Two hour reading at evening
8	250KVA	43.4	0.92	Low	4feeders 2.10	قرنة الفننة	Two hour reading at morning
9	250KVA	9.54	0.98	Low	1 feeders 1	القطروانية	Two hour reading at evening
10	250KVA	12.14	0.95	Low	2 feeders 1.6	ادغيبس	Two hour reading at morning
11	150KVA	58.13	0.67	Medium	4 feeders 2.10	لوزة 1	Two hour reading at morning
12	400KVA	62	0.91	Low	1 feeder 1	لوزة 2	Two hour reading at evening
13	400KVA	98	0.88	Low	3feeders 1.8	القرنة	Two hour reading at evening
14	400KVA	55.4	0.92	Low	3 feeders 1.8	ابو دعجان	Two hour reading at evening
15	400KVA	168.4	0.95	Medium	4 feeders 2.10	السعايدة	Two hour reading at evening
16	250KVA	84.25	0.83	Medium	4feeders 2.10	كروم الغرباء	Two hour reading at evening
17	400KVA	78	0.95	Low	4feeders 2.10	الخمجات واد عزيز	Two hour reading at evening
18	250KVA	14.36	0.88	Low	2feeders 1.6	المحزم	Two hour reading at morning
19	150KVA	8.6	0.92	Low	3feeders 1.8	عين البستان	Two hour reading at evening

5.3 Load growth of domestic load:

Increase in energy demand, either through natural growth of a service territory resulting from increased prosperity, productivity or population growth, or through stimulation of the energy market.

Where Table 5.2 shows the population and energy demand in the last 10 years [1] , and Table5.3 shows the load growth in 15 year Coming the consumption will be 22 MW .

Table 5.2 shows the population and energy demand in the last 10 year .

Year	Population	energy demand(KW)
2007	10,438	4,356872,12
2008	10,788	5,215308,98
2009	11,150	5,874561.85
2010	11,522	6,423456.12
2011	11,907	6,652211.241
2012	12,305	6,852230.152
2013	12,714	7,264360.135
2014	13,123	7,685088.590
2015	13,559	9,396395.31
2016	14,000	10,943691.210

Table5.3 .the load growth in 15 year.

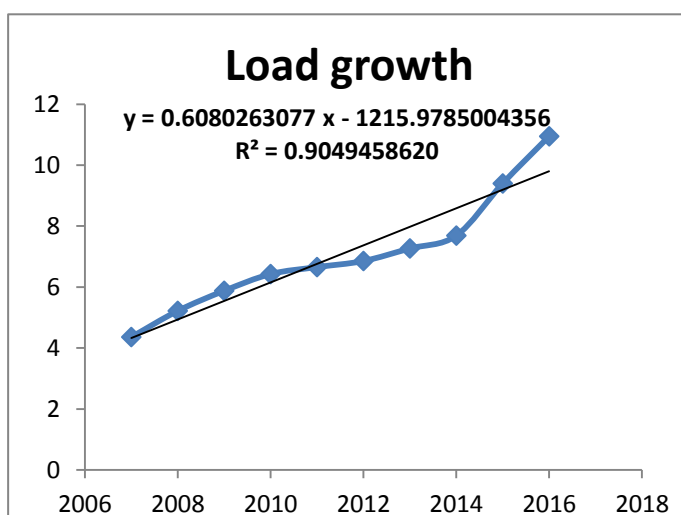

Year	energy demand (MW)
2016	13.78
2017	14.39
2018	15.00
2019	15.61
2020	16.22
2021	16.83
2022	17.44
2023	18.05
2024	18.66
2025	19.27
2026	19.88
2027	20.49
2028	21.1
2029	21.71
2030	22.32

Fig .5.3: Population growth curve and the nearest mathematical equation to him

5.4 Problems and recommendation:

1) Problems

In Taffouh village the network suffers of several large and small problems as they are in the Appendix D1. Which effect on network dramatically, that's lead to the existence of losses in the network from the side economic and electric. The most important of these problems:

- 1- Taffouh network has high losses where the total losses in the network 100 kW/h.
- 2- Taffouh network has very low power factor range in industrial load Ranges from (0.55-0.95).
- 3- Taffouh network has voltage drop where the maximum value of the voltage drop 16.8 %.
- 4- Problem in equipment.
- 5- Other problems.

To solve problems and reduce losses in the network must study and analysis load flow, the most important information obtained from the load flow analysis is the voltage profile of the system. If voltage varies greatly over the system, large reactive flows will result. This, in turn, will lead to increased real power losses and, in extreme cases, an increased likelihood of voltage collapse. When a particular bus has an unacceptably low voltage, the usual practice is to install capacitor banks in order to provide reactive compensation to the load. Load flow studies are used to determine how much reactive compensation should be applied at a bus, to bring its voltage up to an appropriate level. If new lines (or additional transformers) are to be installed, to reinforce the system, a power flow study will show how it will relieve overloads on adjacent lines. An inefficient or unbalanced load can also cause unpredictable behavior in your localized power grid, increasing the risk of equipment damage and unplanned outages. Load flow studies are commonly used to:

1. Optimize component or circuit loading.
2. Develop practical bus voltage profiles
3. Identify real and reactive power flow
4. Minimize KW and KVAR losses
5. Develop equipment specification guidelines
6. Identify proper transformer tap settings.

Our goal is to reduce the problem and improve the voltages within the range by using the following steps:

1. Tap changing in the transformers.
2. Adding capacitors to produce reactive power.
3. Changing and replacing transformer.
4. Add another connection point.
5. Replace some of transmission line.
6. Set protective devices to protect wires and transformers.



In the Appendix D2 we show the result of network after fixed the loses parameter's , the total losses .To achieve the objectives of the project mentioned in the first chapter and in Appendix D3; network scenario with industrial load only, which accounts for 35% of the total consumption of the town .

Other problems:

Engineering planning remains without external constraints and external problems, that effect in Taffouh network loss in first order ; this problem hinder engineers to calculation of network losses ideally. This problem can also lead threat of human life and network component due to the current location of the parts (Tower, Transformer, Transmission line). These problems are as follows :

1. Expertise weak (Poor men craft).
2. Some of the towers are a not suitable location for housing.
3. Network suffers from a lack of regular maintenance.
4. Isolator is not clean and dirty.
5. Some of transformers to rise from the earth, and is not suitable destination.



Fig 5.4: Isolator is not clean and dirty.



Fig.5.5: transformers to rise from the earth, and is not suitable destination .

2) Recommendation:

We want to solve these problems in the network in order to reach the ideal network free of errors and problems, to minimize the loss . These are some of the proposed solutions to solve some of the problems.

1. Use correct values for protection devices (fuses, circuit breakers) as found in the corrective network model provided in the Appendix D2 'to protect transformers and transmission lines.
2. Achieve network reliability by connecting a new 33 kV connection point as described in the Appendix D2; as to reduce radial network problems.
3. Provide technical and engineering expertise to the cadres to achieve engineering work ethics (The right man in the right place).
4. Continuous maintenance of live parts and continuous cleaning of isolator and replace the parts are out of action.
5. Choose the correct positions for the 33 kV towers , transformer and transmission line so that they are far from the residential building and replace the other to underground cables where it requested the conditions and financial and housing.
6. Select correct capacitor values to improve the power factor and replace the unemployed as in the third chapter of the project.



All of the recommendations mentioned are found in the new model of the network in the Appendix D2 as report and schematic.

Appendix

Appendix A: Infrastructure of network.

Appendix A2: The electrical map of main transmission line, cable, transformer and tower in Taffouh town.

Appendix B: Power factor correction table.

Appendix C: Loads during the course of 12 months for the special industrial transformers, For the year 2015.

Appendix C1: consumption of domestic load every hour.

Appendix D1: ETAP result of network before fixed the loses parameter's and the current network model.

Appendix D2: ETAP result of network after fixed the loses parameter's and modified network model.

Appendix D3: ETAP result of network scenario with industrial load only and network model.

References:

[1] Taffouh Municipality, <http://taffouh.org/> .

[2] Isoelectric, ZINC OXIDE SURGE ARRESTER M.V. and H.V. HOUSED INSILICONE, Surge arresters ISI-EGC33, www.contragent.com/files/mf/product_catalogs/85_uploaded_file.pdf.

[3] Colin Bayliss. "Transmission and distribution electrical engineering". Newnes, 1999.

[4] WEG ELECTRIC CORP, Power Factor Correction, IEC60831 Condensator capacitor , <http://ecatalog.weg.net/files/wegnet/WEG-power-factor-correction-usa3846pf-brochure-english.pdf> .

[5] William H. Kersting. "Distribution System Modeling and Analysis". CRC Press, 2001.

[6] Mouser Electronics, HRC Fuse, www.mouser.com/ds/2/87/LV_030507-357290.pdf. High Voltage (HV) DIN Fuse Links, 33-36kV - Current Limiting Back-up Fuses, www.cablejoints.co.uk/sub-product-details/cable-socks/hv-fuses-bussmann-33kv-36kv

[7] Keith Hill E-tap. E-tap 9. E-tap web, 2008.

[8] Power Factor Correction Capacitors in sheet steel cases <http://www.frako.com/fileadmin/pdf/Produkte/Leistungs>