

Palestine Polytechnic University



College of Engineering & Technology
Mechanical Engineering Department
Refrigeration And Air Conditioning

CONTROLLING AND MONITORING OF SIMPLE REFRIGERATION CYCLE

Produced by:
Mohammad Mo'men Jawadeh

Supervisor:
Dr. Ishaq sider

Hebron – Palestine

2016-2017



Palestine Polytechnic University

Collage of Engineering

Mechanical Engineering Department

Hebron – Palestinea

**CONTROLLING AND MONOTORING OF SIMPEL REFRIGERATION
CYCLE**

By

Mohammad Momen Jawadeh

Submitted to the Collage of Engineering

In partial fulfillment of the requirements for the

Bachelor degree in Refrigeration and Air Conditioning Engineering.

Supervisor Signature

.....

Testing Committee Signature

.....



.....
C.12/A/C1

Chair of the Department Signature

.....

Aug. 2017

Dedication

This project is dedicated to my father, who taught me that the best kind of knowledge to have is that which is learned for its own sake. It is also dedicated to my mother, who taught me that even the largest task can be accomplished if it is done one step at a time.

Acknowledgements

Dr. Ishaq Sider has been the project supervisor. His wise advice, insightful criticisms, and patient encouragement aided the writing of this project in innumerable ways. I would also like to thank Dr. Iyad Hashlamon, Dr. Diya Arafah, Eng. Khaled Sider and Eng. Suhaib Aldweik. Whose steadfast support of this project was greatly needed and deeply appreciated.

Table of Contents

Chapter 1	Page
Introduction	1
Chapter 2	
Controller design	7
Chapter 3	
Simulation and dynamic analyses	18
Chapter 4	
System identification and PID design	37
Chapter 5	
Result and future work	52
References	58

Abstract

In this project a new temperature controller was designed to replace the conventional on-off temperature controller to maintain the inner temperature of a simple refrigeration cycle and reduce the power input to the cycle. Due to the effect of high demand of power on the green house emission it is important to find new ways for power production. Also, the another important issue which is unnoticed is make sure that the power produce consumed efficiently by the load. The main concentration of research in the subject is the replacement of old systems to new in order to reduce power consumption which is a topic of interest to most researcher nowadays. This is done by adjusting the power absorbed by the system to meet the demand using variable frequency drive. Both temperature controllers of the conventional system and the new controller were designed and evaluated. Results showed that the controller was found to be more consistent and effective in maintaining the inner temperature of the simple refrigeration cycle. The both results provide full graphical development which is analyzed and have been compared. The effectiveness of the controller and its ability to maintain the inner temperature of the simple refrigeration cycle with consistency moreover the conventional on-off controller. Also the controller was able to reduce the vibration and noise produced by the cycle.

List of figures.

Figure	Name	page
Figure 2.1	Electrical component of AC motor	7
Figure 2.2	Mechanical component of reciprocating compressor	8
Figure 2.3	closed loop control system diagram	10
Figure 2.4	variable frequency drive working principle	11
Figure 2.5	Control circuit	15
Figure 2.6	Power circuit	16
Figure 3.1	Simple vapor-compression refrigeration cycle model	18
Figure 3.2	Closed loop controller simulation	19
Figure 3.3	Controller simulation	20
Figure 3.4	Response for the temperature verses time	20
Figure 3.5	Compressor power versus time	21

Figure 3.6	Pressure in the inlet and the outlet of the compressor versus time	22
Figure 3.7	Pressure ratio of the compressor versus time	23
Figure 3.8	Simple vapor compression refrigeration cycle using the new PID control system	24
Figure 3.9	Close loop PID control system	25
Figure 3.10	Response for the temperature versus time when using PID control system	26
Figure 3.11	The power consumes by the compressor when use the PID control system	27
Figure 3.12	The compression ratio for the compressor when using The PID control system	28
Figure 3.13	Pressure in the inlet and the outlet of the compressor versus time when using PID controller	29
Figure 3.14	Hermetic reciprocating compressor	30
Figure 3.15	Compressor modeling	31
Figure 3.16	Compressor modeling equivalent	31
Figure 3.17	Acceleration with time when the frequency is 50 Hz	33

Figure 3.18	Acceleration with time when the frequency is 30 Hz	33
Figure 3.19	Amplitude of the voice versus time when the frequency is 50 Hz	34
Figure 3.20	Amplitude of the voice versus time when the frequency is 30 Hz	35
Figure 4.1	The close loop control system	37
Figure 4.2	Response at step input	38
Figure 4.3	System identification tool	39
Figure 4.4	Response with one pole and no zeros	40
Figure 4.5	Response with two poles and one zero	41
Figure 4.6	Response with three poles and two zeros	41
Figure 4.7	Response with four poles and three zeros	41
Figure 4.8	Transfer function	42
Figure 4.9	Root Locus	43
Figure 3.10	Block diagram for the system with PID controller	44
Figure 4.11	Block diagram for the system	45
Figure 4.12	Step response	45

Figure 4.13	Z-transformation	46
Figure 4.14	Raspberry-Pi	47
Figure 4.15	Touch screen	48
Figure 4.16	Serial communication between the Arduino Micro-controller and Raspberry-Pi	49
Figure 4.17	The block diagram for the system with the surrounding temperature	50
Figure 4.18	Output response	51
Figure 5.1	Power response with the old conventional ON/OFF controller	52
Figure 5.2	Power response with the old conventional PID controller	53
Figure 5.3	Output response	55
Figure 5.4	show the low side pressure and the high side pressure when using the conventional ON/OFF controller	56
Figure 5.5	show the low side pressure and the high side pressure when using the PID controller	56

List of Tables.

Table	Name	Page
Table (1-1)	Time table for the first semester	3
Table (1-2)	Time table for second semester	4
Table (1-3)	Budget	5

Chapter one

Introduction

List of Tables.

Table	Name	Page
Table (1-1)	Time table for the first semester	3
Table (1-2)	Time table for second semester	4
Table (1-3)	Budget	5

Chapter one

Introduction

Table 10.1

1.1.1

1.1.2

1.1.3

1.1.4

1.1.5

1.1.6

1.1.7

1.1.8

Chapter one

Introduction

1.1.9

1.1.10

1.8 budget

It has been estimated that the budget and cost of this project as shown in table 1.3.

Table 1.3 budget

Variable frequency drive	200 \$	1	200 \$
Arduino microcontroller	20 \$	1	20\$
Touch screen	100 \$	1	100 \$
Wires, contactor, timer... etc.	-	-	100 \$
Total cost			420 \$

2.1 Introduction

In many applications, the control system of the refrigeration cycle employs a conventional ON / OFF controller. In which the controller switches the motor ON when the temperature reaches a set value, then switches the motor OFF when reached the required value. The controller main function is to switch the motor on and off depending on the temperature. In the present work, a substitute for conventional controlling circuit is proposed. In the proposed technique the controller varies the motor speed in order to acquire the required value of temperature. Moreover, when varying the motor speed the type of motor is important, because varying the speed of motor depends on motor type. In the present work an AC motor is proposed. The AC motor vary in speed by changing the frequency of the voltage which is fed into the motor. By finding a relation between the temperature and frequency and implementing it on a live system a better performance is acquired.

2.1.1 Electrical AC motor

In AC motors the the frequency is directly proportional to the speed of rotation. Equation (2.1) shows the relation between the frequency and the mechanical speed. Also, in the Figure 2.1 the main component of AC machine is shown. Where ω and f is the mechanical speed and electrical frequency, respectively.

$$\omega = \frac{120 \times f}{\text{number of poles}} \quad \text{Equation (2.1)}$$

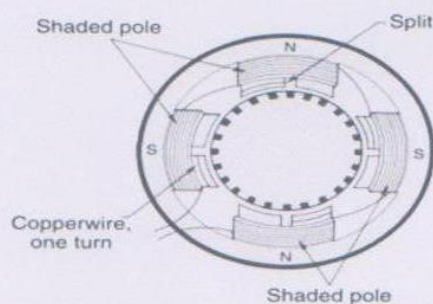

Figure 2.1 Electrical component of AC motor.

Chapter two

Controller design

1.1 Introduction

In the past few years the issue of power consumption is considered one of the major concerns all over the world. Nowadays, green power and innovation of new devices that give better performance with lesser power rating is a major topic in most fields of study. Also the comfort was and still one of the key goals of any major industry. In this study, a combination of both goals - achieve a product that makes the most efficient of the power. While reducing the noise from the mechanical part to increase the comfort- will be subject of study. In the new age our life style and daily living is dependent in many great innovations one of which is the air conditioning systems, and the refrigeration cycle is considered the main component of these systems. Simple as it is the control on these systems survived for many years without much change ON/OFF control system. But with ongoing development of control systems and electronics these controllers are considered ancient and obsolete.

In recent years many studies suggested the change of some parts to improve the performance of the control system. Although, some increase the efficiency but without tackling the main issue. Also there are many implemented systems in which changing some parts is considered difficult. In this project a development of a new and better controlling circuit for the refrigeration cycle is under study. With the use of power electronics and microprocessors to achieve better performance in both efficiency and comfort. Also without any change to the already used parts. The new controlling method will make users to be more involved in the controlling of the refrigeration cycle because it will provide a better monitoring system and increase parameters to enhance the performance attributes.

1.2 Background

In [1] the author used scroll compressor with different type of controller to control the refrigeration cycle. In each case the author estimates the power consumption, in order to find the controller that

controlled the refrigeration system and consumed less power. In his work the main component of the cycle which is the compressor is changed. Instead of reciprocating compressor he works with scroll compressor. The difficulty of using reciprocating compressor is that no direct relation can match between the temperature and changing of speed of rotation.

In [2] the work is done to control the speed of rotation of the evaporator fan. In order to increase forced heat transfer by convection of the evaporator surfaces. Evaporator AC fan motor controlled by using variable frequency drive by changing the frequency in to the motor. The author still used the conventional ON / OFF controller but reduce the power consumption by the evaporator fan motor.

In [3] author works with HVAC system. Controlling of the air supply fan speed using the same principle of variable frequency drive. By controlling the speed of rotation of the fan motor the mass flow rate adjusted to meet the required demand in the conditioning space. In the present work a new model for controlling the refrigeration system is under study. In this work, common compressor type and with variable speed control is used.

1.3 Importance of the project

The most critical problem in the world is to meet the energy demand, because of steadily increasing energy consumption. Refrigeration systems' electricity consumption has big portion in overall consumption. Therefore, considerable attention has been given to refrigeration capacity modulation system in order to decrease electricity consumption of these systems. Capacity modulation is used to meet exact amount of load at partial load and lowered electricity consumption by avoiding over capacity using. Variable speed refrigeration systems are the most common capacity modulation method for commercially and household purposes. Although the vapor compression refrigeration designed to satisfy the maximum load, they work at partial load conditions most of their life cycle and they are generally regulated as on/off controlled.

1.7 Time table:

Duration of the project for the first and second semester has been estimated to be around 16 weeks for each.

Table (1-1) Time table for the first semester.

Task	Weeks															
	1	2	3	4	5	6	7	8	9	10	11	12	13	14	15	16
Estimate goals of project	█	█														
Learning, setting project concepts and goals		█	█													
Establishing scientific background			█	█	█	█										
Studying the different type of controller						█	█	█	█							
Simulation model and monitoring system									█	█	█	█				
Dynamic analyses and experiments												█	█			
Analyzing data														█	█	
Writing report								█	█	█	█	█	█	█	█	
Presentation															█	█

Table (1-2) Time table for second semester.

Task	Weeks															
	1	2	3	4	5	6	7	8	9	10	11	12	13	14	15	16
Set and review goals of project	█	█														
Select the refrigeration cycle		█														
Take readings		█	█	█												
Analyzing data				█	█											
Building of controller					█	█	█	█								
Test the controller							█	█	█							
Write the project report								█	█	█	█	█	█			
Writing documentation														█	█	
Printing documentation out															█	█

In the present work, the AC motor when the cycle has a speed control mechanism with controls the speed by tampering with the frequency.

2.1.2 Reciprocating compressor

From the analyses for the reciprocating compressor the changing in rotation speed of the compressor, the volumetric flow rate will also change. This change is derived from formula of volumetric flow rate Equation (2.2).

$$\dot{V} = \omega \times V \quad \text{Equation (2.2)}$$

Where \dot{V} is the volumetric flow rate and V is the volume of the compressor cylinder as shown in the Figure 2.2.

$$V = \text{stroke} \times \frac{\pi}{4} \text{bore}^2 \quad \text{Equation (2.3)}$$

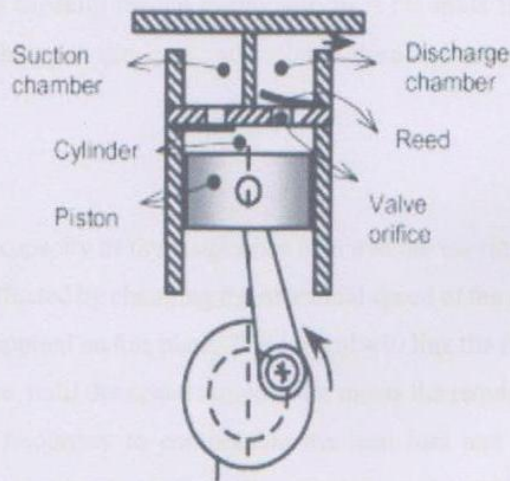

Figure 2.2 Mechanical component of reciprocating compressor.

The mass flow rate in the discharge line of the compressor is equal to the volumetric flow rate multiply by the density of the fluid.

$$\dot{m} = \dot{V} \times \rho \quad \text{Equation (2.4)}$$

where \dot{m} is the mass flow rate and ρ is the density of the fluid.

From electrical analyses and the mechanical analyses that noticed the change in the frequency feeding the compressor will change the speed of rotation. The change in speed of rotation will lead to a change in volumetric and mass flow rate coming out from the compressor.

2.1.3 Cooling load

From the thermodynamic analyses for simple refrigeration cycle. The evaporator load will change by changing the surrounding conditions like surrounding temperature and the heat gain, the heat transfer from the evaporator to the refrigerated space is given by:

$$Q_e = \dot{m} (h_{in} - h_{out}) \quad \text{Equation (2.5)}$$

where Q_e is the heating capacity for the evaporator, \dot{m} is the mass flow rate in to the evaporator, h_{in} and h_{out} is the enthalpy in the inlet and outlet of the evaporator.

2.1.4 Notation

Changing the heating capacity of the evaporator is due to the varying of the mass flow rate of the refrigerant. Which is effected by changing the rotational speed of the compressor, so a proportional control system can be applied on this plant. The control will link the frequency and the temperature of the refrigerated space, until the actual temperature meets the required value of temperature. The controller adjusts the frequency to compensate the heat loss and keep the consistency of the temperature. When any change comes from the surrounding, the controller adjusted frequency and compensate this change. Compensation and consistency of the temperature is very important to refrigeration system and is considered one of the main indexes of the cycle performance. A huge disadvantage of the conventional ON / OFF control system is the variation in temperature when a

new load is introduced to the system. In the present work, Compensation and consistency is considered one of the main objective of this project.

2.2 Controlling system

The thermal load for the refrigerated space is continuously varies with time, so the control system must be closed loop control system to be adjusts with the change of the thermal load. The design of any control system for the refrigeration cycle must have a closed loop configuration. With the conventional on / off controller in closed loop configuration a mechanical thermostat is used. But with a pre-sited two values of temperature for ON period and another value for OFF period. In the proposed scheme, only the desired value of the temperature is enough to be fed to the close loop control system. The controller compares the desired value with measured value by the temperature sensor to adjust the input frequency. Figure 2.3 shows in detail the closed loop control system schematic.

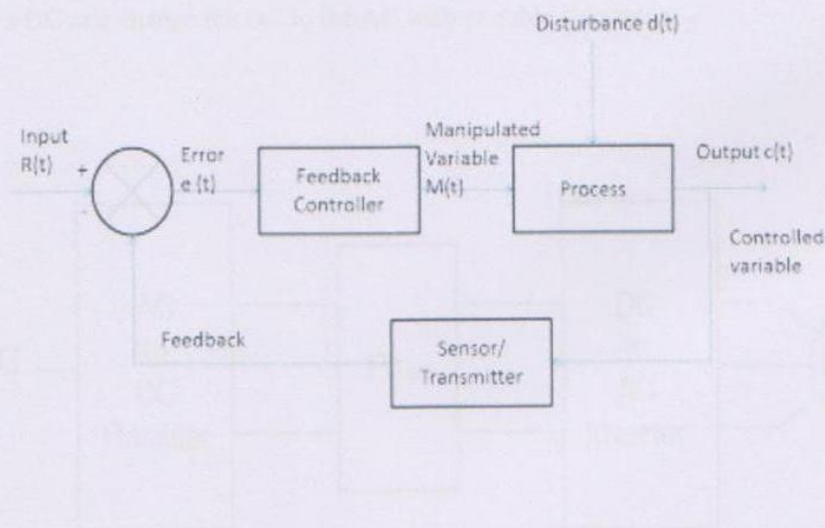

Figure 2.3 closed loop control system diagram.

As shown in Figure 2.3 the temperature is feed-back through the closed loop control system to the input in order for the controller to adjust the error in the temperature value. The disturbance that come from the simultaneous change in the thermal load will change the temperature measured by the sensor changing the error value continually. This change will be spotted by the closed loop control system and the controller will adjust the input to meet the desired output.

2.3 Variable frequency drive

Control system design starting from what is to be controlled and how to controlled it. In this work, the system to be controlled is a simple refrigeration cycle, and it is controlled by changing the frequency fed into the compressor to control the temperature. The device that is utilized in this work to change the input frequency for the AC motor is called variable frequency drive (VFD). VFD is known by its ability to changing the frequency. Also, VFD is controlled device where output frequency can be adjusted electrically and manually. Which makes it vary suitable device for the suggested control loop. In Figure 2.4 the principle of work for variable frequency drive is shown. VFD changes the commercial AC power supply to a DC power, then smooth the pulsation included in the DC and change the DC to the AC with variable frequency.

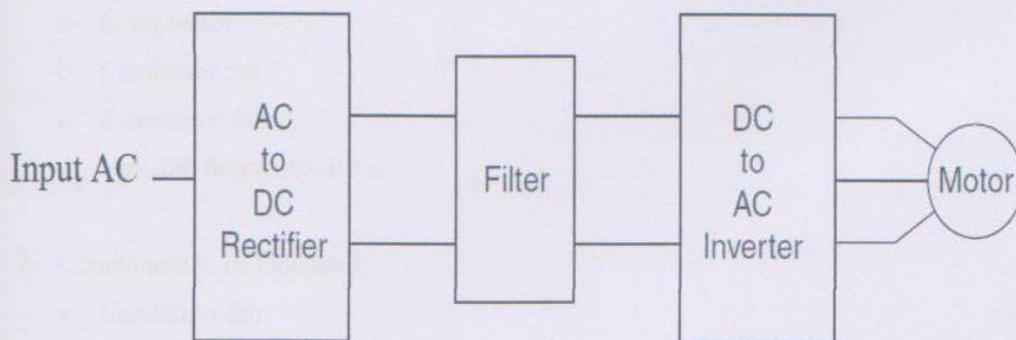

Figure 2.4 Variable frequency drive working principle.

2.3.1 Variable frequency drive controller

Commercial VFDs are equipped with analog control ports attached on their body. Through these control ports the output voltage, frequency can be adjusted. The controller will be connected to the analog input ports in order to calibrate the frequency of the output voltage with a value of frequency which is mapped to a desired value of temperature. The measured value of the temperature is fed to the controller which is in this case is Arduino board programed by using LabVIEW software. The monitoring system is connected with Arduino in order to view what happened to the temperature value in the refrigeration space and to report the errors whenever occurred.

2.4 Control circuit

The control circuit for the any system must satisfy a three main attributes for a controller. The three attributes are the components to be controlled, the priority of component to be operated, and the components to be protected. These components is listed below:

1- Component to be controlled:

- a- Compressor
- b- Condenser fan
- c- Evaporator fan
- d- Variable frequency drive

2- Component to be Operated:

- a- Condenser fan
- b- Variable frequency drive
- c- Compressor
- d- Evaporator fan

3- Component to be Protected:

- a- Compressor
- b- Condenser fan
- c- Evaporator fan

The operation of the cycle indicates that the first motor to run in the cycle is the condenser fan motor which is not driven by the variable frequency drive that's to decrease the condenser pipe temperature and increase forested heat transfer by convection with the surrounding, this way comes from the Carnot coefficient of performance (COP_{Carnot}) for the refrigeration cycle:

$$COP_{Carnot} = \frac{T_L}{T_H - T_L} \quad \text{Equation (2.6)}$$

where T_L is the evaporator temperature and T_H is the condenser temperature, so by decreasing the condenser temperature the coefficient of performance for the refrigeration cycle will increase.

Another reason for not using the VFD to drive the condenser fan motor is to keep it at high speed. Since, the pressure is approximately the same in the condenser for both controllers-ON / OFF temperature control system and the new control system. In order to prevent high pressure at the condenser which is represented by the high pressure side at the outlet of the compressor; the condenser fan motor must operate at the same speed in both controllers. See Figure 3.6 and Figure 3.12 that show the pressure in the inlet and the outlet of the compressor when use both conventional ON / OFF temperature control system and PID control system.

Evaporator and compressor motor drive by variable frequency drive. But for the first run they powered directly from the power source. Then the on delay timer switches between the power source and the VFD, that's in order to protect variable frequency drive from overloud and high starting currant consumed by the compressor.

Figure 2.5 shows the control circuit drawn using Automation Studio Software. The circuit is powered using a stepdown transformer (240V/24V), the first line contains the normally open switch S1 that switches the circuit ON and the normally close S2 that switches the circuit OFF. S1 and S2 are connected to contactor KM1. The second line is the self-holding line continue 1 pole contact from contactor KM1. Line number three is the condenser fan motor line continue a normally close contact F1 to protect the motor from overload. Line three also contain the contactor KM2 to control the condenser motor. The fourth line is used to trigger the on delay timer KA1. The last two line contain KM3 contactor to control the compressor and condenser fan for the first operation time, then the timer contact KA1 is used to switch between KM3 and KM4, to swathes the source and the VFD respectively. The over load normally close contacts F2 and F3 is used to protect the compressor and condenser fan motor from overload.

2.5 Power circuit

Figure 2.6 shows the power circuit for the simple refrigeration cycle simulated in Automation Studio Software. Motors M1, M2 and M3 represent the the condenser fan motor, evaporator fan motor, and compressor motor respectively, all motors are thermally protected from the overload by using the overload relays F1, F2 and F3.

Variable frequency drive start to drive the condenser fan and compressor motors after the on delay timer change the normally open contact group KM4 from open to close, while simultaneously the contact group KM 3 will be open and the driver for two motors will be the variable frequency drive.

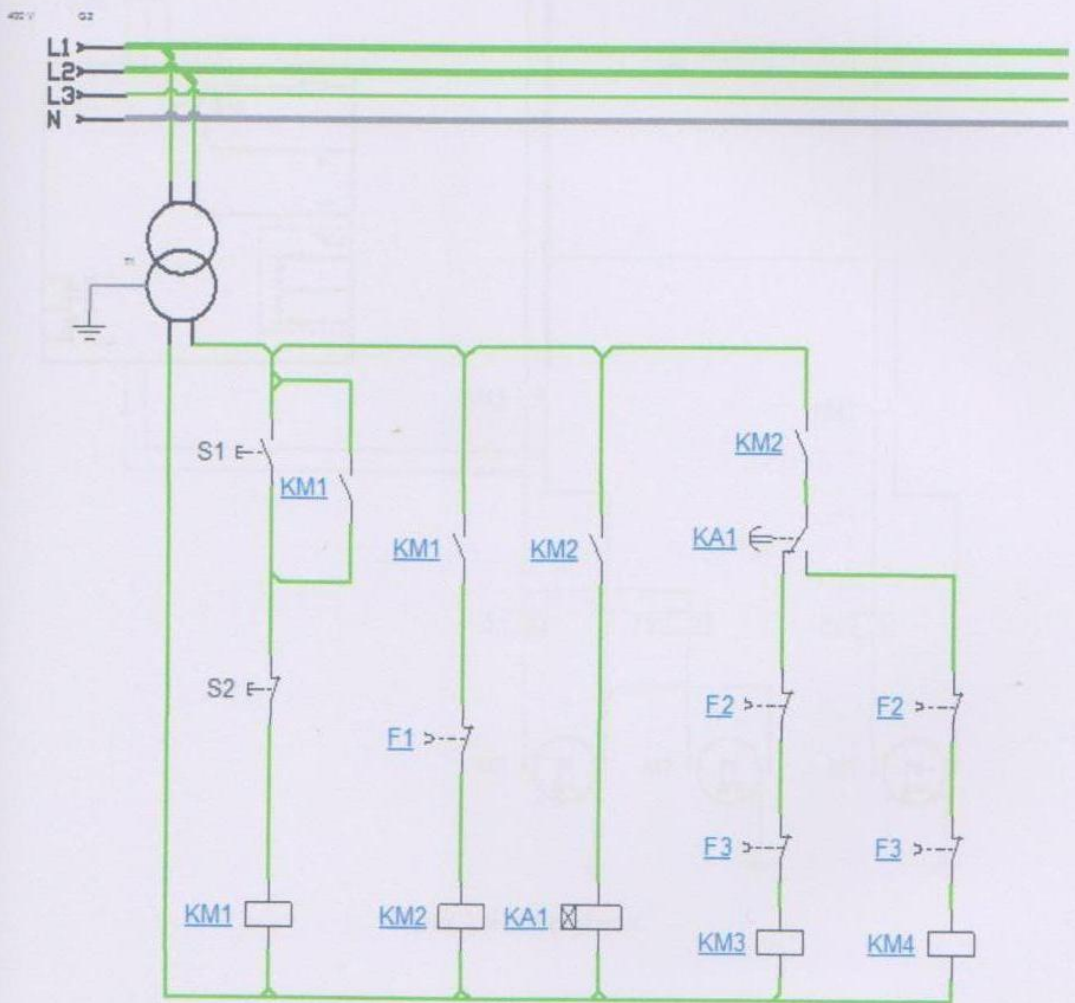

Figure 2.5 Control circuit.

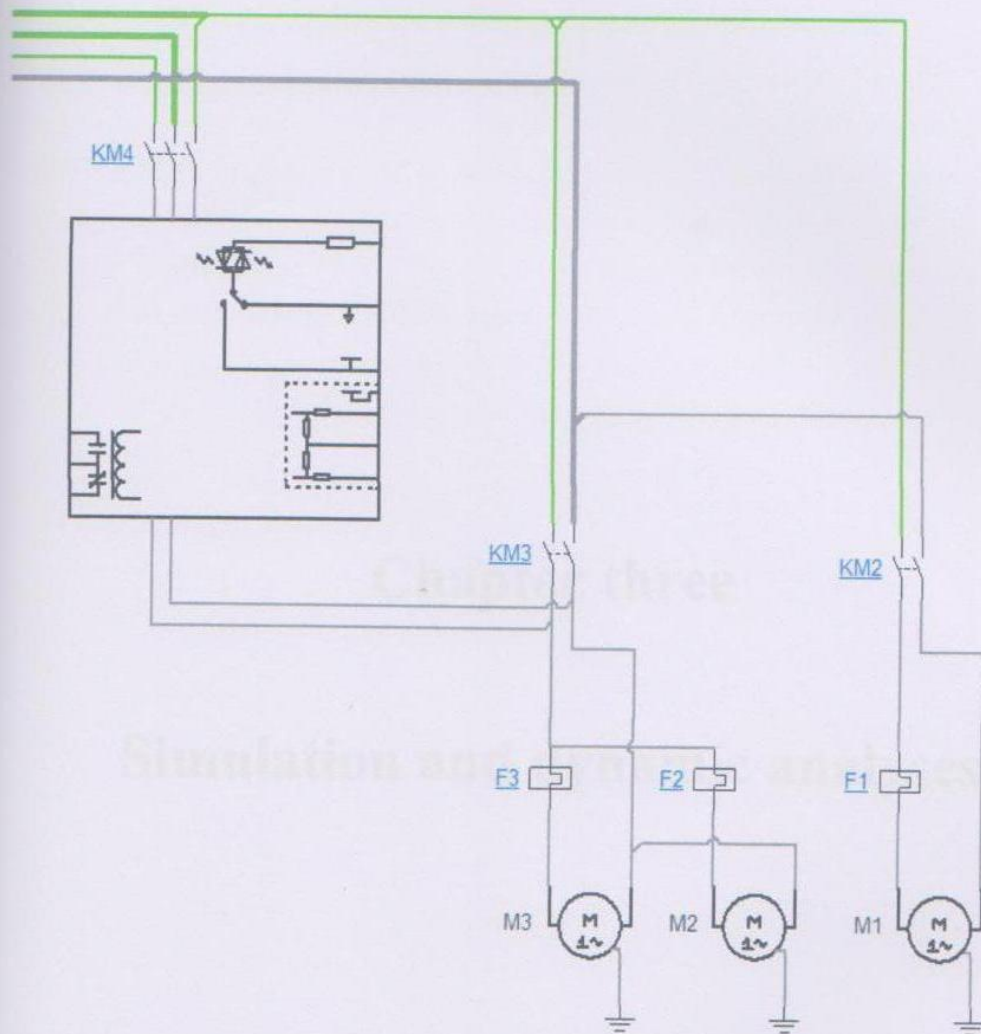

Figure 2.6 Power circuit.

Simulation and analysis

The simulation analysis for the system is performed using the state space method. The state space method is a powerful tool for analyzing the dynamic behavior of a system. It involves representing the system as a set of first-order differential equations. The state space method is used to analyze the stability, controllability, and observability of a system. The state space method is also used to design controllers for a system. The state space method is a powerful tool for analyzing the dynamic behavior of a system.

Chapter three

Simulation and dynamic analyses



Figure 3.1: Block diagram of a control system

3.1 Simulation model

The simulation models for the vapor-compression refrigeration cycle has been done using two-phase fluid components. The compressor drives the R-134a refrigerant through a condenser, an expansion valve, and an evaporator. The hot gas leaving the compressor condenses in the condenser via heat transfer to the environment. The pressure drops as the refrigerant passes through the expansion valve. The drop in pressure lowers the saturation temperature of the refrigerant. This enables it to boil in the evaporator as it absorbs heat from the refrigeration space. The refrigerant then returns to the compressor to repeat the cycle. The controller turns the compressor on and off to maintain the refrigerator compartment temperature within a band around the desired temperature.

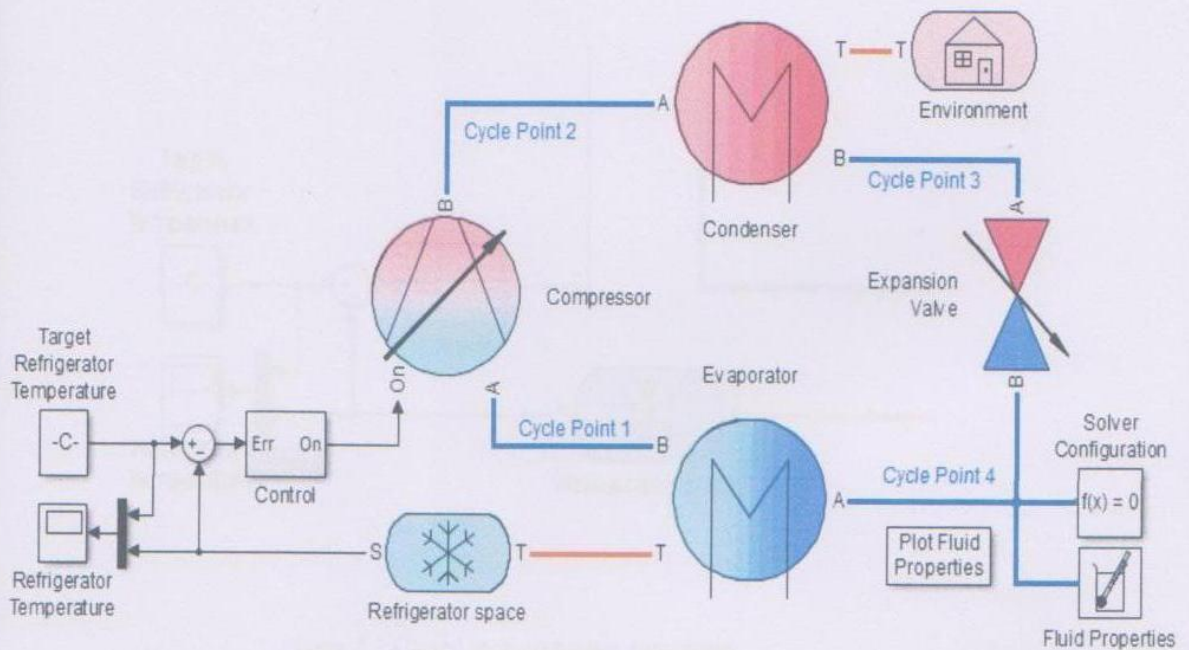

Figure 3.1 Simple vapor-compression refrigeration cycle model.

The models simulate the simple vapor-compression refrigeration cycle using MATLAB Simulink software as shown in figure 3.1. In the first step the simulation operates on an ON / OFF controller to operate the cycle. When the temperature reaches the minimum set point the controller switches the cycle OFF. And when the temperature reaches the maximum set point the controller switches the cycle ON. The relay is used to maintain the temperature of the refrigeration space around the required value of temperature. The close loop provides the controller with the temperature of the refrigeration space and the controller compares it with the required value of temperature then decide to ON or OFF the cycle.

3.1.1 control system

The feedback of the close loop control system is a temperature sensor as shown in figure 3.2 that feed the controller with the actual temperature of the refrigeration space. Then the subtraction node finds the maximum error in the temperature and send the error to the controller.

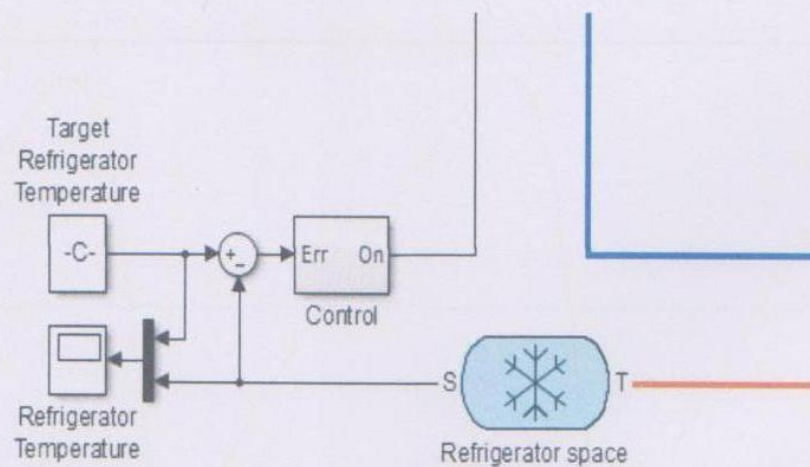

Figure 3.2 Closed loop controller simulation.

The controller contains a relay. The relays input is the error that come from the subtraction node and the relay output is the signal to switches the compressor ON or OFF depend on the sign of the error as shown on figure 3.3.



Figure 3.3 Controller simulation.

Using the MATLAB Simulink to plot the output response for the temperature with the time as shown in the figure 3.4. The y-axis represents the temperature in Kalvin and the x-axis represents the time in seconds. The blue line represents the required value of the temperature and the orange line represents the actual temperature of the refrigeration space.

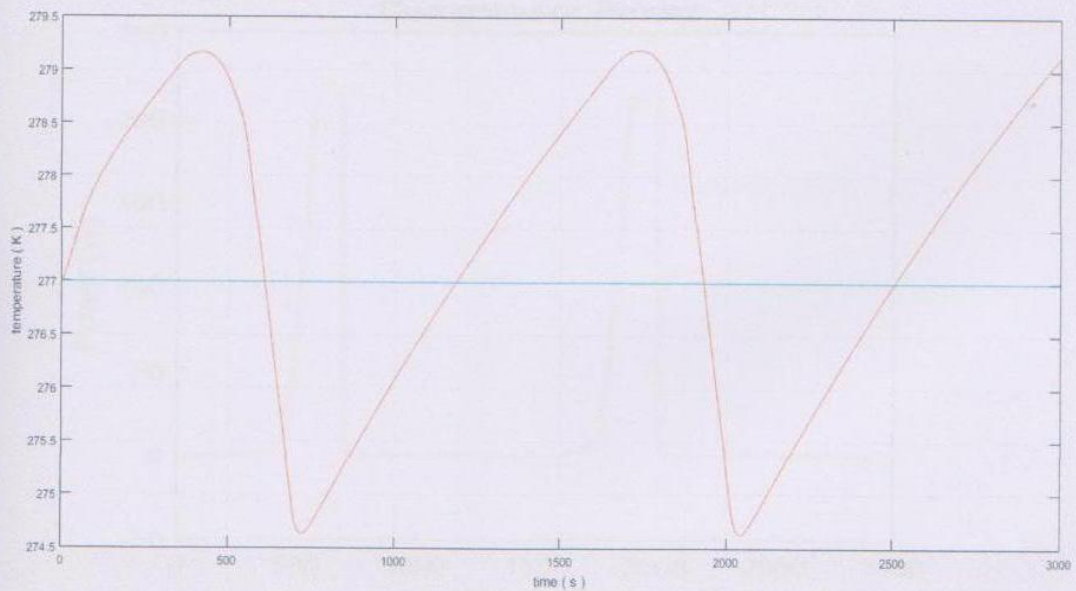

Figure 3.4 Response for the temperature verses time.

As shown in figure 3.4 the actual value of temperature is not constant and the oscillation from the actual value is large, that's because of using a conventional ON / OFF controller the difference between the actual value of temperature and the required value change with the time and we can't set the temperature on a one value, so the compressor switches ON when the actual value of temperature reaches the minimum sit value and the compressor switches OFF when the actual value of temperature reaches the maximum sit value of temperature. By using this controller, the mechanical part and the electrical of the compressor will damage because of switches ON and OFF the compressor and the compressor will always run in the maximum speed.

3.1.2 compressor power

The power consumption is another major factor to be studied. The compressor consumes high power while it's operating in each time and run on maximum speed. Figure 3.5 show the theoretical power consumed with the time when use the conventional ON /OFF controller.

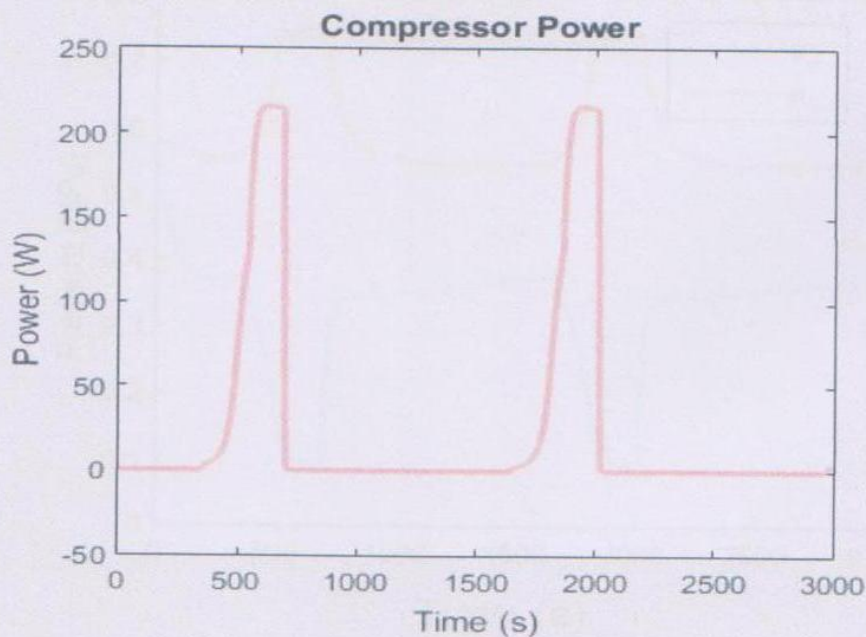

Figure 3.5 Compressor power verses time.

The power consumed by the compressor reach high value when the compressor runs ON and then back to zero. The power consumed by the compressor shown in figure 3.5 is when use the conventional ON / OFF controller.

3.1.3 compressor pressure

The compressor pressure in the inlet and the outlet versus time represent that the compressor inlet pressure reaches the minimum value when the compressor switches ON and the compressor pressure in the outlet reaches the maximum value when the compressor switches ON as shown in figure 3.6. when the compressor switches OFF again the pressure in the inlet and the outlet back again to the initial value, so in both the power that feed the compressor changes the pressure in the outlet and the inlet. In this case the high power consumed by the compressor changes the pressure. All this is occurring when conventional ON / OFF controller is used.

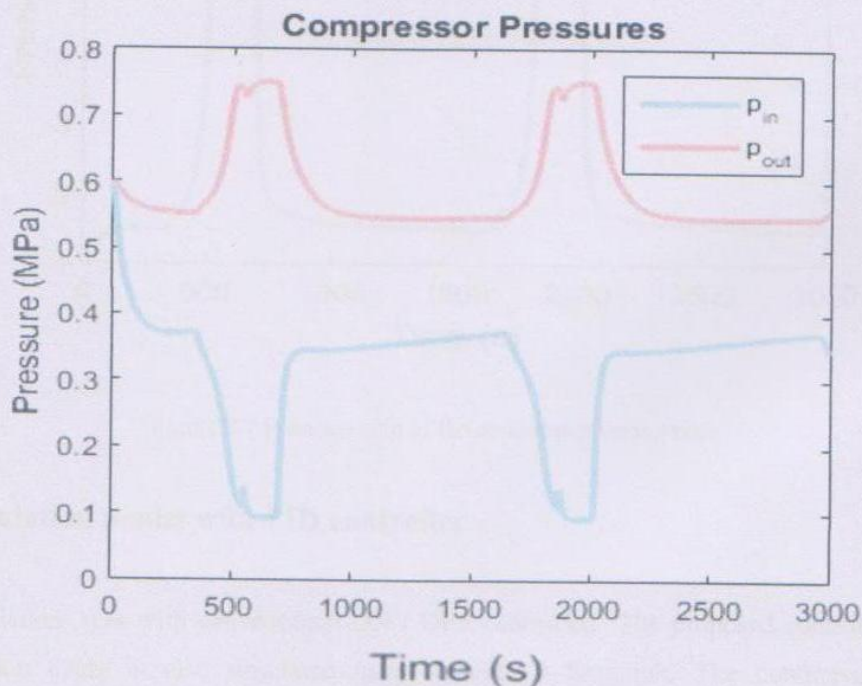

Figure 3.6 Pressure in the inlet and the outlet of the compressor versus time.

3.1.4 pressure ratio

The pressure ratio defined as the high pressure of the cycle divided on the low pressure of the cycle. Figure 3.7 show that the pressure reaches the high value when the compressor switches ON and then back to initial value.

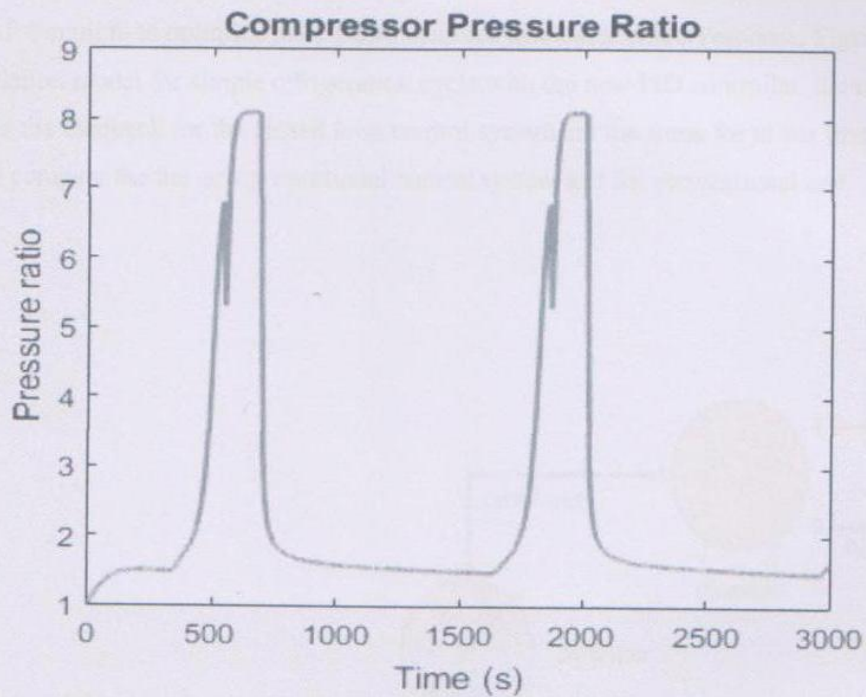

Figure 3.7 Pressure ratio of the compressor versus time.

3.2 Simulation model with PID controller

The simulation was with conventional ON / OFF controller. The proposed controller for the refrigeration cycle is also simulated using MATLAB Simulink. The compressor power, compressor inlet and outlet pressure and the compression ratio is plotted versus time. The simulation model clarifies the principle operation of the suggested controller and to estimate

improvement when using the proportional control system to reduce the power consumption by the compressor. Also, to estimate the increment in the coefficient of performance of the refrigeration cycle. The reduction in power consumption is not the only advantage of using the new proportional controller, but also the high starting power consumed by the compressor decrease the life expectancy, this issue is solved using unconventional controller for the compressor and protect the compressor from the high and low pressure. The new controller simulation model is done on the same refrigeration cycle but using the proportional, integral and derivative PID controlling system. Using the auto tuning functionality for the PID controller to find the parameters k_i , k_p and k_d in MATLAB Simulink to optimize these parameters for fast and accurate response. Figure 3.8 show the simulation model for simple refrigeration cycle with the new PID controller. the refrigeration cycle and the feedback for the closed loop control system are the same for to the first simulation model to compare the the new proportional control system and the conventional one.

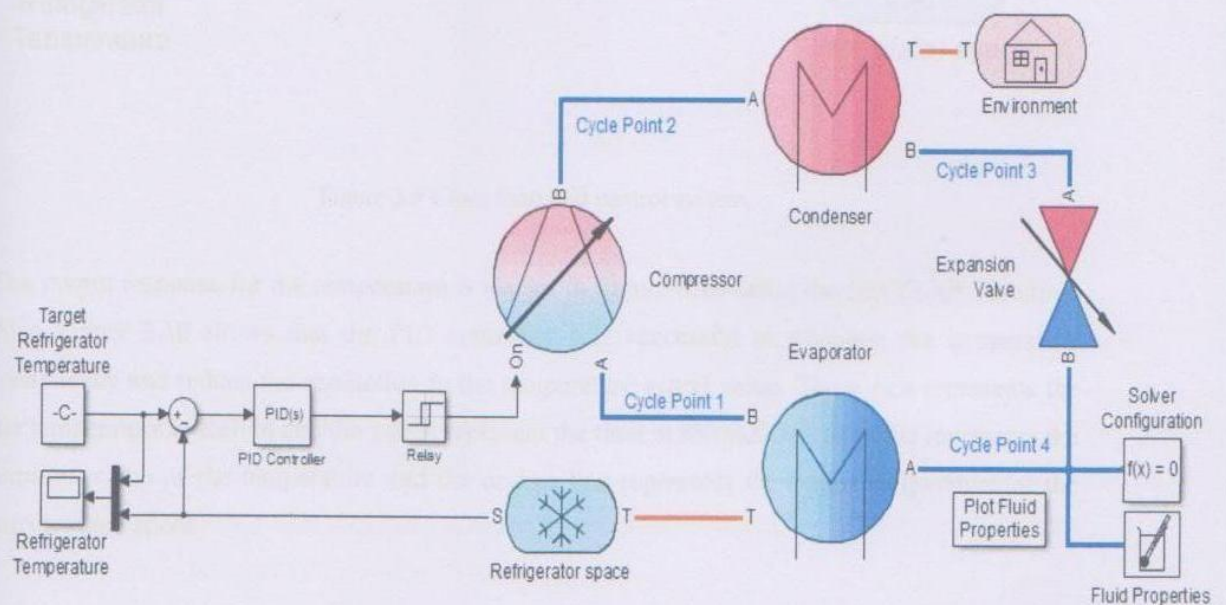

Figure 3.8 Simple vapor compression refrigeration cycle using the new PID control system.

3.2.1 control system

A close loop control system controller simulation model using PID instead of the conventional ON / OFF controller is done. the controller controls the power consumption by the compressor to be appropriate with the thermal load in the refrigeration space. Figure 3.9 show the PID control system for the refrigeration cycle and the feedback temperature sensor for the close loop control system.

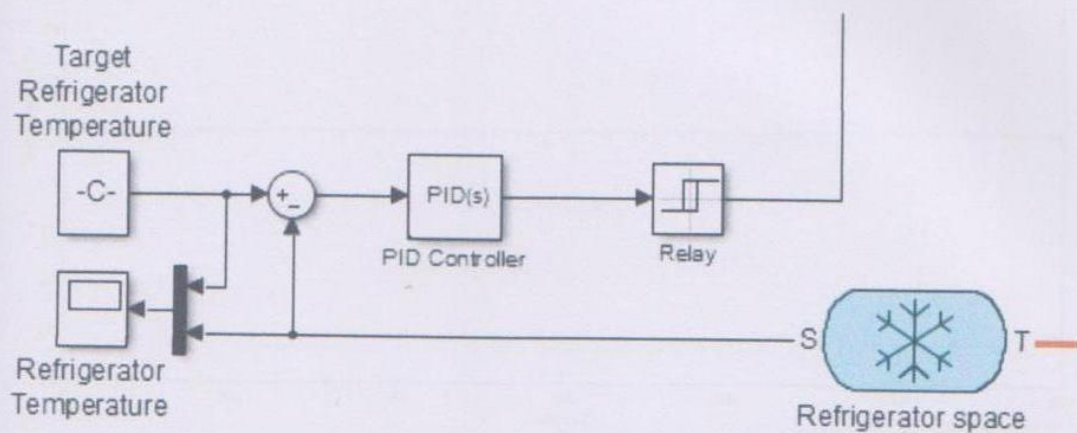

Figure 3.9 Close loop PID control system.

The output response for the temperature is shown in Figure 3.10 using the MATLAB Simulink. Also Figure 3.10 shows that the PID controller was successful to maintain the temperature consistency and reduce the oscillation in the temperature actual value. The y-axis represents the the temperature in Kalvin and the x-axis represent the time in seconds, the blue line represents the required value of the temperature and the orange line represents the actual temperature of the refrigeration space.

An overshoot of the value of the actual temperature at the starting represent the transient response for the PID controller. And the steady state response was obtained in a short time. The oscillation

in the actual temperature value was due to varying in the thermal load in the refrigeration space. The controller keeps temperature consistency in acceptable range and the compressor input power amount is justified for the current thermal load.

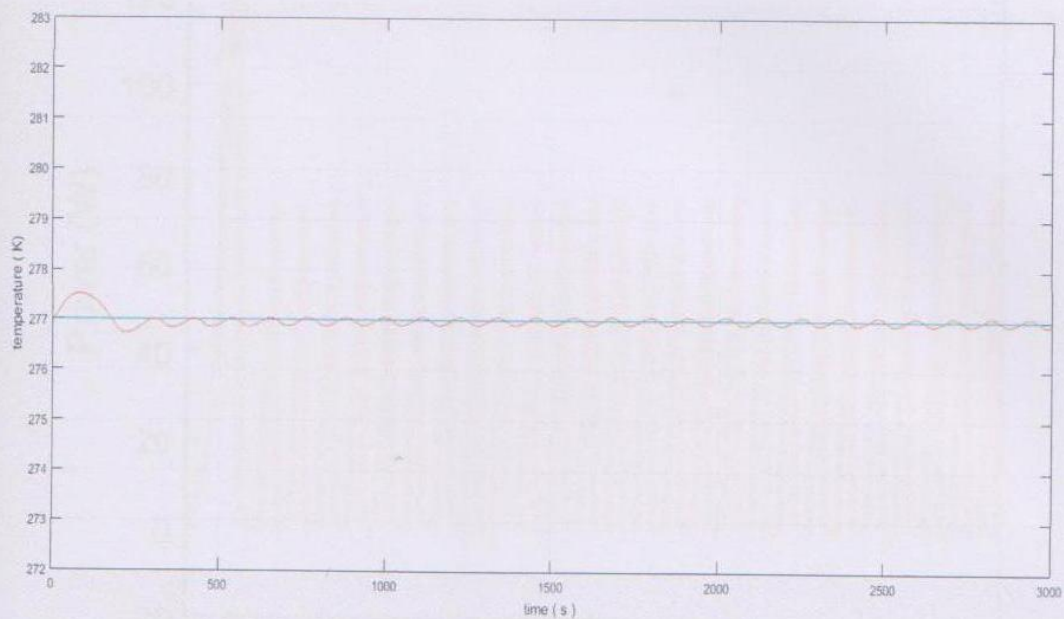

Figure 3.10 Response for the temperature versus time when using PID control system.

3.2.2 compressor power

With the new PID controller the power consumed by the compressor is approximately reduced by 20 % as shown in Figure 3.11 that represent the power in to the compressor versus time, so with the new controller the coefficient of performance for the refrigeration cycle will increase by reducing the power consumed by the compressor.

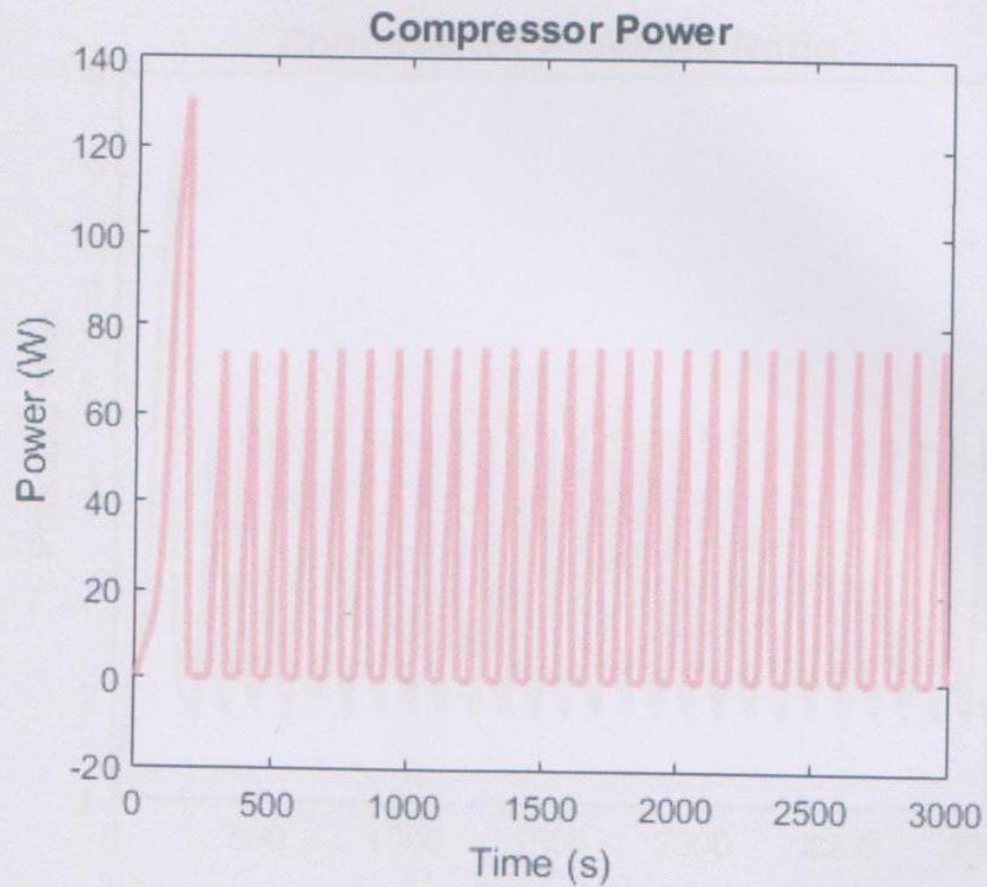

Figure 3.11 The power consumes by the compressor when use the PID control system.

3.2.3 pressure ratio

Another advantage when using the PID control system is the pressure ratio. Figure 3.11 shows that the pressure ratio when using the new control system is small value which means that we can replace the compressor with another one having less compression ratio and consumes less power to operate the refrigeration cycle. But the oscillation in the compression ratio in the study state response as shown in Figure 3.12 is due to the change in the thermal load in the refrigeration space.

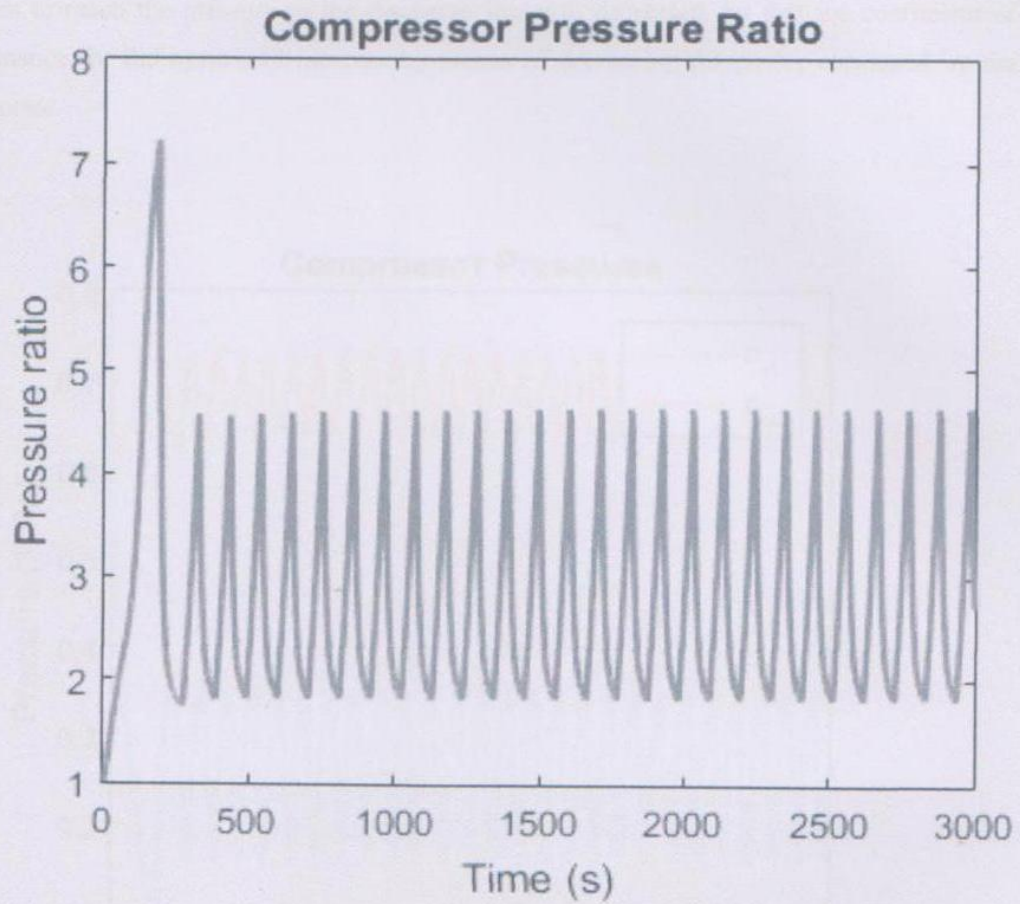

Figure 3.12 The compression ratio for the compressor when using The PID control system.

3.2.4 Compressor pressure

The compressor pressure in the inlet and the outlet was plotted versus time as shown in Figure 3.13. An increasing in the pressure into the compressor when using the PID controller and the similarity for the pressure out from the compressor when using the conventional ON / OFF control system and PID control system represent all the benefit for using this control system. The

compressor suction line pressure is high so the power consumes by the compressor to increase the pressure to reach the pressure in the discharge line will decreased, by that the coefficient of performance for the cycle will increase by means of decreasing the power consumed by the compressor.

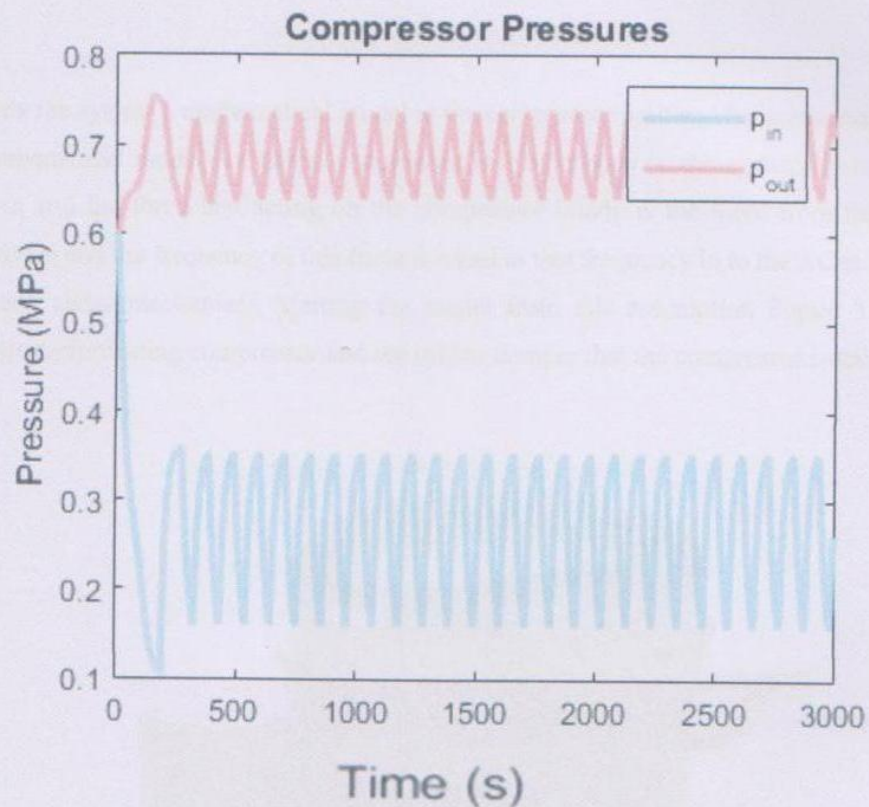

Figure 3.13 Pressure in the inlet and the outlet of the compressor versus time when using PID controller.

3.3 Dynamic analysis

Working with the mechanical system needs dynamic analyses to analyze the behavior of the mechanical system, the refrigeration cycle one of the mechanical system that represent a

mechanical system in each component, the aim of this project is to control temperature by changing the speed of the rotation of the compressor motor to meet the thermal load and cover the loss in the refrigeration cycle and in order to change the speed of rotation of the AC motor the frequency in to the motor must be change the speed of rotation will changed, so the frequency that causes the dynamic motion (vibration) to the mechanical system which is compressor will change in a range to be appropriate with the required mass flow rate out from the compressor.

To study the system a mathematical model to the compressor built and the assumption to simplify the mathematical model is that the compressor is a rigid body so the system is single degree of freedom and the force that acting on the compressor buddy is the force from the crank slider mechanism and the frequency of this force is equal to that frequency in to the AC motor that drive the crank slider mechanism. Starting the model from this assumption Figure 3.14 show the hermetic reciprocating compressor and the rubber damper that the compressor installing on it.



Figure 3.14 Hermetic reciprocating compressor.

The free-body diagrams for the compressor as shown in Figure 3.15 the four springs and four dampers. Assuming the four springs and dampers are symmetric and the center of mass is in the middle, so the four spring displacement and the four damper velocity are the same and to find the equivalent spring mass damper system for the compressor.

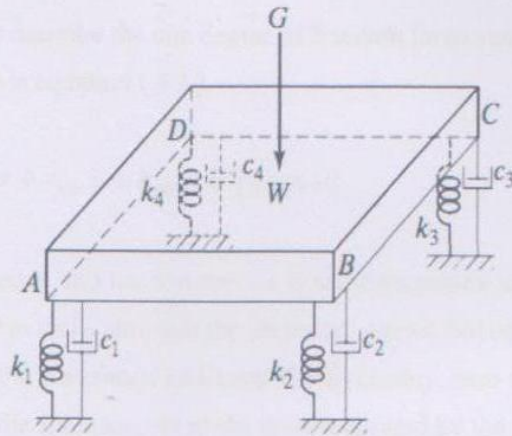

Figure 3.15 Compressor modeling.

In case of parallel springs and dampers equivalent are equal to their summation so the system equivalent is spring mass damper system as shown in Figure 3.16.

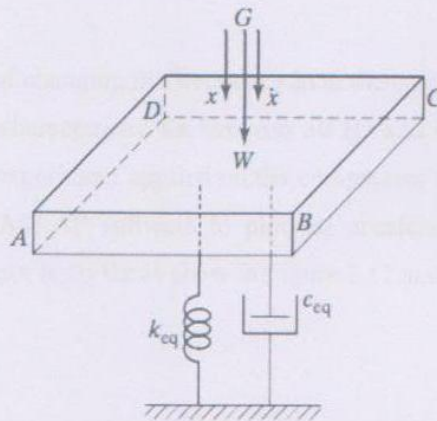

Figure 3.16 Compressor modeling equivalent.

The equivalent spring and damper as in equation (3.1) and (3.2) respectively.

$$k_{eq} = k_1 + k_2 + k_3 + k_4 \quad \text{Equation (3.1)}$$

$$c_{eq} = c_1 + c_2 + c_3 + c_4 \quad \text{Equation (3.2)}$$

The modeling equation that describe the one degree of freedom force veneration with damping and under a harmonic force is equation (3.3).

$$m\ddot{x} + c_{eq} \dot{x} + k_{eq} x = F_0 \cos \omega t \quad \text{Equation (3.3)}$$

By assuming that the frequency into the compressor is same frequency to the force that cause the vibration to the system, and to make sure that the frequency ratio is not equal to one to prevent the system from filler due to the resonance and keep the frequency ratio in acceptable value, the frequency ratio is equal to the frequency in to the system divided by the natural frequency of the system. From the solution of the equation of motion for the compressor model the natural frequency is equal to the square root of the k_{eq} divided by mass of the system as shown in equation (3.4).

$$\omega_n = \sqrt{\frac{k_{eq}}{m}} \quad \text{Equation (3.4)}$$

In order to study the effect of changing the frequency in to the compressor a range of frequencies depend on the compressor characteristic set between 30 Hz and 60 Hz. An experiment on the system had been done, the experiment applied on the compressor to measure the acceleration of the vibration. By using MATLAB software to plot the acceleration with the time when the frequency in to the compressor is 50 Hz as show in Figure 3.17 and when the frequency 30 Hz as show in Figure 3.18.

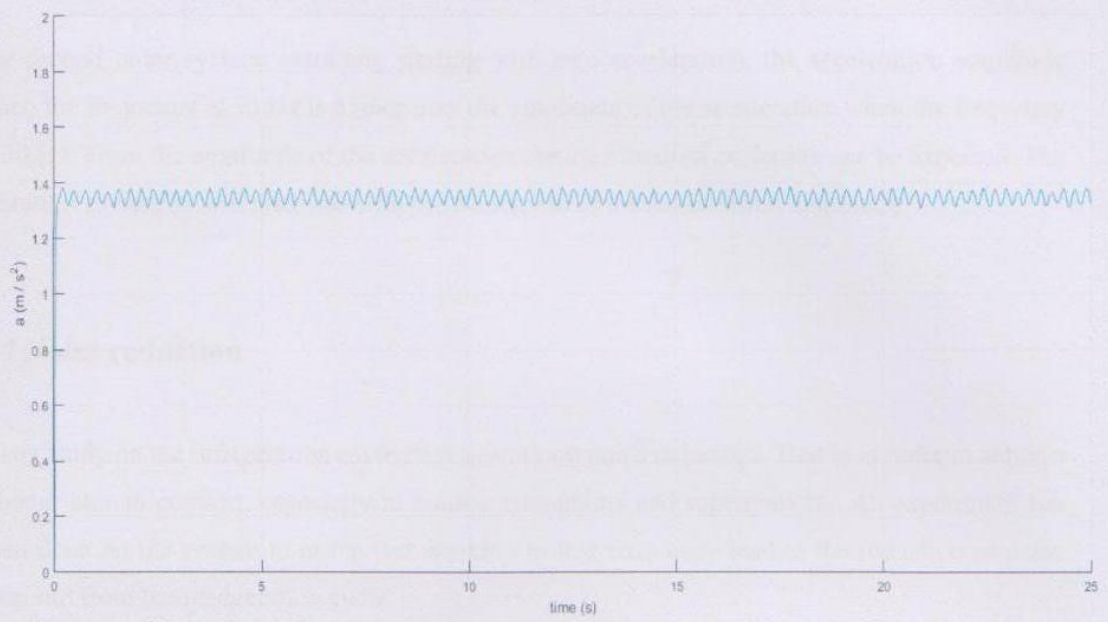

Figure 3.17 Acceleration with time when the frequency is 50 Hz.

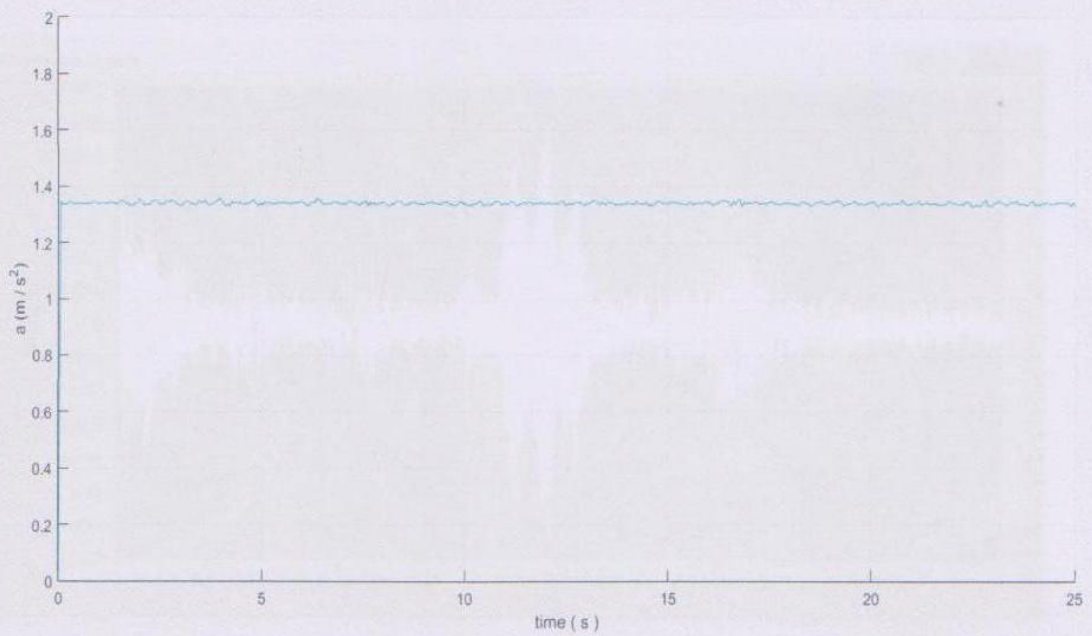

Figure 3.18 Acceleration with time when the frequency is 30 Hz.

For second order system, assuming starting with zero acceleration, the acceleration amplitude when the frequency is 50 Hz is higher than the amplitude of the acceleration when the frequency is 30 Hz. From the amplitude of the acceleration the the vibration excitation can be expected. The vibration excitation will decrease with the decrement of the acceleration amplitude.

3.4 Noise reduction

Many study on the refrigeration cycle start to work on noise reduction. That is in order to achieve a better human comfort, especially in houses, restaurants and supermarkets. An experiment has been done on the system to prove that working in low frequency lead to the reduction of noise level out from the refrigeration cycle.

The experiment done using LabVIEW Software and library of voice recognition. Figure 3.19 and figure 3.20 show the different noise amplitudes at the frequency 50 Hz and 30 Hz. The amplitude in case of 30 Hz is lower than the amplitude in case of 50 Hz.

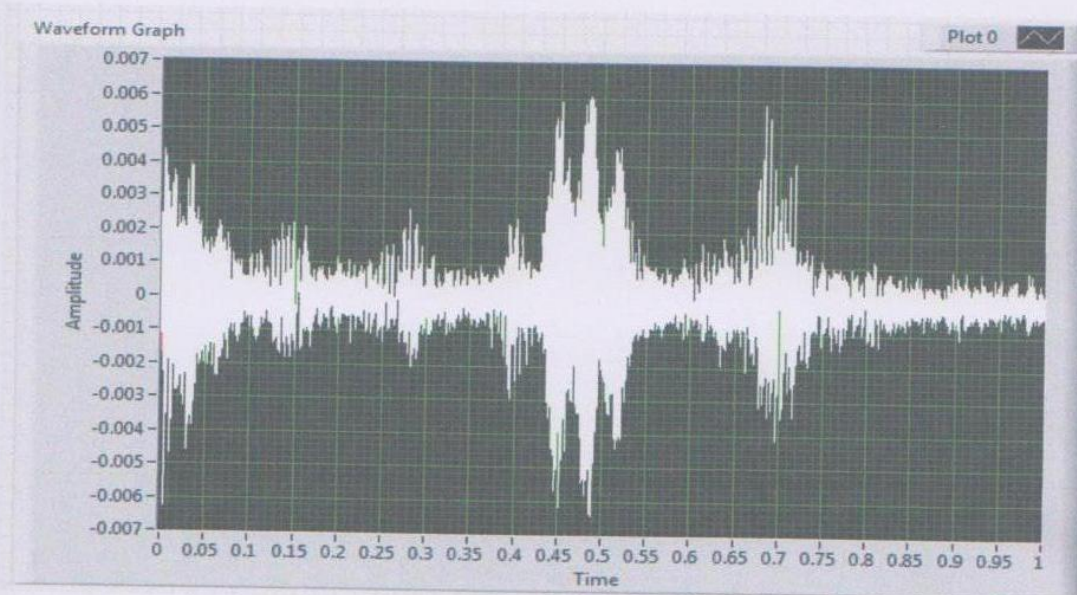

Figure 3.19 Amplitude of the voice versus time when the frequency is 50 Hz.

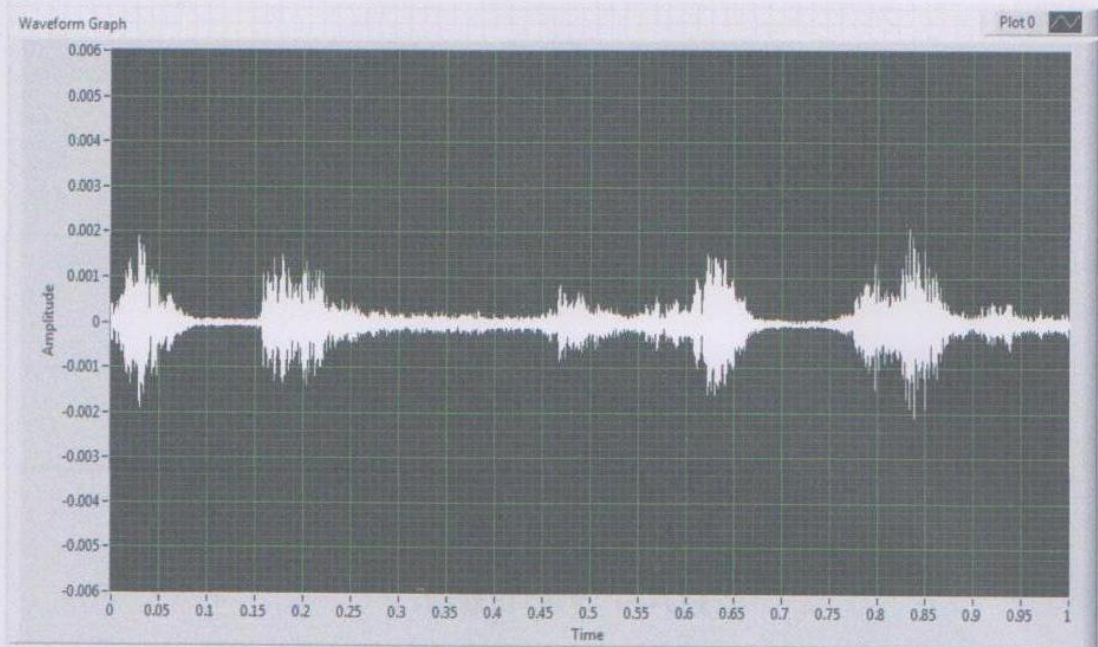

Figure 3.20 Amplitude of the voice versus time when the frequency is 30 Hz.

4.1 Introduction

In this chapter a deep insight is given into the design and implementation of a control system. The main objective is to provide a clear and concise overview of the design process, from the initial requirements to the final implementation. The chapter is divided into two main parts: the first part deals with the design of the control system, and the second part deals with the implementation of the control system on a digital computer.

Chapter four

System identification and monitoring system

Figure 4.1: The control system

The control system is designed to regulate the system output to a desired value. The system is modeled as a transfer function, and the control system is designed using the root locus method. The control system is implemented on a digital computer, and the results are compared with the analytical results. The control system is designed to regulate the system output to a desired value, and the results are compared with the analytical results.

4.1 Introduction

In this chapter a deep insight to controller design is presented. To start with any controller design for a system first the system model is built and a description to the response of the system to any input is monitored. In this project figure 4.1 shows the input form a Micro-controller to the system which is a voltage signal and the output from the system which is the desired temperature. Also, the closed loop feedback is shown-which is in this case temperature sensor-. The plant consists of the simple refrigeration cycle associated with a variable frequency drive.

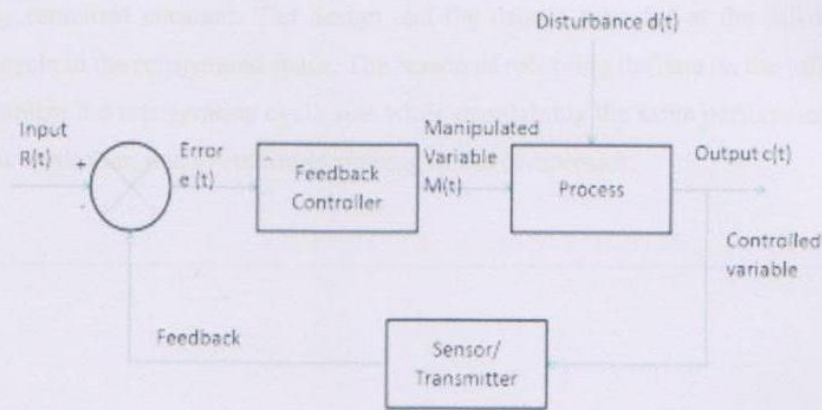

Figure 4.1 The close loop control system.

In the ON/OFF control system the same feedback used to enhance the controller to set the compressor ON or OFF at range around the desired temperature. The project aims to test the refrigeration cycle on both controllers. A touch screen with graphical user interface (GUI)is used to change the controller between the PID controller and the conventional ON/OFF controller. In the case when the user selects the conventional ON/OFF control system the controller output to the plant is high or low 5 volts, the compressor runs at 50 Hz when the input to the plant is high and turn OFF when the input to the plant is low. In the PID controller the output from the controller is between the zero volt and five volts, when the temperature in the refrigerated space is higher

than the desired value the output from controller increase. But when the temperature in the refrigerated space is higher than the desired value the output from controller decrease.

4.2 System identification

System identification is the first step in controlling the system. With the system identification a mathematical model is built to recognize how the system acts at known input. An experiment on the system has been made with a step input. Data for input, output and sampling time recorded and plot. Figure 4.2 show the output response for the temperature at a step input equal five volts. And at the X-axis the time. The data recorded until the temperature of the refrigerated space approximately remained constant. The design and the data is recorded at the full load of the refrigeration cycle in the refrigerated space. The reason of recording the data on the full load is the ability to minimize the refrigeration cycle size while maintaining the same performance with the use of the new controller, due to continues running of the compressor.

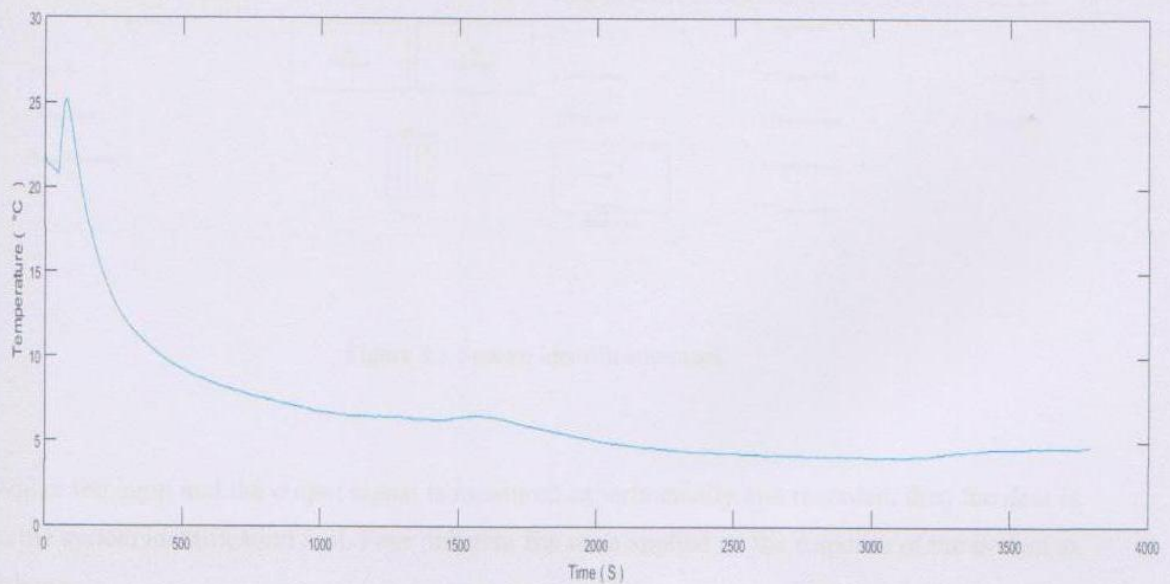

Figure 4.2 Response at step input.

Using MATLAB system identification tool to estimate the transfer function of the plant. The data measured for the input and the output with time. Figure 4.3 show the the system identification graphical user interface, which used to identify the system and estimate the transfer function. Four case have been taken. In each case the number of parameter, poles and zeroes change to get the best fit to the output response.

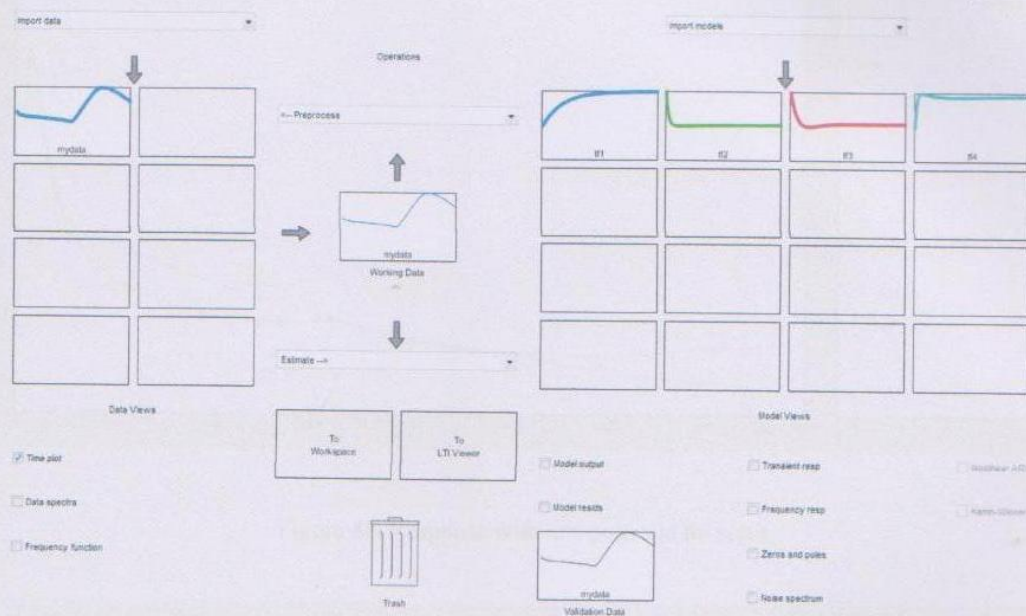

Figure 4.3 System identification tool.

Where the input and the output signal is measured experimentally and recorded, then the data in to the system identification tool. Four different fits were applied on the response of the system as follows.

- 1- With one pole and no zeros and the result was as shown in figure 4.4.
- 2- With two poles and one zero and the result was as shown in figure 4.5.

- 3- With three poles and two zeros and the result was as shown in figure 4.6.
- 4- With four poles and three zeros and the result was as shown in figure 4.7.

In each case the output response and the transfer function coincident with the experimental response was determined.

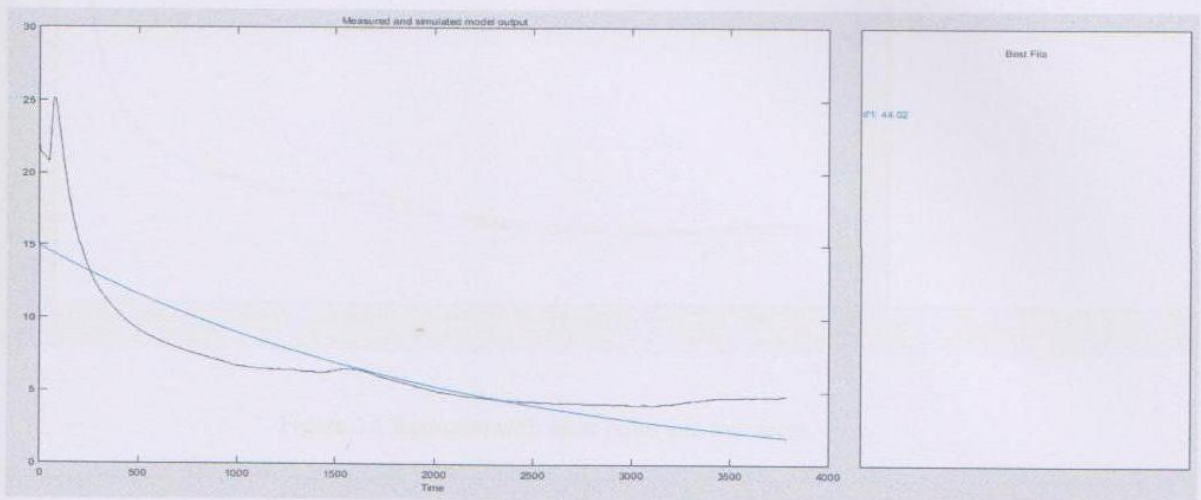

Figure 4.4 Response with one pole and no zeros.

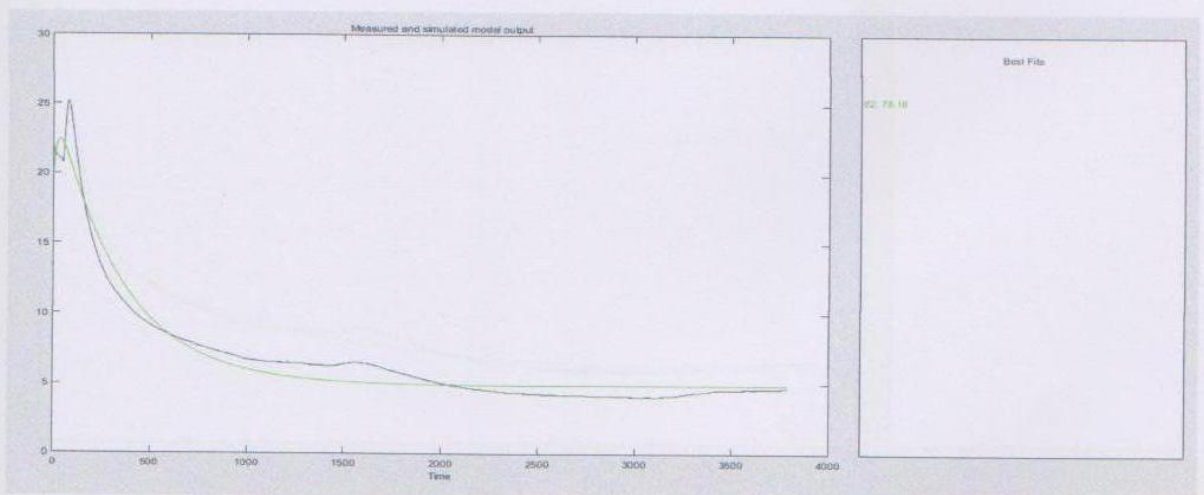

Figure 4.5 Response with two poles and one zero.

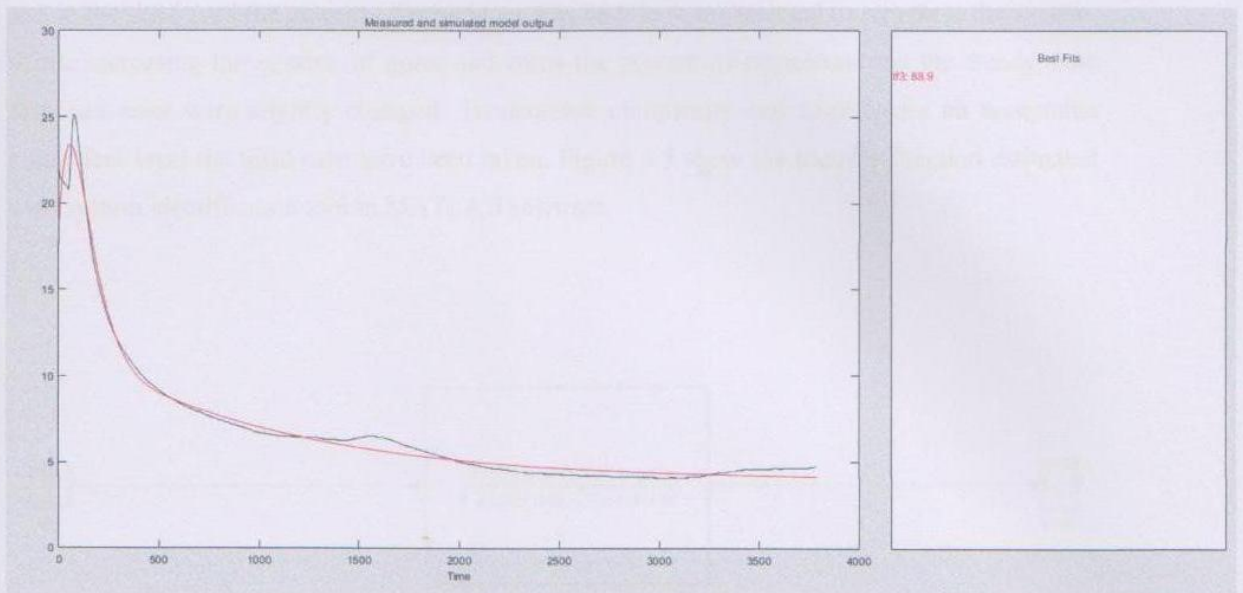

Figure 4.6 Response with three poles and two zeros.

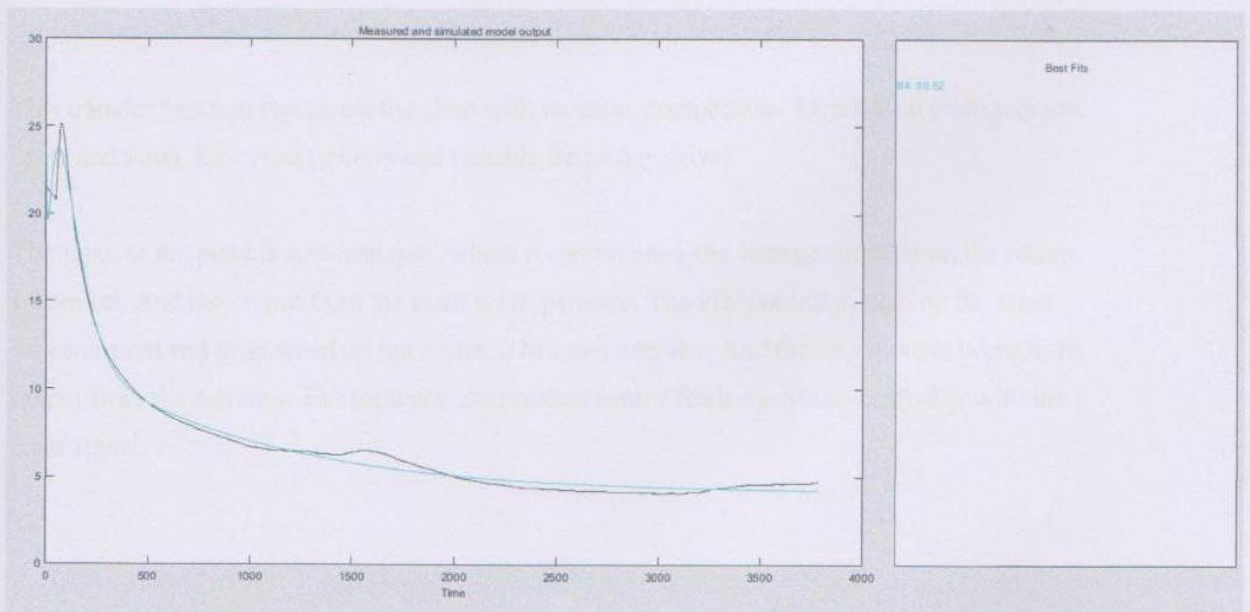

Figure 4.7 Response with four poles and three zeros.

From the four cases the last two fits the percent of coincident 88.9 % and 89.52 % respectively and in the third case the present of coincident was 88.9 % were selected to represent the system. While increasing the number of poles and zeros the present of coincident and the steady state response error were slightly changed. To decrease complexity and to maintain an acceptable coincident level the third case have been taken. Figure 4.8 show the transfer function estimated with system identification tool in MATLAB software.

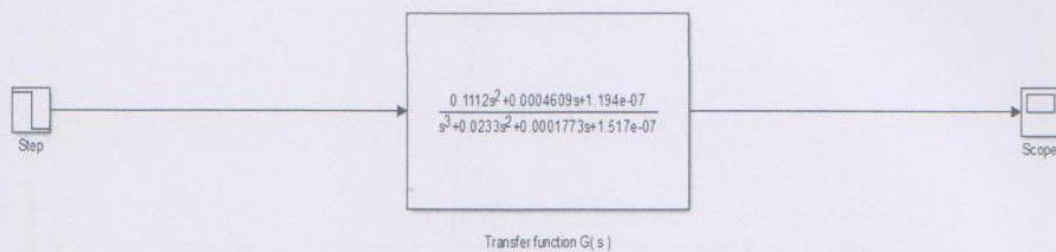

Figure 4.8 Transfer function

This transfer function represents the plant with its entire components. Mechanical (refrigeration cycle and fans). Electrical (motors and variable frequency drive).

The input to the plant is step response, which is representing the voltage output from the Micro-controller. And the output from the plant is temperature. The PID control system on the plant was analyzed and programed on the Arduino Micro-controller. And the step input is taken from output from the Adriano. The feedback temperature sensor feeds the Micro-controller with the error signal.

4.3 PID control system design

The design of the PID controller is done in MATLAB Simulink. Figure 4.9 shows the Root Locus plot for the system. It is noticed that the system is stable. The gain can be changed as we like and the system will remain stable.

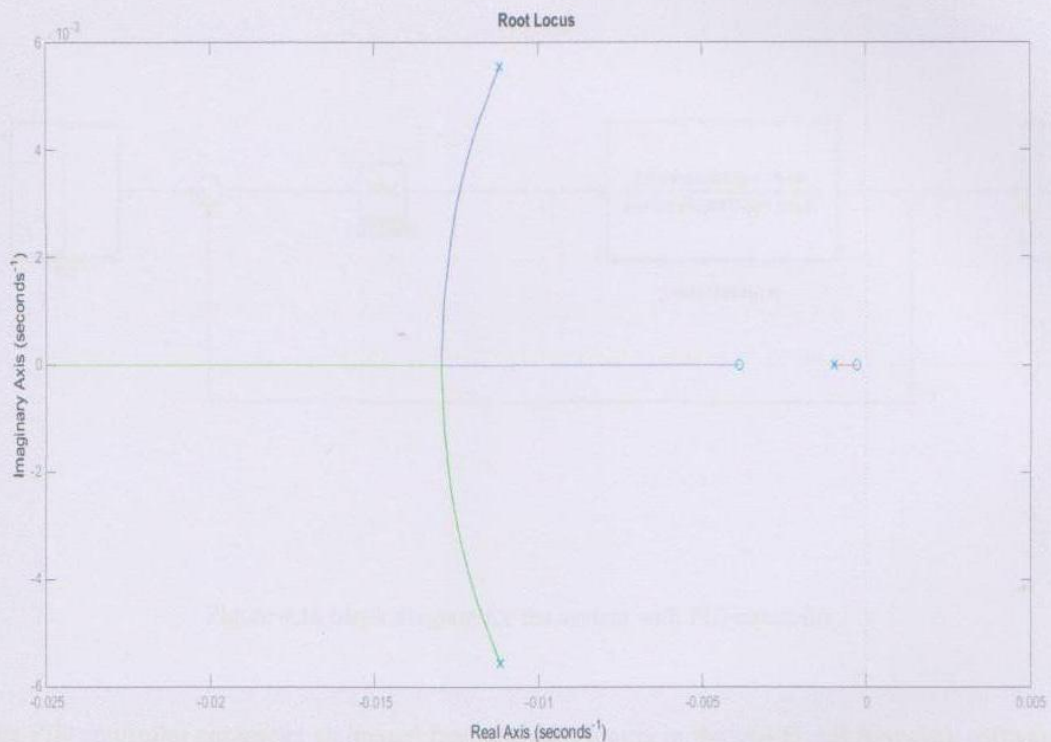

Figure 4.9 Root Locus

The system dynamics in the refrigeration system is not important like other factors. Settling time with the old controller is good. And from the Root Locus there is a pole near the origin. So the D controller can be removed. PI controller reduces the steady state error and the overshoot also the P controller can reduce the settling time. The decreasing in settling time is done by the changing the physical system. Compressor or the throttling device must be replaced.

The PID controller was designed using MATLAB control system toolbox and by using the PID auto tuning in the PID library in MATLAB software. Figure 4.10 show the block diagram of the plant and the block of the PID controller represented by the transfer function. The input to the system is step input and the output is shown in the scope.

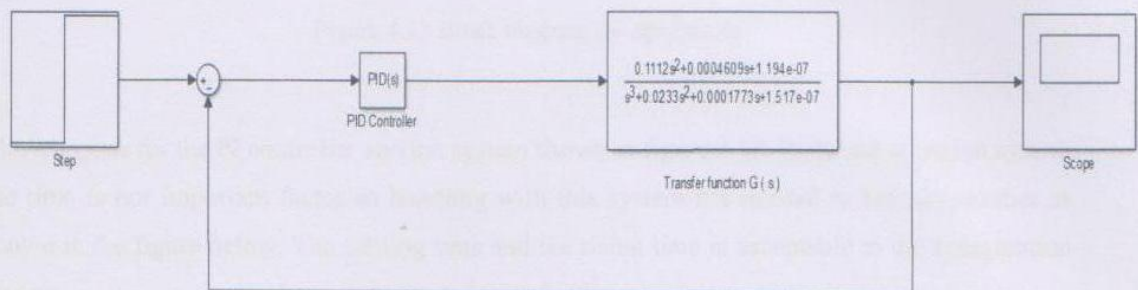

Figure 4.10 block diagram for the system with PID controller.

The PID controller parameter estimated from the auto tuning in the MATLAB Simulink software. The system was designed with minimum overshoot, settling time and steady state error. The auto tuning in MATLAB Simulink software showed that the D controller is not that important in this system. The block diagram can be changed with the new as shown in figure 4.11. the figure shows the transfer function with two or more blocks that represent the controller. the value of the P controller is equal to 0.0513110146157215. And the the value of the I controller is equal to 0.0052011572127598. for the D controller value is equal to zero.

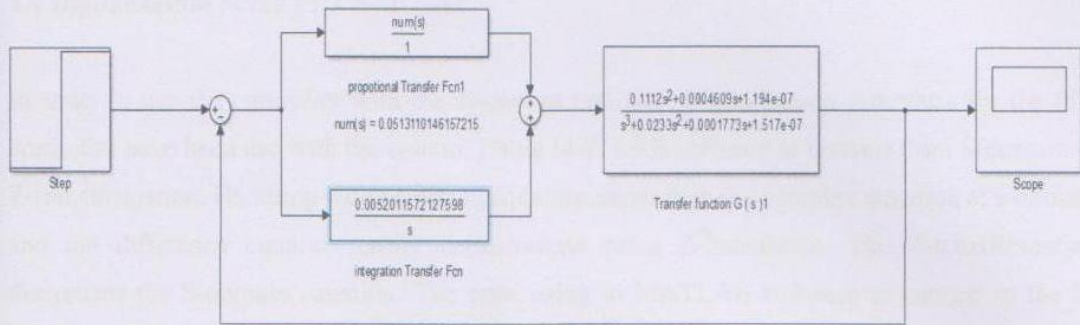

Figure 4.11 Block diagram for the system

The response for the PI controller and the system shown in figure 4.12. In the refrigeration system the time is not important factor so handling with this system it's normal to see big number as shown in the figure below. The settling time and the rising time is acceptable in the refrigeration system.

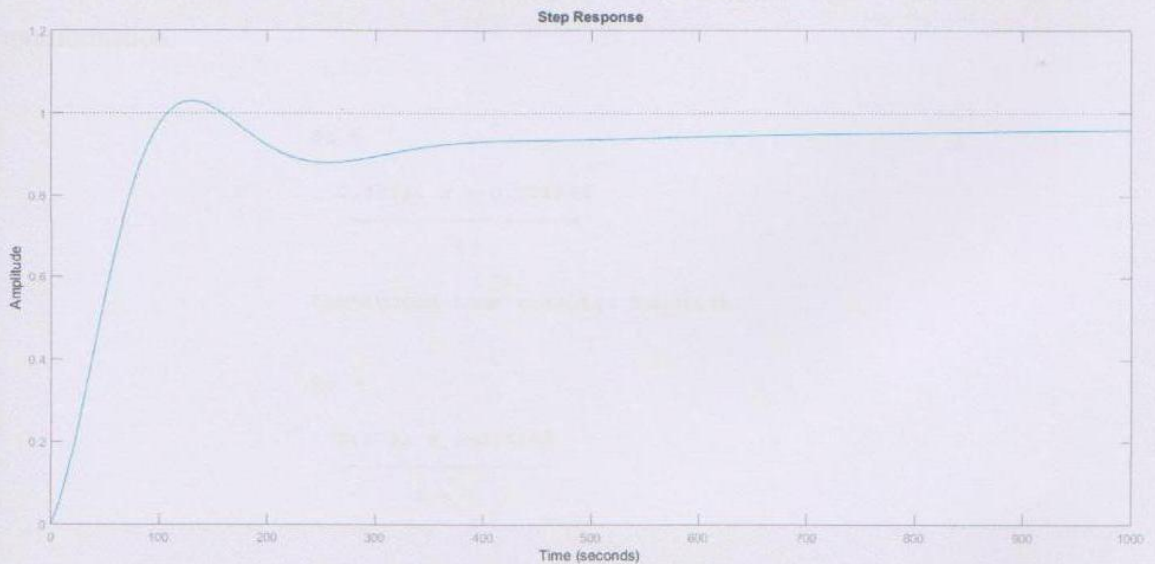

Figure 4.12 Step response.

4.4 Digitalization of the PID controller

In order to use the controller with the system at real live. Digitalization procedure for the PID controller have been use with the system. Using MATLAB software to convert from S-domain to Z-transformation. Handling with algebraic equation easier than the complex equation at s-domain and the difference equation easily caricaturized using Z-transforms. The Z-transformation discretizes the S-domain equation. The code using in MATLAB software to convert to the Z-transformation is:

```
% MATLAB code
% convert the controller from S-domain to the Z-domain
numGc=[0.051311 0.005201]
denGc=[1 0]
Gc=tf(numGc,denGc)
Gd=c2d(Gc,T,'tustin')
```

The result from this code is the Z- transformation of the controller. Figure 4.13 show the Z-transformation.

```
Gc =
      0.05131 s + 0.005201
      -----
              s
Continuous-time transfer function.

Gd =
      0.5731 z + 0.4705
      -----
              z - 1
Discrete-time transfer function.
```

Figure 4.13 Z-transformation.

Converting to Z-transformation to easily caricaturized the difference equation. The difference equation Equ 4.1. Where u is the current input, e is current error, u_p is the previous input and e_p is the previous error.

$$u = u_p + 0.5731 e + 0.4705 e_p \quad \text{Equ (4.1)}$$

4.5 Monitoring system

Monitoring is the most important part of the system to ensure that the system work in the right way. In the refrigeration system mentoring is done by the use of monitoring instrument such as site glass, manometer and thermistor. The ability of the new controller is to monitor the refrigeration system temperature and to recoup the temperature value. The main difference from old controller is that the temperature value is saved in the history of the Micro-controller. And the ability to reread the temperature value at any time.

In some refrigeration application such as refrigeration store the temperature history is important in order to ensure that the refrigerating system in the store work all the time. And that the temperature stay all the time constant. Figure 4.14 show the Raspberry-Pi which use as data logger for the temperature values and with Linux operating system for supporting the graphical user interface.

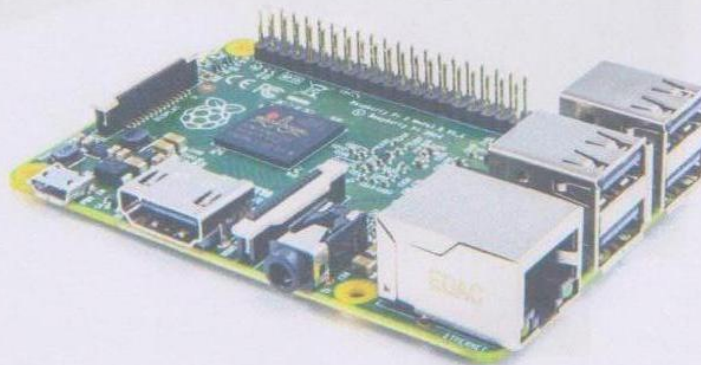

Figure 4.14 Raspberry-Pi.

With Raspberry-Pi and the embedded operating system and using Python programming language to program the graphical user interface. A 7-inch touch screen is used to interface and mentoring the refrigeration cycle shown in figure 4.15. The touch screen used to interact with the system and to reach the data storage in the Raspberry-Pi.

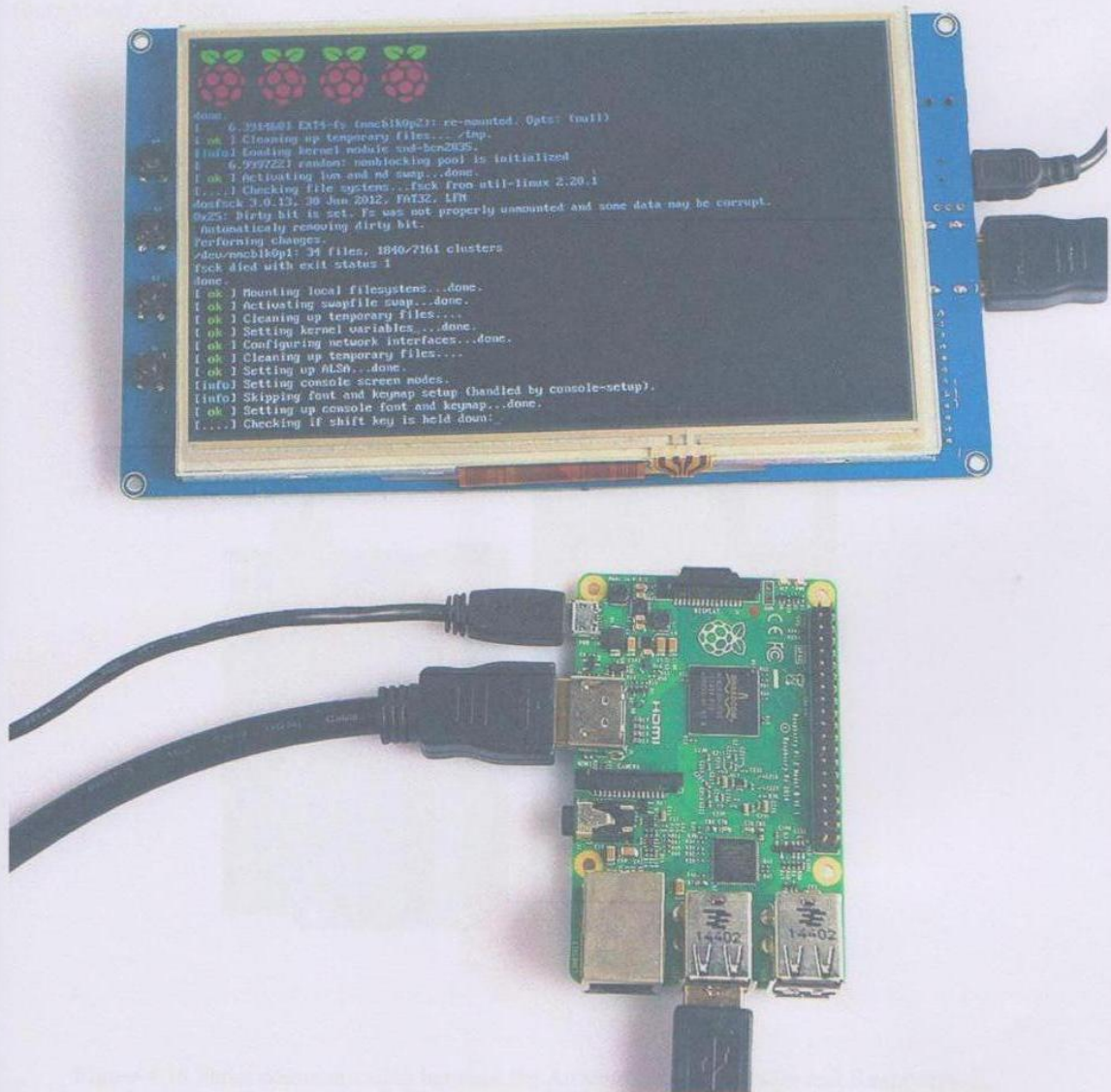

Figure 4.15 Touch screen

Serial communication between the Arduino Micro-controller and the Raspberry-Pi used to transfer the data. With this connection show in figure 4.16 the data was saved to the Raspberry-Pi memory. Serial communications are essential for every Micro-controller to communicate between Micro-controllers and another device. The Micro-controller sends these 1 and 0 (bits) which contain necessary information one by one, or Serially. These bits form together and turn into bytes (composed of 8 bits).

RaspPi-Arduino Serial Communication

01001000 01110101 00011101 11100010 10101011 01010100

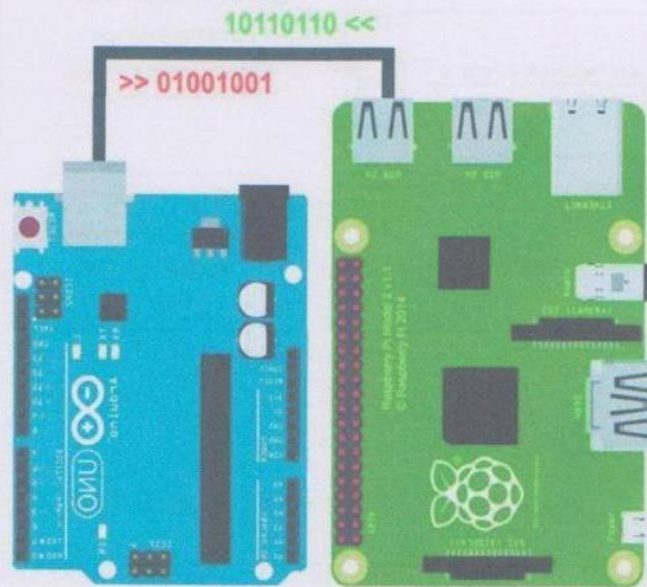

Figure 4.16 Serial communication between the Arduino Micro-controller and Raspberry-Pi.



4.6 Testing the system

In order to test the system. The transfer function and the PID controller have been tested and compared with the actual system. Figure 4.17 show the block diagram for for the system and controller. The surrounding temperature have been sit in the system. The temperature in the first time of the starting is assumed to be the surrounding temperature. The system has to cool down the temperature until rich the desired value of temperature.

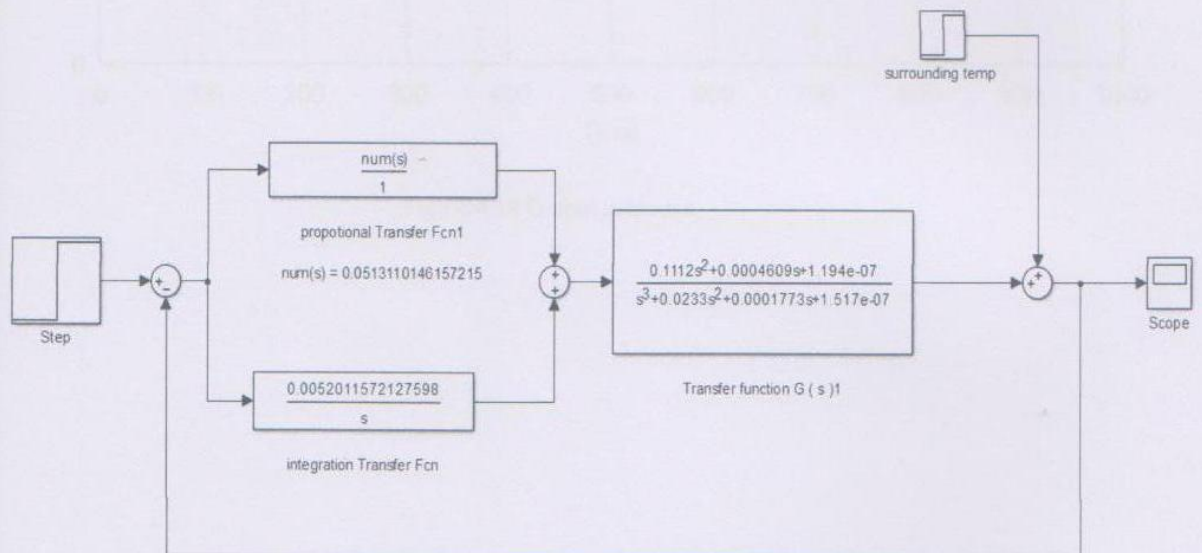

Figure 4.17 the block diagram for the system with the surrounding temperature.

The output response of the system is shown in figure 4.18. The surrounding temperature have been sit to the same vale of the surrounding temperature at the room. That's to compare between the actual system and the simulation. The result is approximately the same.

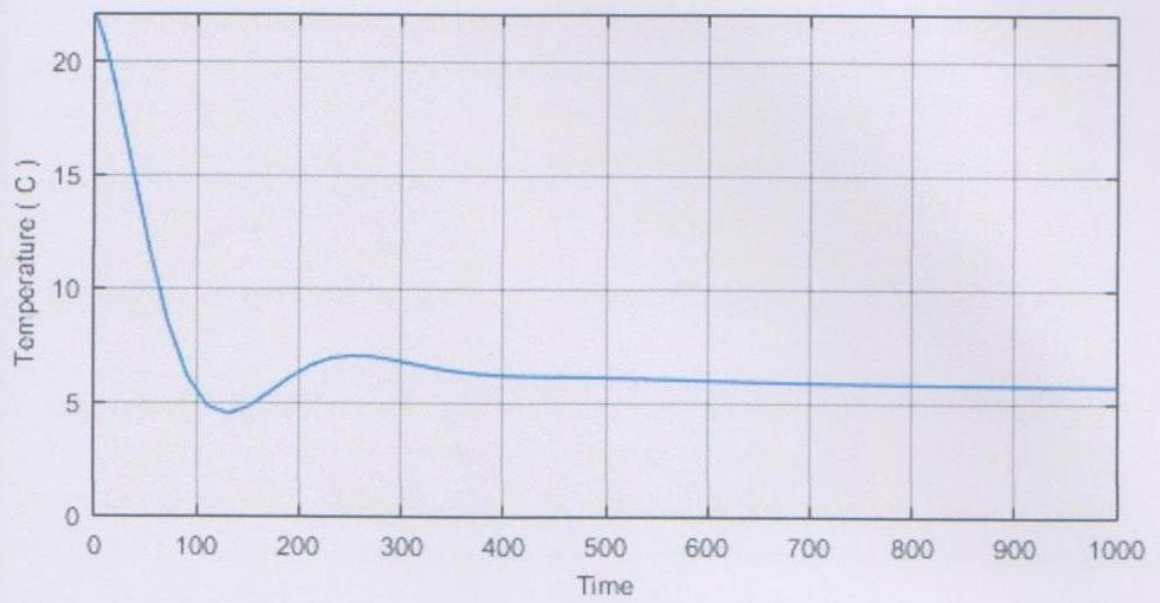

Figure 4.18 Output response.

3.1 Future perspectives

The main objective of this paper is to provide a comprehensive overview of the current state of the art in the field of [topic]. The paper is organized as follows: Section 2 discusses the background and motivation for this work. Section 3 presents the proposed method and its implementation. Section 4 shows the experimental results and compares them with the state-of-the-art. Section 5 concludes the paper and discusses future work.

In the future, we plan to extend our work by [topic]. We will also investigate the possibility of [topic]. We believe that our work will contribute to the understanding of [topic] and provide a useful reference for researchers in this field.

Chapter five

Results and future work

Figure 5.1: Results of the proposed method compared to the state-of-the-art.

5.1 Power consumption

The main concentration in this project is on the power consumption of the refrigeration cycle. The issue of power consumption and coefficient of performance for the refrigeration systems, considered as the main concern of most researchers. Company and researcher start working to on the refrigeration system by developing new idea to reduce the loss and increase the coefficient of performance.

In this project the power consumption was reduced, by reducing the electrical loss and by maintaining the inner temperature of the refrigerating space constant. Two experiments have been done on the system to check the power consumption in each case. The first experiment has been done in the system with the old conventional ON/OFF controller.

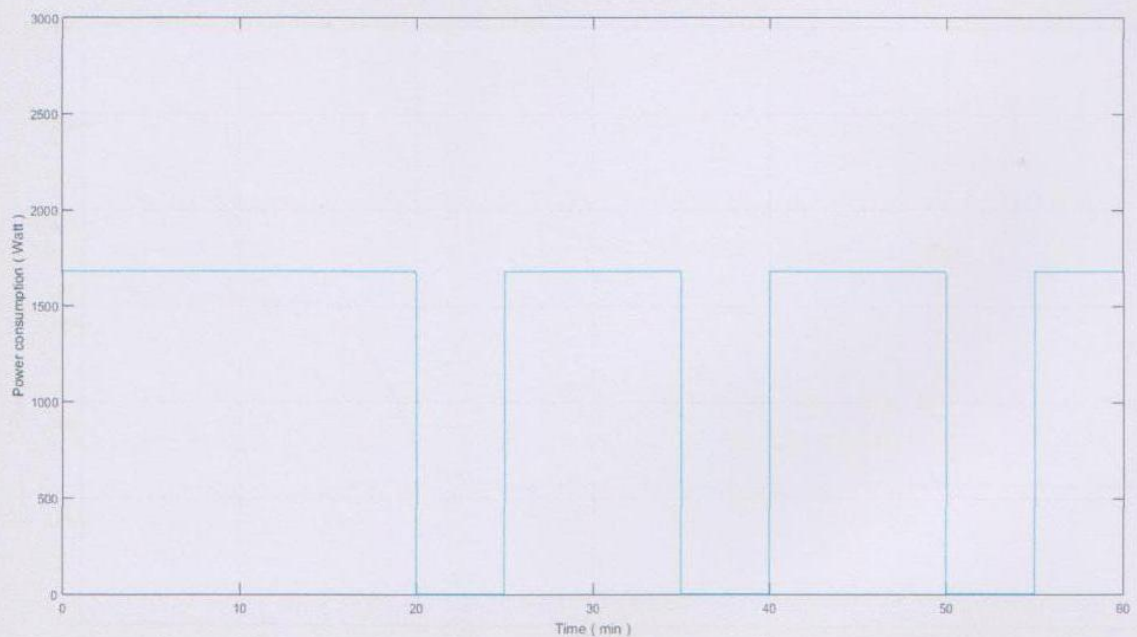

Figure 5.1 Power response with the old conventional ON/OFF controller.

Figure 5.1 shows the power consumption with the time when the old conventional ON/OFF controller was used. The power reached to the maximum value when the system is ON. Then the power decreased to the minimum value when the system is OFF. The high power consumption in the starting time is for a very small period so with this the starting high power consumption will not appear in the diagram below.

Figure 5.2 shows the power consumption with the time when the old conventional PID controller use. The power consumption starts from the high level of the power consumption which is similar to the power at the old conventional ON/OFF controller. Then the power start to decreases until it reaches the steady state power consumption. Then the change would be small.

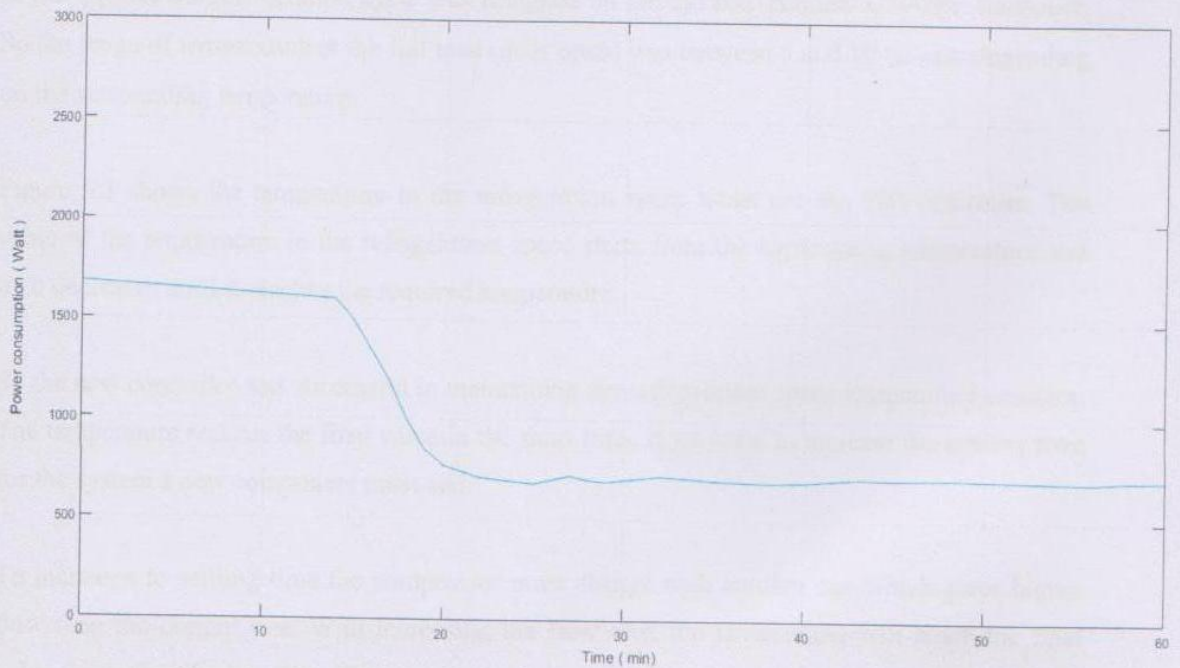

Figure 5.2 Power response with the new PID controller.

Using the Trapezoidal method to find the area under each curve in figure 5.1 / 2 which represent total power consumption. when the old conventional ON/OFF controller is used the total power consumption is 1260 Watt. But when the old conventional PID controller use the total power consumption is 971.6 Watt. The saving in power was around 22.89 % of the total power consumption.

5.2 Temperature consistency

Another major factor in this project is the temperature. The inside temperature of the refrigeration space deepened on the refrigeration load and the design of the refrigeration space. In this project the refrigeration cycle was designed on the old conventional ON/OFF controller. So the range of temperature at the full load (door open) was between 5 and 10 °C also depending on the surrounding temperature.

Figure 5.3 shows the temperature in the refrigeration space when use the PID controller. The value of the temperature in the refrigeration space starts from the surrounding temperature and then decreases until it reaches the required temperature.

So the new controller was successful in maintaining the refrigeration space temperature constant. The temperature reaches the final value in the short time. If we want to increase the settling time for the system a new component must add.

To increases to settling time the compressor must change with another one which gives higher flow than the current one. With increasing the flow rate, the temperature will reach the final value faster than the low flow rate.

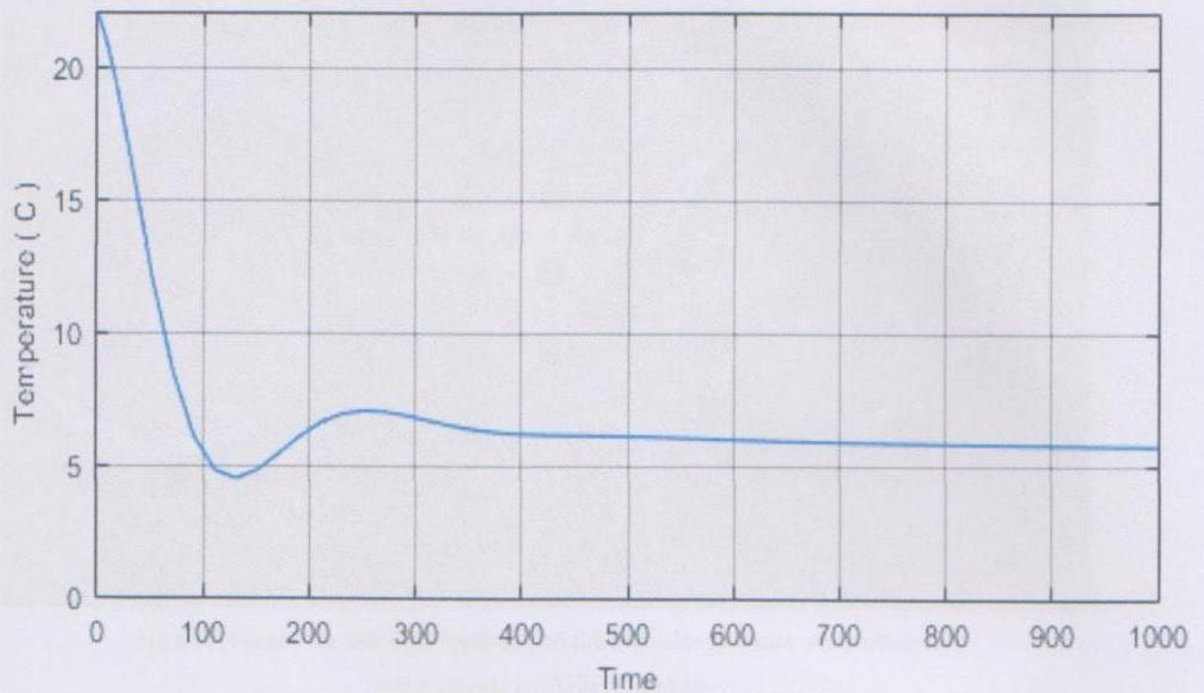

Figure 5.3 Output response.

5.3 High pressure side

In thermodynamics the energy need to raise the pressure from the high pressure to higher pressure is minimum than the energy need to raise the pressure from the low pressure to higher pressure. This is the thermodynamics explanation for the power consumption decrement with the new controller. Figure 5.4 shows the low side pressure and the high side pressure when using the conventional ON/OFF controller. Figure 5.5 shows the low side pressure and the high side pressure when using the PID controller. In the both cases the high side pressure of the refrigeration system is the same but the low side pressure when using the PID controller is higher than the low side pressure see figure 3.6 and figure 3.13. The result when the PID controller is used the power consumption is lower than the conventional ON/OFF controller.

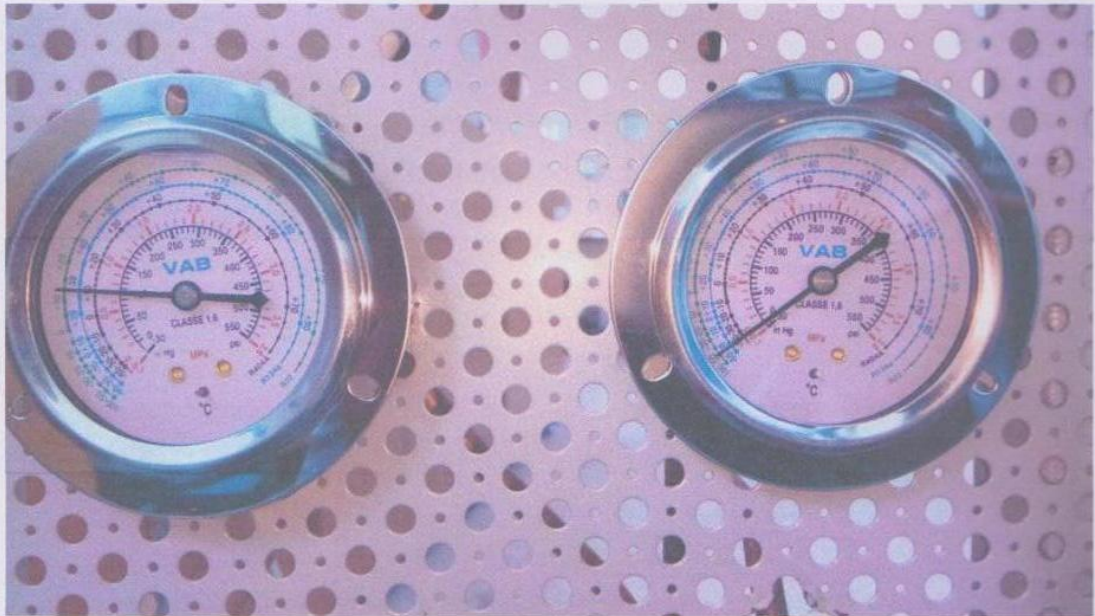

Figure 5.4 show the low side pressure and the high side pressure when using the conventional ON/OFF controller.

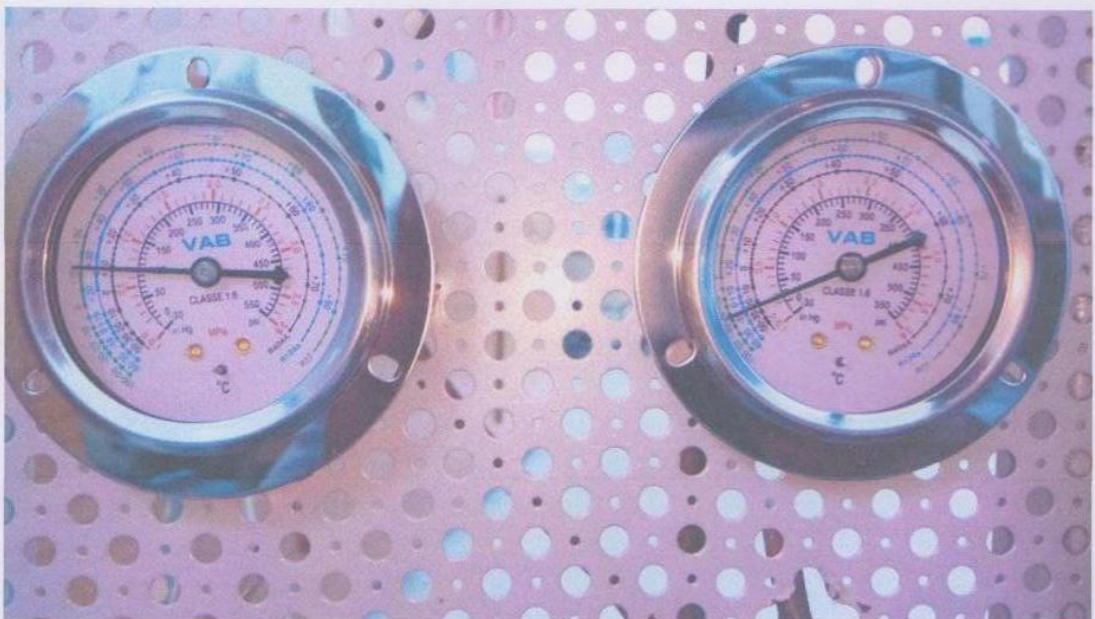

Figure 5.5 show the low side pressure and the high side pressure when using the PID controller.

5.4 Future work

In this section suggestion that may improve the current suggested controller is presented. This is some aspects that need farther investigation:

- 1- Implement the suggested controller on different types of refrigeration cycles, to test the performance of the controller on different topologies.
- 2- Remote control and monitor. The suggested system with current component has the ability to be modified in order to be controlled and monitored remotely.
- 3- Exploring the possibility of decreasing the settling time by changing the compressor and expansion device.

References

- [1] EKREN, Orhan; SAHIN, Savas; ISLER, Yalcin. *Operation of compressor and electronic expansion valve via different controllers*. INTECH Open Access Publisher, 2012.
- [2] ELLIOT, R. Neal; NADEL, Steven. *Realizing Energy Efficiency Opportunities in Industrial Fan and Pump Systems*.
- [3] RASHID, Muhammad H. *Power electronics handbook: devices, circuits and applications*. Academic press, 2010.
- [4] DOSSAT ROY, J. *Principles of refrigeration*. 1961.
- [5] BIRD, John. *Engineering mathematics*. Routledge, 2003.
- [6] RASHID, Muhammad H. *Power electronics: circuits, devices, and applications*. Pearson Education India, 2009.
- [7] Attia, Abdel-Hamid, Sohair F. Rezeka, and Ahmed M. Saleh. "Fuzzy logic control of air-conditioning system in residential buildings." *Alexandria Engineering Journal* 54.3 (2015).
- [8] Couch, Leon W., Muralidhar Kulkarni, and U. Sripati Acharya. *Digital and analog communication systems*. Vol. 6. Prentice Hall, 1997.
- [9] Keesman, Karel J. *System identification: an introduction*. Springer Science & Business Media, 2011.
- [10] Hendricks, Elbert, Ole Jannerup, and Paul Haase Sorensen. "Linear System Control." *DOI* 10 (2008): 978-3.
- [11] Franklin, Gene F., J. David Powell, and Michael L. Workman. *Digital control of dynamic systems*. Vol. 3. Menlo Park: Addison-wesley, 1998.